

 PBM VALVE SOLUTIONS

INDUSTRIAL VALVES

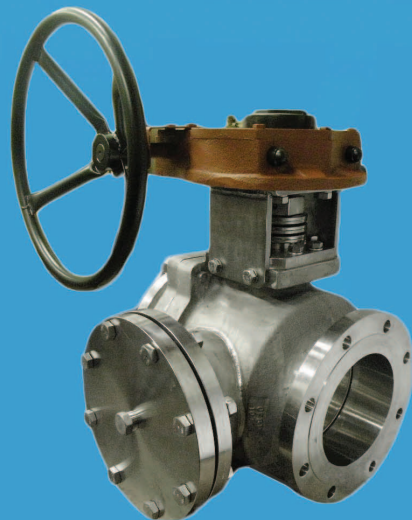
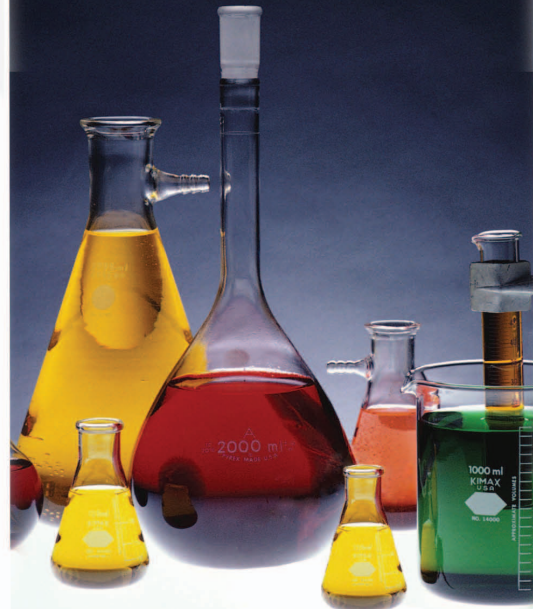

Adjust-O-Seal® feature

- PBM valves with adjustable sealing provide bidirectional upstream sealing.
- Valve body bolts can be tightened to compensate for normal seat wear without having to remove the valve from service.

Competitor's Design

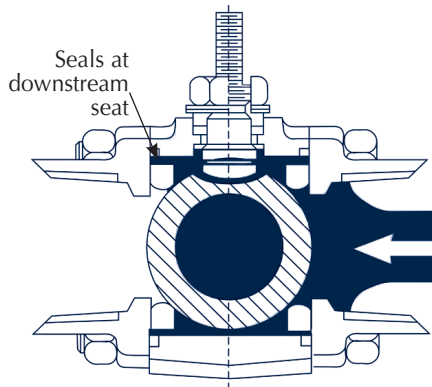

Line pressure pushes ball downstream in the ball-closed position, providing sealing at the downstream seat. There is no adjustment to compensate for seat wear.

PBM's Design

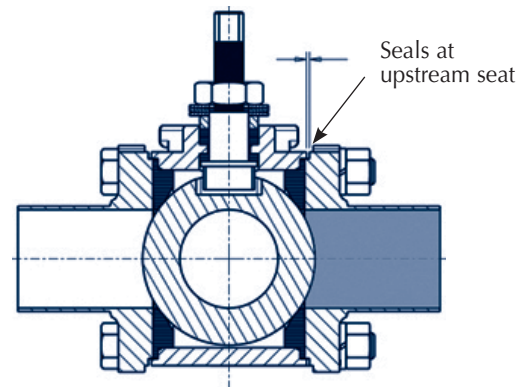

Valve body bolts compress valve seats against the ball, providing bidirectional sealing at the upstream seat. To compensate for seat wear, body bolts can be slightly tightened to recompress seats against ball.

PBM valves offer value over the life of the product with:

- Fewer process interruptions
- Longer life
- Clean/drain without process interruption
- Improved product yields





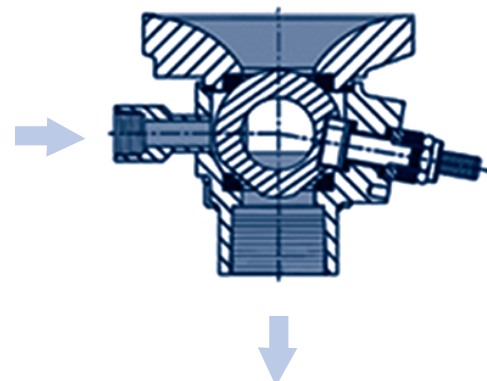





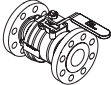

PBM also offers:

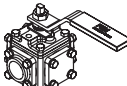
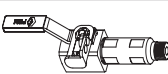
- On-time delivery
- Documentation
- Solutions to tough applications



This means on valves mounted vertically like PBM's angle stem flush tank valve, the valve seats on the upstream seat, thus allowing the body to be purged and drained without process interruption.

Table of Contents

ITEM	PAGE
Features	2
Ordering information	4-5
Materials of Construction	6
Seat & Seal materials	6
Allowable working pressures and temperature	7
Pressure and temperature charts; Cv factors	8
Torque values	9
Testing	10
Available options	10-11
Flow patterns	12
Metal Seats	13
Specifications	14-15
DIMENSIONAL INFORMATION, MANUAL & AUTOMATED	
 SP, SD Series, 2-Way Valves	16-17
 AN Series ANSI Valves	18-21
 FT, FD Series Flush Tank	22-23
 AF Series Angle Stem Flush Tank	24-25
 DP, DD Series 3-Way Diverter Port	26-27
 MP Series 3, 4, & 5-Way Multi-port	28-33
 Instrument Valves	34-35
 Bolted Instrument Valves	36-37
 Transmitter Isolation Valves,  Manifold Assemblies	38-39
 Flush/Bleed Rings,  Cryogenic Valves	40-41
 Automation and Controls	42-43
 Rep Locations	44

VALVE CONFIGURATION ORDERING INFORMATION ¹

Number(s) in parentheses indicate valve configuration part number position
PBM part numbers can have up to 20 alpha-numeric characters

Part Number Position	1	2	3	4	5	6	7	8	9	10	11	12	13	14	15	16	17	18	19	20
Part Number Code example	S	P	H	-	E	5	Q	-	G	-	-	-	3	4	A	-	R	X	X	X

INDUSTRIAL VALVES

PRODUCT (1-2)		MATERIAL ² (3-4)		SIZE (5)	SERIES (6)	END CONNECTION ³ (7-8)	SEAT & SEAL / FILLERS / O-RINGS ⁴ (9)		
AF Angle Stem	A- Aluminum	A 1/4	1 Series 1	B- Sch 40 butt weld	A RT	SEAT	FILLER	O-RING	
AN ANSI	B- 836 Bronze	B 3/8	3 Series 3	D- Sch 10 butt weld	B RT				
CN Cryogenic (ANSI)	C- Hastelloy® C-276	C 1/2	4 Series 4	J- Ext socket weld	C VT				
CP Cryogenic	C1 Hastelloy® B2	D 3/4	5 Series 5	K- Cam Lock	D VT				
DD Diverter (Steam)	D- Iron ⁶	E 1	6 Series 6	L- 150# Flange	F Metal				
DP Diverter Port	E- Carbon Steel ⁶	G 1-1/2	7 Series 7	M- 300# Flange	G TF				
FD Flush Tank (Steam)	H- 316 / 316L Stainless	H 2		N- 600# Flange	H HT				
FT Flush Tank	HC Alloy 20	J 2-1/2		O- Grooved	I HT				
MP Multi-Port	HL 316L Stainless	K 3		P- Male NPT	J TF				
SP Industrial 2-way	HF F316L Forged	L 4		Q- Female NPT	K UT				
SD SP (Steam)	H2 317L Stainless	M 6		Q1 BSPT	L UT				
	I- Inconel® 600	N 8		R- Sil-braze	M UT				
TI see page 12	M- Monel 400	P 10		S- Sil-braze 1 groove	N⁹ PK				
IM see page 14	N- 922 Bronze ⁵			T- Solder joint	O⁹ PK				
FR see page 14	P- AL6XN			U- Socket weld	P⁹ PK				
PV see page 15	R- 955 NiAl-Bronze			-Z No end fittings	Q⁹ CG				
	S- 953 Al- Bronze				R KY				
	T- Gr. 5 Titanium				S KY				
	T2 Gr. 2 Titanium				T VT				
	T7 Gr. 7 Titanium				U VT				
	W- Nickel 200				V RT				
	X- 958 NiAl-Bronze				W RT				
	Y- Hastelloy® C-22 ⁹				X PC				
	Z- 70/30 CuNi				Z TF				
	1- 90/10 CuNi				0 HT				
	5- Inconel® 625				1 HT				
	9- 954 Al-Bronze				2 TF				
	25 254SMO® 6Mo				3 UT				
	21 321 Stainless				4 UT				
	22 Duplex 2205				5 UT				
	76 Super Duplex 32750 / 32760				6⁹ PK				
	55 Ferralium 255				7 VT				
					8 RT				
					9 TF				

SEAT / SEAL / MATERIAL CODES

CG Carbon-Graphite
HT S-TEF®
KY Kynar®
PC PCTFE
PK PEEK®
RT RTFE
TF TFM™
UT UHMWPE
VT VTFE

Column 8 options

3 Non Adjust-O-Seal®
4 Reduced port
5 Non Adjust-O-Seal® & Reduced port
7 Flat-faced flanges
9 Bar-stock

O-RING MATERIAL CODES

EP EPR
KA Kalrez
VI Viton "A" 75 Durometer
VV PTFE Encapsulated Viton

SANITARY VALVES

PRODUCT (1-2)		MATERIAL ² (3-4)		SIZE (5)	SERIES (6)	END CONNECTION ³ (7-8)	SEAT & SEAL / FILLERS / O-RINGS ⁴ (9)		
AF Angle Stem	C- Hastelloy® C-276	A 1/4	1 Series 1	A- Acme Bevel	C VT	SEAT	FILLER	O-RING	
CS Clean Steam	H- 316 / 316L Stainless	B 3/8	3 Series 3	F- Ext tube butt weld	D VT				
CT Clean Steam Trap	HC Alloy 20	C 1/2	4 Series 4	G- Female CBI ⁷	G TF				
DI Diverter Port	HL 316L Stainless	D 3/4	5 Series 5	H- Male CBI ⁷	H HT				
DC Diverter (Steam)	HF F316L Forged	E 1	6 Series 6	I- Swagelok TS	I HT				
FI Flush Tank	H2 317L Stainless	G 1-1/2	8 Series 8	SM Compression clamp 1" BPE 09	J TF				
FC Flush Tank (Steam)	I- Inconel® 600	H 2	9 Series 9	W- clamp - tube	K UT				
MI Multi-Port	P- AL6XN	J 2-1/2		X- clamp - tube	L UT				
SI Sanitary 2-way	T- Gr. 5 Titanium	K 3		-Z No end fittings	M UT				
	T2 Gr. 2 Titanium	L 4			N PK				
	T7 Gr. 7 Titanium	M 6			O PK				
	Y- Hastelloy® C-22 ⁹				P PK				
	5- Inconel® 625				R KY				
	25 254SMO® 6Mo				S KY				
	21 321 Stainless				T VT				
	22 Duplex 2205				U VT				
	76 Super Duplex 32750 / 32760				X PC				
	55 Ferralium 255				Z TF				
					0 HT				
					1 HT				
					2 TF				
					3 UT				
					4 UT				
					5 UT				
					6 PK				
					7 VT				
					9 TF				

CURRENT PRODUCT SERIES

1 AF, PV, Bronze DP & MP, Ductile Iron MP
3 AF (Fire-safe API-607 Rev 4)
4 Stainless & Carbon Steel MP, Stainless MI (300# class maximum)
5 AN, DD, DP, FD, FT, Stainless MI ⁶ , Stainless MP ⁶ , SP, SD
6 AN, FI, SI, SP, FT (Fire-safe API-607 Rev 4)
6 CD, CN, CP (Fire-Safe API-607 (Rev. 6))
8 & 9 CS, CT, DC, DI, FC, FI, SI

STEAM vs. SEAT COMPATIBILITY

VTFE • ≤75psig at ≤320°F
TFM™ / RTFE • ≤150psig at ≤366°F
S-TEF® • ≤200psig at ≤388°F
PEEK • ≤320psig at ≤425°F

¹ - Not all options are available on all valve styles; consult PBM. ² - For valves with 2 different materials, use the 1st position for body material and the 2nd position for end fitting material. ³ - For valves with 2 different end connections, use both end codes - e.g. - FX = extended butt weld for tube by clamp. ⁴ - For standard seat/seal material by series, please see appropriate pricing page. PBM may substitute TFM™ for RTFE at our discretion without notice. TFM™ is a registered trademark of Dyneon™ - a 3M Company. Viton "A" is 75 Durometer. ⁵ - PBM reserves the right to use 922 Bronze in place of 836 Bronze without notification. ⁶ - All Carbon Steel and Ductile Iron valves will be coated internally and externally with Rust Veto 342, a rust inhibitor. Information on Rust Veto and/or an MSDS is available upon request. If Rust Veto is not acceptable, customer to advise specific coating required. Alternate coatings may impact price and delivery time. In addition, Carbon steel and Ductile Iron cast products are also painted (black in color) externally prior to Rust Veto coating. ⁷ - only available 1" through 8". ⁸ - 150# class maximum. ⁹ Requires 17-4PH stem

VALVE CONFIGURATION ORDERING INFORMATION ¹

Number(s) in parentheses indicate valve configuration part number position
PBM part numbers can have up to 20 alpha-numeric characters

Part Number Position	1	2	3	4	5	6	7	8	9	10	11	12	13	14	15	16	17	18	19	20
Part Number Code example	S	P	H	-	E	5	Q	-	G	-	-	-	3	4	A	-	R	X	X	X

INDUSTRIAL & SANITARY VALVE OPTIONS

FLOW PATTERN / TANK PAD / PURGE OPTIONS (10 & 11)	BALL / STEM OPTIONS (12)	OPERATOR OPTIONS (13 & 14)	POLISH OPTIONS (15)
<p>* DIVERTER PORT AND MULTI-PORT VALVES FOR DIVERTER AND MULTI-PORT VALVES, USE POSITION 10 & 11 TO INDICATE THE FLOW PATTERN - SEE PAGE 8 FOR FLOW PATTERNS</p> <p>FLUSH TANK OPTIONS (** POSITION 10 & 11 **)</p> <p>-- Standard flush tank weld pad 02 Less tank weld pad but with plastic or wood shipping pad</p> <p>05 w/1" bolt-on tank pad 06 w/1.5" bolt-on tank pad 07 w/2" bolt-on tank pad 08 w/3" bolt-on tank pad 09 w/4" bolt-on tank pad 10 w/6" bolt-on tank pad 11 w/8" bolt-on tank pad</p> <p>PURGE PORT OPTIONS (** POSITION 10 ONLY **)</p> <p>- No purge option(s) selected¹ A (1) 1/2" clamp on center 90° from stem B (1) 1/2" clamp on center opposite stem C (1) 1/2" clamp upstream 90° from stem D (1) 1/2" clamp downstream opposite stem E (2) 1/2" clamp (1) on center 90° from stem & (1) opposite stem F (2) 1/2" clamp (1) upstream 90° from stem & (1) downstream opposite stem G (1) 1/2" BWTE on center 90° from stem H (1) 1/2" BWTE on center opposite stem I (1) 1/2" BWTE upstream 90° from stem J (1) 1/2" BWTE downstream opposite stem K (2) 1/2" BWTE on center (1) 90° from stem & (1) opposite stem L (2) 1/2" BWTE (1) upstream 90° from stem & (1) downstream opposite stem M (1) 1/4" FNPT on center 90° from stem N (1) 1/4" FNPT on center opposite stem O (1) 1/4" FNPT upstream 90° from stem P (1) 1/4" FNPT downstream opposite stem Q (2) 1/4" FNPT (1) on center 90° from stem & (1) opposite stem R (2) 1/4" FNPT (1) upstream 90° from stem & (1) downstream opposite stem</p> <p>BALL HOLE & FLAT OPTIONS (** POSITION 11 ONLY **)</p> <p>- No ball options selected position A Flats in closed downstream position B Flats in closed upstream position C Flats in open upstream position D Flats in open downstream position E Flats in open upstream & downstream position F Holes in closed downstream position G Holes in closed upstream position H Holes in open upstream position I Holes in open downstream position J Holes in open upstream & downstream position K Ball with vent hole (downstream) V Standard width slotted ball W 30° V-ball X 45° V-ball Y 60° V-ball 7 Self-flush ball with flats closed downstream 8 Self-flushing ball 9 Ball with vent hole (upstream)</p>	<p>- Standard (316 / 316L ball & stem) F Internal / external grounding G 17-4PH stem I Monel ball J 932 Bronze ball K Monel stem & followers L Monel ball, stem & followers M Aluminum ball N 922 Bronze ball O Hastelloy C-276 ball P C-276 ball, stem & followers Q 922 Bronze ball w/Monel stem R Monel stem, followers & bolting S Monel ball, stem, followers & bolting T 922 Bronze ball, Monel stem & followers, Sil-braze bolting & CuSi fasteners U 922 Bronze ball w/Monel stem & followers V 12" extended stem/body bonnet (cryo only) 1 Chrome carbide (ball & seat coating) 2 Tungsten carbide (ball & seat coating)</p> <p>24vac 24vac 24vac 24vac 24vac 24vac PBM, Asco & Westlock combo</p> <p>55 DA80 psig actr & GP Sol 56 DA80 psig actr & GP LS & Sol</p> <p>57 DA80 psig actr & XP Sol 58 DA80 psig actr & XP LS & Sol</p> <p>59 DA60 psig actr & GP Sol 60 DA60 psig actr & GP LS & Sol</p> <p>61 DA60 psig actr & XP Sol 62 DA60 psig actr & XP LS & Sol</p> <p>63 SR80 psig actr & GP Sol 64 SR80 psig actr & GP LS & Sol</p> <p>65 SR80 psig actr & XP Sol 66 SR80 psig actr & XP LS & Sol</p> <p>67 SR60 psig actr & GP Sol 68 SR60 psig actr & GP LS & Sol</p> <p>69 SR60 psig actr & XP Sol 70 SR60 psig actr & XP LS & Sol</p>	<p>-- w/handle 00 Stainless locking oval handle 02 w/o handle, w/stem actr prep 03 w/handle, w/stem actr prep 04 Locking lever handle 05 w/stainless oval handwheel 07 w/45° handle 08 w/gear operator 09 w/T-handle 10 w/manual spring return handle 11 w/fusible link SR handle (165°F) 12 w/vane actr for 80psig 13 w/N4 electric actuator 14 w/XP electric actuator 15 w/square operating nut 17¹ w/4" ext lockable oval handwheel 18¹ w/4" ext lockable lever handle 17² w/2" ext lockable lever handle 72² w/2" ext lockable oval handwheel</p> <p>110vac 110vac 110vac 110vac 110vac PBM, Asco & Westlock combo</p> <p>20 DA80 psig actr 21 DA80 psig actr & GP LS 22 DA80 psig actr & GP Sol 23 DA80 psig actr & GP LS & Sol 24 DA80 psig actr & XP LS 25 DA80 psig actr & XP Sol 26 DA80 psig actr & XP LS & Sol 27 DA60 psig actr 28 DA60 psig actr & GP LS 29 DA60 psig actr & GP Sol 30 DA60 psig actr & GP LS & Sol 31 DA60 psig actr & XP LS 32 DA60 psig actr & XP Sol 33 DA60 psig actr & XP LS & Sol 34 SR80 psig actr 35 SR80 psig actr & GP LS 36 SR80 psig actr & GP Sol 37 SR80 psig actr & GP LS & Sol 38 SR80 psig actr & XP LS 39 SR80 psig actr & XP Sol 40 SR80 psig actr & XP LS & Sol 41 SR60 psig actr 42 SR60 psig actr & GP LS 43 SR60 psig actr & GP Sol 44 SR60 psig actr & GP LS & Sol 45 SR60 psig actr & XP LS 46 SR60 psig actr & XP Sol 47 SR60 psig actr & XP LS & Sol 51 DA80 psig actr & position indicator 52 DA60 psig actr & position indicator 53 SR80 psig actr & position indicator 54 SR60 psig actr & position indicator</p> <p>PBM, Asco & Topworx combo - 110vac</p> <p>73 DA80 psig actr & XP LS 74 DA80 psig actr, XP LS+GP Sol 75 DA80 psig actr, XP LS+XP Sol 76 DA60 psig actr & XP LS 77 DA60 psig actr & XP LS+GP Sol 78 DA60 psig actr & XP LS+XP Sol 79 SR80 psig actr & XP LS 80 SR80 psig actr, XP LS+GP Sol 81 SR80 psig actr, XP LS+XP Sol 82 SR60 psig actr & XP LS 83 SR60 psig actr & XP LS+GP Sol 84 SR60 psig actr & XP LS+XP Sol 85 DA80 psig actr & XP Prox 86 DA80 actr, XP Prox+XP Sol 87 DA60 psig actr & XP Prox 88 DA60 actr, XP Prox+XP Sol 89 SR80 psig actr & XP Prox 90 SR80 actr, XP Prox+XP Sol 91 SR60 psig actr & XP Prox 92 SR60 actr, XP Prox+XP Sol</p>	<p>- No polish A 20Ra ID B 32Ra OD C 20Ra ID / 32Ra OD D 15Ra ID E 10Ra ID F 20Ra ID after EP G 15Ra ID after EP H 10Ra ID after EP I 5Ra ID K 5Ra ID / 32Ra OD L 20Ra ID / 32Ra OD / EP M EP ID N 10Ra ID / 32Ra OD O 15Ra ID / 32Ra OD / EP Q 15Ra ID / 32Ra OD S 10Ra ID / 32Ra OD / EP</p> <p>LOX & BOLTING OPTIONS (16)</p> <p>- No option(s) required L LOX cleaning per PBM procedure M LOX & CRN bolting Z CRN bolting</p> <p>SPECIAL ENGINEERING # (17-20)</p> <p>*Special engineering number columns – consult PBM</p> <p>EXAMPLE: RXXX suffix at end of standard PBM part number</p> <p>RXXX = 2015 SXXX = 2016 TXXX = 2017 UXXX = 2018 VXXX = 2019 WXXX = 2020 XXXX = 2021 YXXX = 2022 ZXXX = 2023</p>

Polish Notes

- On ID polished valves, the body, ball, seat retainer (if applicable) and end fittings are polished
- On ID/OD polished valves, the body, ball, seat retainer (if applicable), and end fittings are polished
- On ID+EP polished valves, the body, ball, seat retainer (if applicable), end fittings are polished. Stem is EP²

Automation Notes

- ¹ Sanitary Series 1,3 AF 2 1/2" through 4" Series 8 & 9, Series 6
- ² Sanitary Series 8 & 9 only through 2"

Abbreviation Index

- GP = General Purpose
XP = Explosion Proof
LS = Limit Switch
Sol = Solenoid - N/C
DA = Double Acting
SR = Spring Return

Materials

Stainless Steel

316 S/S complies with ASTM A 351-CF8M or A479, S31600

316L S/S complies with ASTM A 351-CF3M or A479, S31603

- Is exceptionally corrosion-resistant to acidic and basic environments and does not pit easily.
- Can be polished to a near-mirror finish for easy cleanability.
- Weld fittings have a carbon content of <.03% to facilitate welding.

Carbon Steel, A216-WCB

- This versatile material handles mildly corrosive media.

Bronze, Alloy 922

- Excellent resistance to sea water environments and good steam resistance. Also, suitable for sub-zero temperature applications.

Hastelloy® C-276

- Very good corrosion in reducing and mildly oxidizing environments. Very good resistance to localized attack and very good resistance to stress corrosion cracking. Alloy CW-12MW in cast form.

Others

- Additional materials are available, including Alloy 20, Bronze, Duplex Stainless Steels, Hastelloys, Titanium, and Inconel®.

Seat and Seal Materials

Designation	Description	Color	Purpose
TFM™	Chemically Modified PTFE PBM Standard for Series 4, 5 6, & 7	White	Suitable for applications under 400°F. This chemically modified PTFE material is PBM's standard seat and seal material. It combines the ruggedness of a filled PTFE with the low coefficient of friction of virgin PTFE. TFM™ also has much improved porosity control and deformation under load when compared to PTFE grades. FDA and USP Class VI compliant. Meets bubbletight seat leakage.
RTFE	Glass Reinforced PTFE	Slightly Off White	Suitable for applications under 400°F. Used in a variety of applications. Bubbletight leakage.
VTFE	Virgin PTFE	White	Suitable for applications under 350°F. A low stem torque material ideal for sanitary use. FDA and USP Class VI compliant. Meets bubbletight seat leakage.
S-TEF®	Stainless Steel Reinforced PTFE	Charcoal Gray	Suitable for applications under 450°F. A suitable material for higher pressure/temperature applications. Higher stem torque than virgin grades and TFM™. USP Class VI compliant. Meets bubbletight seat leakage.
CARBON	Carbon/Graphite	Black	Suitable for applications under 750°F (400°C). A hard material impervious to high temperatures. It is used for heat transfer fluid applications and other high temperature applications. Meets Class V seat leakage.
UHMWPE	Ultra High Molecular Weight Polyethylene	Off White	Suitable for applications under 200°F. An extremely wear resistant material having a wear rate about 1/10th that of PTFE. FDA compliant and is used in high cycle applications where possible. Meets bubbletight seat leakage.
PEEK®	Poly ether ether ketone	Putty	Suitable for applications under 500°F. PEEK® is a rugged, high strength material having fairly high stem torque. PBM's PEEK® is 10 weight percent PTFE to reduce the hardness of virgin PEEK®. FDA compliant and meets Class V seat leakage.
KYNAR®	Polyvinylidene Fluoride	Slightly Transparent White	Suitable for applications under 250°F. Kynar® has been used successfully in abrasive service and is suitable for radiation environments where gamma levels accumulate to 1,000 megarads. FDA and USP Class VI compliant. Meets bubbletight seat leakage.

NOTES:

1. PTFE is Polytetrafluorethylene.
2. Seat and seal materials may be mixed in a valve in order to provide media-compatibility and the appropriate torque, temperature and pressure ratings.
3. Temperature ratings above based on 0 psi. See Pressure & Temperature charts on page 8.

Allowable Working Pressures and Temperatures

Valve Style/ Series	Material	Size (inches)	Non-Flanged					
			-20 to 100°F	-28.9 to 37.8°C	300°F	148.9°C	450°F	232.2°C
			psig	barg	psig	barg	psig	barg
SP, SD, DP, DD FT, FD Series 5	316 SS/316L	1-1/2" (DN40) and smaller	900	62.1	770	53.1	680	46.9
	316 SS/316L	2" and larger	720	49.6	620	42.7	540	37.2
	C-276	All	600	41.4	520	35.9	450	31.0
	Carbon Stl.	1-1/2" (DN40) and smaller	900	62.1	770	53.1	680	46.9
	Carbon Stl.	2" (DN50) and larger	740	51.0	655	45.2	620	42.7
SP, SD Series 5	922 Bronze	All	600	41.4	600	41.4	580	40.0
SP, FT, Series 6	316 SS/316L	3" (DN80) and smaller	720	49.6	620	42.7	540	37.2
	Carbon Stl.	3" (DN80) and smaller	740	51.0	655	45.2	620	42.7
CN	316 SS/316L	All	See Flanged Table at Right.					
AN, All Series	C-276	All						
	Carbon Steel	All						
	Bronze	All						
CP, CD Series 6	316 SS/316L	All	720	49.6	620	42.7	540	37.2
MP Series 1	836/922 Bronze	1-1/2" (DN40 and smaller)	400	27.6	385	26.5	360	24.8
	836/922 Bronze	2" (DN50)	350	24.1	340	23.4	315	21.7
	836/922 Bronze	3" (DN80)	300	20.7	290	20.0	270	18.6
	836/922 Bronze	4" (DN100)	See Flanged Table at Right					
	Ductile Iron	1-1/2" (DN40)	550	37.9	440	30.3	340	23.4
	Ductile Iron	2" (DN50)	500	34.5	400	27.6	310	21.4
	Ductile Iron	3" (DN80)	450	31.0	360	24.8	280	19.3
	Ductile Iron	4" (DN100)	See Flanged Table at Right					
MP, Series 4	316 SS/316L	3/4" (DN20) and smaller	900	62.1	770	53.1	680	46.9
	316 SS/316L	1" (DN 25) thru 4" (DN100)	720	49.6	620	42.7	540	37.2
	316 SS/316L	6" (DN150)	275	19.0	205	14.1	195	13.4
	C-276	3/4" (DN20) and smaller	900	62.1	770	53.1	680	46.9
	C-276	1" (DN25) thru 4" (DN100)	720	49.6	620	42.7	540	37.2
	C-276.	6" (DN150)	275	19.0	205	14.1	195	13.4
	Carbon Stl.	3/4" (DN20) and smaller	900	62.1	770	53.1	680	46.9
	Carbon Stl.	1" (DN25) thru 4" (DN100)	740	51.0	655	45.2	620	42.7
	Carbon Stl.	6" (DN150)	300	20.7	250	17.2	220	15.2
	Carbon Stl.	All	275	19.0	205	14.1	195	13.4
MP, Series 5	C-276	All	230	15.9	200	13.8	180	12.4
	Carbon Stl.	All	285	19.7	230	15.9	185	12.8
	Carbon Stl.	All	285	19.7	230	15.9	185	12.8
AF Series 1	316 SS/316L	1-1/2" (DN40) and smaller	900	62.1	770	53.1	680	46.9
	316 SS/316L	2" (DN50)	550	37.9	540	37.2	525	36.2
	316 SS/316L	3" (DN80)	625	43.1	610	42.1	600	41.4
	316 SS/316L	4" (DN100)	550	37.9	540	37.2	525	36.2
	316 SS/316L	6" (DN150)	375	25.9	365	25.2	360	24.8
	C-276	1-1/2" (DN40) and smaller	600	41.4	520	35.9	475	32.8
	C-276	2" (DN50), 4" (DN100)	550	37.9	540	37.2	525	36.2
	C-276	3" (DN80)	600	41.4	520	35.9	475	32.8
	C-276	4" (DN100)	550	37.9	540	37.2	525	36.2
	C-276	6" (DN150)	375	25.9	320	22.1	280	19.3
AF Series 3	316 SS/316L	1-1/2" (DN40) and smaller	720	49.6	620	42.7	540	37.2
	316 SS/316L	2" (DN50), 4" (DN100)	550	37.9	540	37.2	525	36.2
	316 SS/316L	3" (DN80)	625	43.1	610	42.1	600	41.4
	316 SS/316L	4" (DN100)	550	37.9	540	37.2	525	36.2
	316 SS/316L	6" (DN150)	375	25.9	365	25.2	360	24.8
TIV Series 5, 6	316 SS/316L	All	See Flanged Table at Right					
	C-276	All						
	Carbon Stl.	All						

Valid for all flanged valves:

ANSI 150# FLANGE						
Valve Material	-20° to 100° F psig	-28.9° to 37.8° C barg	300° F psig	150° C barg	450° F psig	232° C barg
836 Bronze	225	15.5	180	12.4	135	9.3
922 Bronze	225	15.5	195	13.4	160	11.0
955 Bronze	225	15.5	195	13.4	160	11.0
C-276	230	15.9	200	13.8	180	12.4
316/316L S/S	275	19.0	215	14.8	180	12.4
Carbon Steel.	285	19.7	230	15.9	185	12.8
ANSI 300# FLANGE						
Valve Material	-20° to 100° F psig	-28.9° to 37.8° C barg	300° F psig	150° C barg	450° F psig	232° C barg
C-276	600	41.4	520	35.9	475	32.8
316/316L S/S	720	49.6	560	38.6	495	34.1
Carbon Steel	740	51.0	655	45.2	620	42.7



Valves 1-1/2-Inch and Smaller

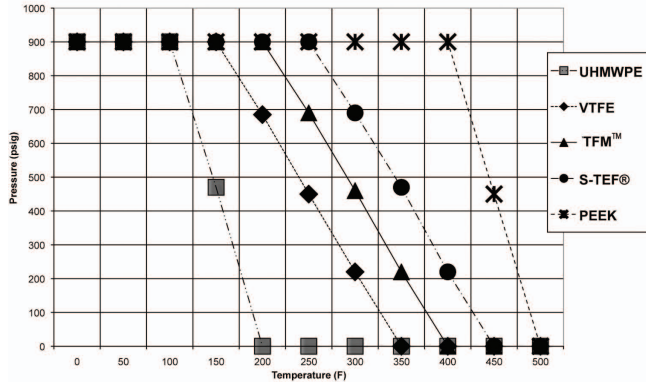

2-Inch to 3-Inch

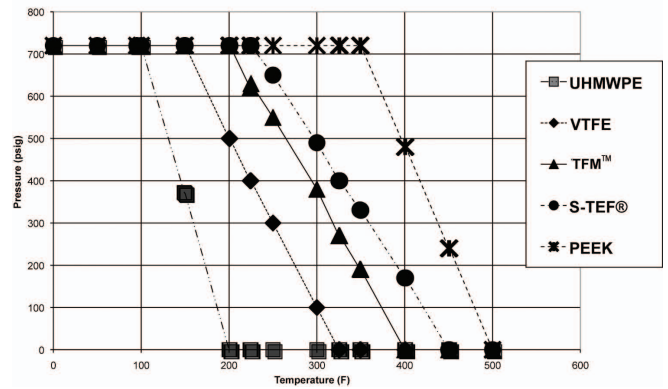

4 and 6-Inch

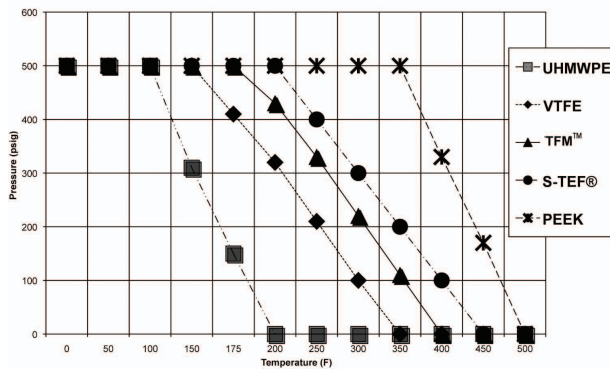

Seat & Seal Temperature and Pressure Charts

Cv Values (gpm)

VALVE SIZE	2-WAY			FLUSH TANK		DIVERTER PORT						
	SP	CP	AN, CN	AF	FT	DP SERIES 5 S/S		DP SERIES 1 BRONZE				
	SERIES 5	SERIES 6	SERIES 1/5	SERIES 1	SERIES 5	L-PORT	T-PORT	L-PORT	T-PORT			
							STRAIGHT	BRANCH		STRAIGHT	BRANCH	
1/4"	5*											
3/8"	10*											
1/2"	12	12	13		14	6.6	7.4	5.2	12	14	8.7	
3/4"	42*	42*	52		42	17	20	13	21	25	16	
1"	73	73*	80	65	70	33	39	24	33	39	24	
1-1/2"	170	170*	190	143	190	79	93	58	79	93	58	
2"	360	360*	400	280	370	149	180	110	149	180	110	
2-1/2"	650				600							
3"	935	935	1,100	700	900	350	415	250	290	345	210	
4"	1,900	1,900	2,400	880	1,650	640	770	465	460	540	340	
6"	4,800		5,600	1,500	3,900	1,550	1,860	1,110	1,050	1,220	790	
8"			10,700	7,400								
10"			17,400									

150# Flanged and Butt Weld, unless indicated otherwise noted (gpm at 1 psi d/p)

VALVE SIZE	MULTI-PORT											
	MP SERIES 5			MP SERIES 4				MP SERIES 1				
	L-PORT	T-PORT		LL-PORT	L-PORT	T-PORT		LL-PORT	L-PORT	T-PORT		LL-PORT
	STRAIGHT	BRANCH			STRAIGHT	BRANCH			STRAIGHT	BRANCH		
1/2"	6.6*	6.6*	5.4*	6.0*	6.6	7.4	5.2	6.6	12	14	8.7	6.6
3/4"	16*	16*	12*	14*	17	20	13	16	17	20	13	16
1"	33	33	21	30	33	39	24	27	33	39	24	27
1-1/4"					32	36	23	26	32	37	23	26
1-1/2"	80	80	49	72	79	93	58	73	79	93	58	73
2"	147	147	89	126	149	180	110	128	149	180	110	128
3"	351	351	212	295	350	415	250	300	200	250	140	180
4"	613	613	368	443	640	770	465	530	365	450	260	340
6"					1,550	1,860	1,110		1,550	1,860	1,110	

*Q (FNPT) ends

Stem Torque

Valve Style/ Series	Valve Size (in.)	As built Torque		Minimum Actuator Sizing vs. Differential Pressure across Seats																															
				0 psig		0 barg		100 psig		6.9 barg		200 psig		13.8 barg		300 psig		20.7 barg		400 psig		27.6 barg		500 psig		34.5 barg		600 psig		41.4 barg		700 psig		48.3 barg	
				in.-lb.	N-m	in.-lb.	N-m	in.-lb.	N-m	in.-lb.	N-m	in.-lb.	N-m	in.-lb.	N-m	in.-lb.	N-m	in.-lb.	N-m	in.-lb.	N-m	in.-lb.	N-m	in.-lb.	N-m	in.-lb.	N-m	in.-lb.	N-m	in.-lb.	N-m	in.-lb.	N-m		
All Series 5 & 6 2-Way & 3-Way	1/2	32	3.6	64	7.2	64	7.2	64	7.2	64	7.2	64	7.2	64	7.2	64	7.2	64	7.2	64	7.2	64	7.2	64	7.2	64	7.2	64	7.2	64	7.2	64	7.2		
	3/4	40	4.5	80	9.0	80	9.0	80	9.0	80	9.0	80	9.0	80	9.0	96	10.8	112	10.8	128	12.7														
	1	58	6.6	116	13.1	116	13.1	116	13.1	150	16.9	185	20.9	220	24.9	trun.																			
	1-1/2	154	17.4	308	34.8	308	34.8	440	49.7	580	65.5	715	80.8	trun.	trun.																				
	2	182	20.6	364	41.1	364	41.1	635	71.7	910	102.8	1,180	133.3	trun.	trun.																				
	2-1/2	288	32.5	576	65.1	576	65.1	1,200	135.6	1,600	180.8	trun.																							
	3	430	48.6	860	97.2	860	97.2	1,560	176.3	trun.																									
4	787	88.9	1,570	177.4	2,650	299.4	trun.																												
6	1,920	217.0	3,840	433.9	7,100	802.3	Use trunnion above 75 psid.																												
AF Series 1 & 3	1	58	6.6	116	13.1	116	13.1	116	13.1	150	17.0	185	20.9	220	24.9	255	28.8	288	32.5																
	1-1/2	132	14.9	264	29.8	264	29.8	375	42.4	500	56.5	600	67.8	725	81.9	850	96.1	950	107.4																
	2	154	17.4	308	34.8	308	34.8	440	49.7	580	65.5	715	80.8	850	96.1																				
	3	336	38.0	675	76.3	675	76.3	1,400	158.2	1,900	214.7	2,400	271.2	2,900	327.7	3,400	384.2																		
	4	432	48.8	860	97.2	860	97.2	1,560	176.3	2,050	231.7	2,540	287.0	3,030	342.4																				
6	1056	119.3	2100	237.3	3950	446.4	Use trunnion above 75 psid.																												
MP Series 5	1/2	67	7.57	135	15.3	142	16.0	149	16.8	154	17.4																								
	3/4	80	9.04	160	18.1	167	18.9	174	19.7	182	20.6																								
	1	154	17.4	307	34.7	322	36.4	337	38.1	358	40.5																								
	1-1/2	313	35.4	627	70.9	670	75.7	759	85.8	843	95.3																								
	2	491	55.5	981	110.9	1,037	117.2	1,238	139.9	1,388	156.8																								
3	840	94.9	1,679	189.7	2,084	235.5	2,761	312.0	3,268	369.3																									
4	1539	173.9	3,077	349.7	4,114	464.9	5,580	630.5	6,679	754.7																									
MP Series 4	1/2, 3/4	77	8.7	144	16.3	144	16.3	144	16.3	144	16.3	144	16.3	144	16.3	144	16.3	144	16.3	144	16.3														
	1	192	21.7	385	43.5	385	43.5	385	43.5	385	43.5	385	43.5	385	43.5	385	43.5	440	49.7	trun.	trun.														
	1-1/2	384	43.4	770	87	770	87	770	87	940	106.2	trun.	trun.																						
	2	432	48.8	865	97.7	865	97.7	865	97.7	1,200	135.6	trun.	trun.																						
	3	864	97.6	1,730	195.5	1,730	195.5	trun.	trun.																										
	4	1,920	216.9	3,840	433.9	3,840	433.9	trun.	trun.																										
6	3,000	339.0	6,000	678.0	8,800	994.4																													
MP Series 1	1/2, 3/4	77	8.7	144	16.3	144	16.3	144	16.3	144	16.3	144	16.3																						
	1	192	21.7	385	43.5	385	43.5	385	43.5	385	43.5	385	43.5																						
	1-1/2	384	43.4	770	87	770	87	770	87	940	106.2	trun.	trun.																						
	2	432	48.8	865	97.7	865	97.7	865	97.7	1,200	135.6	trun.	trun.																						
	3	576	65.1	1,150	129.9	1,150	129.9	1,620	183	2,100	135.6																								
4	864	97.6	1,700	192.1	3,000	339	trun.	trun.																											

- Notes:
- For valves with UHMWPE and RTFE seats, multiply the above values by 1.25
 - For valves which have S-TEF® or Kynar® seats multiply the above values by 1.56.
 - For valves with PEEK® seats multiply the above values by 1.7.
 - Where trunnion is indicated, PBM recommends trunnion mounting the ball to avoid excessive seat loads and stem torques.
 - For AF Series 1 and 3 stem torques, refer to PBM Sanitary Brochure, LT-34.
 - CP torque valves assume service at -320°F.
 - For Series 5 SD, FD, DD valves ins steam service and having RTFE seats, multiply minimum TFM/VTFE actuator torques by 1.56.

CP Series 6 These are actuals, not sizing.		As Built Torque		Cryo As Built																																						
		in.-lb.	N-m	in.-lb.	N-m																																					
	1/2	95	11	95	11	95	11	95	11	95	11	95	11	95	11	95	11	95	11	95	11	101	11	110	12																	
	3/4	95	11	95	11	95	11	95	11	95	11	95	11	95	11	95	11	95	11	95	11	101	11	110	12																	
	1	145	16	160	18	160	18	160	18	160	18	160	18	170	19	193	22	215	24	238	27																					
	1-1/2	420	47	420	47	420	47	420	47	420	47	420	47	477	54	544	61	611	69	677	76																					
	2	540	61	840	95	840	95	840	95	840	95	840	95	866	98	1013	114	1162	131	1310	148	1458	165																			
	3	1020	115	1320	149	1320	149	1320	149	1542	174	1984	224	2425	274	2866	324	3307	374	3749	424																					
	4	Consult PBM Engineering.																																								

Testing

- Vacuum Testing
- Cycle Testing
- Shock and Vibration
- Seismic
- Hydrostatic
- Material Test Reports
 - Physical testing
 - Chemical testing

Options

- Trunnion
- Manual Spring Return Handles
- LOX (Cleaned for Oxygen Service)
- Body Cavity Fillers
- Steam Seats (Encapsulated)
- Purge Ports (SIP/CIP)
- Fire Rated, API 607
- Dribble Control Units
- High Alloys
- Fabflex[®] Manifolds
- Self Cleaning Flushable Ball
- USCG Category A
- ABS Type Approval
- Mechanical & Electro-Polishing
- Direct Mount Actuation
- Positioners
- Fieldbus, AS-i, DeviceNet
- Ball Flats or Purge Holes
- Locking & Ext. Locking Handles
- Internal & External Grounding
- Cylindrical Radius Weld Pads
- V-Balls for Flow Control

Steam Valves

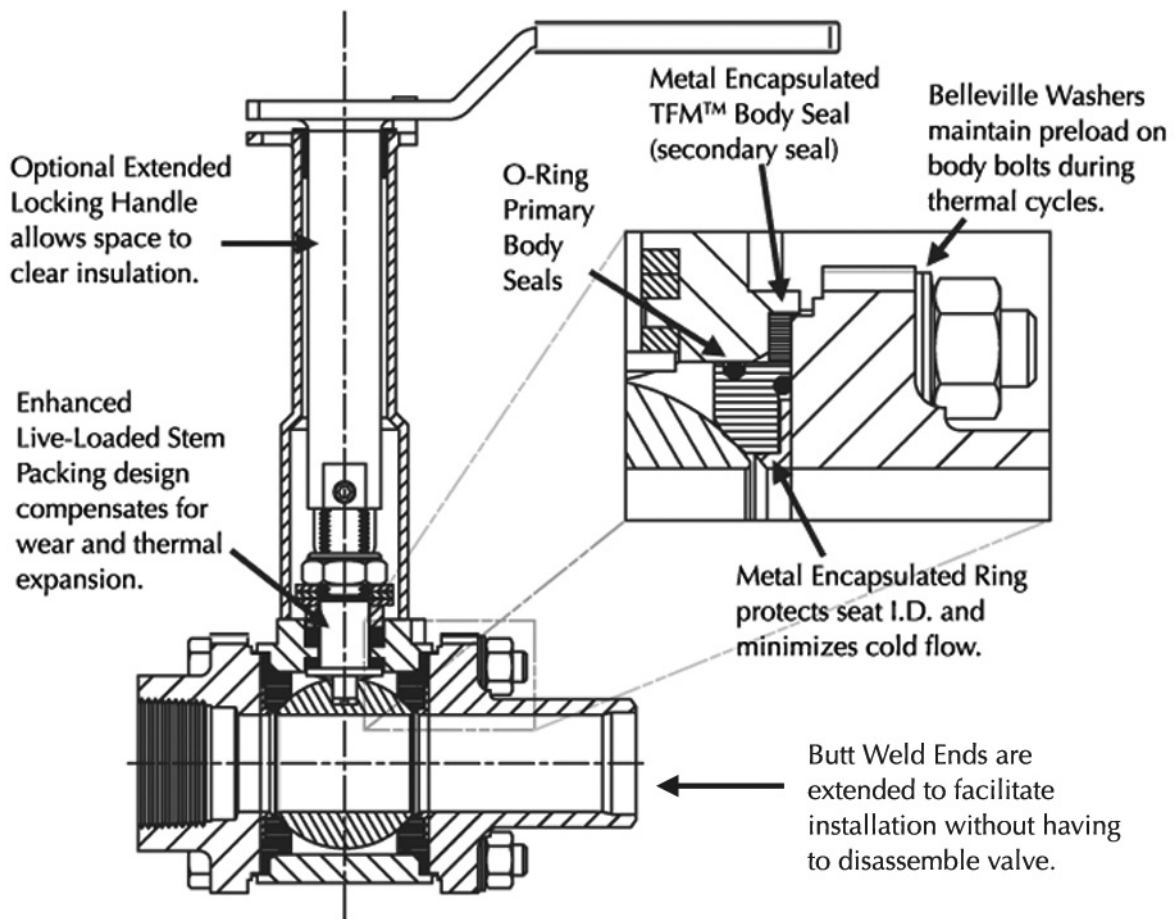

Options

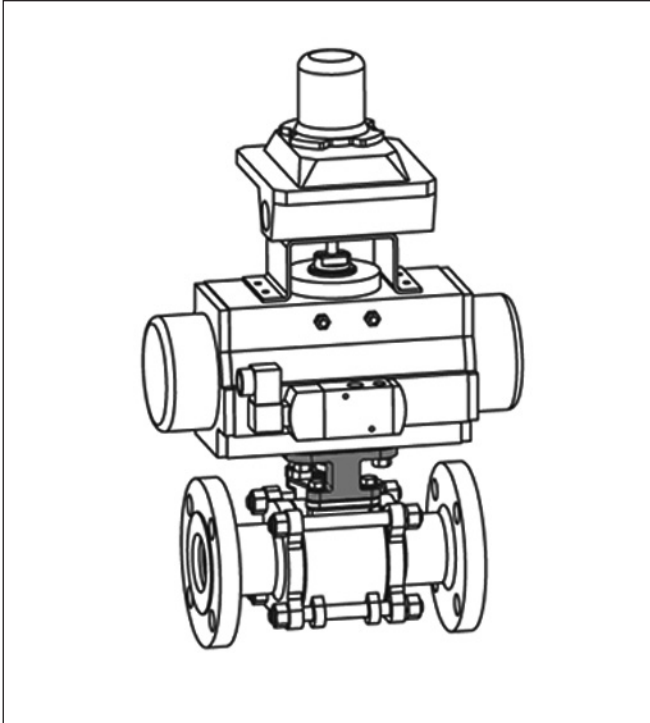

Direct Mount Actuation

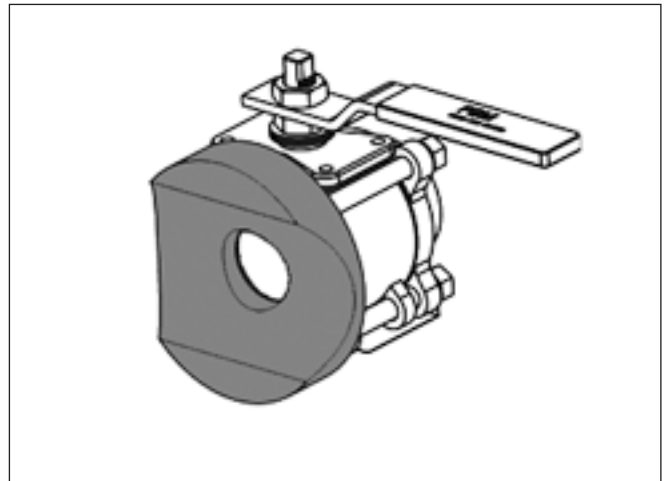

Cylindrical Radius Pad

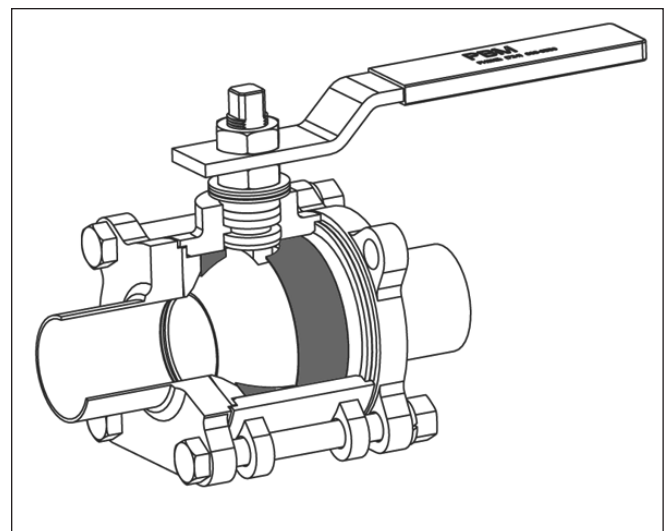

Cavity Fillers

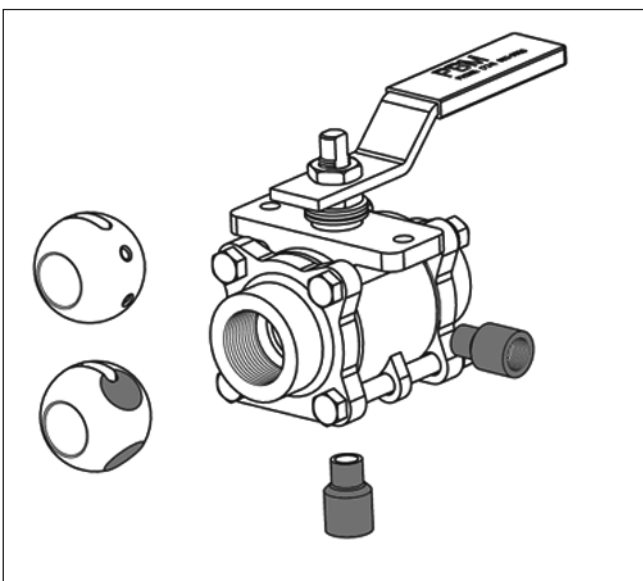

Purge Ports, Milled Flats and Purge Holes

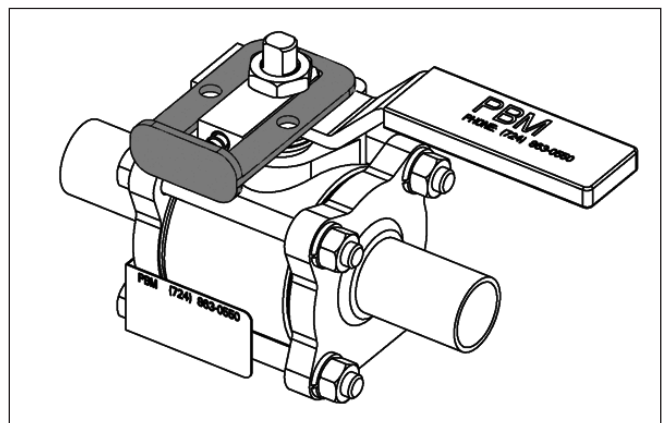

Locking Handle



Industrial Ball Valves

PBM FLOW PATTERNS

Code (#) Port Style	DP • 3-way • SIDE ENTRY				DP • 3-way • BOTTOM ENTRY				
	03 T-90°	04 T-90°	06 T-180°	10 L-90°	14 L-360°	15 L-180°	16 T-90°	17 TT-180°	18 LL-90°
Position A									
Position B									
Position C									
Position D									

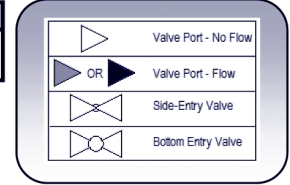

Code (#) Port Style	MP • 3-way • SIDE ENTRY												
	01 T-90°	02 T-90°	03 T-90°	04 T-90°	05 T-180°	06 T-180°	07 T-180°	08 T-180°	09 T-360°	10 L-90°	11 L-180°	12 L-180°	13 L-360°
Position A													
Position B													
Position C													
Position D													

Code (#) Port Style	MP • 3-way • BOTTOM ENTRY					
	14 L-360°	15 L-180°	16 T-90°	17 TT-180°	18 LL-90°	19 L-90°
Position A						
Position B						
Position C						
Position D						

The flow diagrams depicted are a birds-eye-view - as though you are looking down on the stem.

For more information on PBM's flow patterns, please see our Industrial, Sanitary Brochures or visit us on the web!

www.pbmvalve.com

Code (#) Port Style	MP • 4-way • BOTTOM ENTRY												
	20 LL-90°	21 LL-180°	22 LL-180°	23 LL-180°	24 LL-180°	25 LL-360°	26 L-360°	27 T-90°	28 TT-180°	29 TT-180°	30 TT-180°	31 TT-180°	32 TT-360°
Position A													
Position B													
Position C													
Position D													

Code (#) Port Style	MP • 4-way • BOTTOM ENTRY				MP • 4-way • SIDE ENTRY							
	33 TT-90°	34 TT-90°	35 TT-90°	36 TT-90°	37 LL-90°	38 L-180°	39 L-360°	40 T-180°	41 -90°	42 T-90°	43 T-90°	
Position A												
Position B												
Position C												
Position D												

Code (#) Port Style	MULTI-PORT • 5-way • BOTTOM ENTRY								52
	44 L-360°	45 LL-180°	46 T-90°	47 TT-90°	48 TT-90°	49 TT-180°	50 TT-360°	51 LL-360°	Y-120°
Position A									
Position B									
Position C									
Position D									

Metal Seats

PBM's Metal Seated Valve Applications include:

- STEAM SERVICE
- HIGH TEMPERATURE / PRESSURE
- ABRASION RESISTANCE
- MODULATING SERVICE



Design Features:

- 1/2" - 4" in Full Bore, CL150 and CL300 standard
- Design capability to manufacture larger sizes and higher pressure classes
- Temps up to 800°F/427°C
- Class V shut-off
- Live-loaded packing assures long maintenance-free operation
- PBM's metal seated valves are fundamentally firesafe
- Valves with weld end fittings can be welded without disassembly.
- Optional patented locking lever handle and complete line of automation and controls
- Complete repair services available - fast turn around on valve repair
- Short lead times on stocked ANSI valves sizes 1/2" through 2"
- SIL-3 capable per IEC 61508
- Extended handles and automation brackets available for higher temperature services.

Specially designed carbide and/or ceramic thermal spray coatings are a valve industry standard. All of the coatings are applied robotically, using the Accuraspray Plume Sensor System, to insure consistently high quality coatings.

CHROME CARBIDE	
TYPICAL COMPOSITION, WT%	
Nickel Chrome	20%
Chrome Carbide	Balance
COATING CHARACTERISTICS	
Bond Strength, PSI	>10,000/ 690 bar
Hardness	67
Porosity	2%
Max. Service Temperature	800°F/427°C

TUNGSTEN CARBIDE	
TYPICAL COMPOSITION, WT%	
Carbon	3.7%
Iron	0.5%
Nickel	10.0%
Tungsten Carbide	Balance
COATING CHARACTERISTICS	
Bond Strength, PSI	>10,000/ 690 bar
Hardness	65-58 RC
Porosity	<1%
Max. Service Temperature	800°F/427°C

Coating Options:

Chrome Carbide, 20% Nickel/Chrome

A hard coating that does not oxidize at high temperatures. Provides good abrasion, particle erosion cavitation and fretting resistance in high temperature environments. Good corrosion resistance and sliding properties.

Tungsten Carbide, 10% Nickel

A hard, dense coating to resist high abrasive conditions, as well as particle erosion and fretting while providing the corrosion resistance of nickel with minimal loss of heat resistance.

Coating Testing:

- Bond Strength Tensile Test
- Shear Strength Tensile Test
- Macro Hardness Rockwell Test
- Porosity Determination
- Bond Line Contamination
- Abrasion Wear Testing



Written Specifications

SP, SD SERIES 5

Two-Way, Full Port Ball Valve; Body, ball, stem, and end fitting material shall be 316/316L Stainless Steel, HASTELLOY® C-276, Carbon Steel, Bronze Alloy 922, or other. Valve shall be three-piece “swing-out” body design. Seats and seals shall be TFM™ - PTFE material and provide both upstream and downstream bubbletight seal and be adjustable for in-line wear. (For SD Series 5 Only - Seats shall be TFM™ - PTFE material with EPR O-ring energizer. Seats shall have 316/316L Stainless Steel encapsulation on ID, provide both upstream and downstream bubbletight seal, and be adjustable for in-line wear. Body seal shall be EPR O-rings with TFM™ - PTFE back up seal. Body bolts shall be live loaded with Belleville washers.) Stem packing shall be live loaded TFM™ - PTFE. For manual valves, handle shall be 300 series stainless steel with optional lever locking device. Body bolts, nuts, and Belleville washers shall be 18-8 stainless steel. Maximum working pressure to be 900 psig but is limited based on valve size, valve material, and end fitting type. Valves are full vacuum. Valves shall not require disassembly for butt welding. Valves shall be non-firesafe design unless otherwise specified. For fire rated valves to API 607 Edition 4, sizes 1/2” - 3”, designate Series 6 (see section “FIRE RATED”).

PBM Model Number “SP” or “SD”(Material)(Size)5(End Connection)(Seat & Seal, Cavity Filler, O-Ring Material)

SD Series 5: Two-way full port steam ball valve; Body, ball, stem, and end fitting material shall be 316 stainless steel, HASTELLOY® C-276, Carbon Steel, HASTELLOY® C-22®, bronze alloy 922, or other. Valve shall be three-piece “swing-out” body Seats shall be TFM™-PTFE with EPR O-ring energizer. Seats shall have stainless steel encapsulation on ID, provide both upstream and downstream bubbletight seal and be adjustable for in-line wear. Stem packing shall be live loaded white TFM™-PTFE. Body seal shall be EPR o-rings with white TFM™-PTFE back up seal. Optional 300 Series s/s 2” stem extension for 4” thick installation. Valves shall not require disassembly for butt welding.

Body bolts, nuts, and belleville washers shall be 18-8 stainless steel. Body bolts shall be live-loaded with belleville washers. Maximum working pressure to be 720 PSIG and full vacuum but is limited based on valve size, valve material, and end fitting type. Valves shall be a non-firesafe design. To add automation and controls, see section “Automation and Controls”.

PBM Model number SD(material)-(size)5(end connection)

FT, FD SERIES 5

FLUSH TANK BOTTOM BALL VALVE; BODY, BALL, STEM, AND END FITTING MATERIAL SHALL BE 316/316L STAINLESS STEEL, HASTELLOY® C-276, CARBON STEEL, BRONZE ALLOY 922, OR OTHER. WELD PAD SHALL BE 316L STAINLESS STEEL OR OTHER MATERIAL (SPECIFY). VALVE SHALL BE THREE-PIECE “SWING-OUT” BODY DESIGN. SEATS AND SEALS SHALL BE TFM™ - PTFE MATERIAL AND PROVIDE BOTH UPSTREAM AND DOWNSTREAM BUBBLETIGHT SEAL AND BE ADJUSTABLE FOR IN-LINE WEAR. (FOR FD SERIES 5 ONLY - SEATS SHALL BE TFM™ - PTFE MATERIAL WITH EPR O-RING ENERGIZER. SEATS SHALL HAVE 316/316L STAINLESS STEEL ENCAPSULATION ON ID, PROVIDE BOTH UPSTREAM AND DOWNSTREAM BUBBLETIGHT SEAL, AND BE ADJUSTABLE FOR IN-LINE WEAR. BODY SEAL SHALL BE EPR O-RINGS WITH TFM™ - PTFE BACK UP SEAL. BODY BOLTS SHALL BE LIVE LOADED WITH BELLEVILLE WASHERS.) STEM PACKING SHALL BE LIVE LOADED TFM™ - PTFE. FOR MANUAL VALVES, HANDLE SHALL BE 300 SERIES STAINLESS STEEL WITH OPTIONAL LEVER LOCKING DEVICE. BODY BOLTS, NUTS, AND BELLEVILLE WASHERS SHALL BE 18-8 STAINLESS STEEL. VALVES SHALL BE NON-FIRESAFE DESIGN UNLESS OTHERWISE SPECIFIED. FOR FIRE RATED VALVES TO API 607 EDITION 4, SIZES 1/2” - 3”, DESIGNATE SERIES 6 (SEE SECTION “FIRE RATED”).

TO ADD AUTOMATION AND CONTROLS, SEE SECTION “AUTOMATION AND CONTROLS”.

PBM MODEL NUMBER “FT” OR “FD”(MATERIAL)(SIZE)5(END CONNECTION)(SEAT & SEAL, CAVITY FILLER, O-RING MATERIAL)

AF SERIES 1

ANGLE STEM FLUSH TANK BOTTOM BALL VALVE; BODY, BALL, STEM, AND END FITTING MATERIAL SHALL BE 316/316L STAINLESS STEEL, HASTELLOY® C-276, CARBON STEEL, BRONZE ALLOY 922, OR OTHER. WELD PAD SHALL BE 316L STAINLESS STEEL OR OTHER MATERIAL (SPECIFY). VALVE SHALL BE TWO-PIECE DESIGN. SEATS AND SEALS SHALL BE RTFE MATERIAL AND PROVIDE BOTH UPSTREAM AND DOWNSTREAM BUBBLETIGHT SEAL AND BE ADJUSTABLE FOR IN-LINE WEAR. STEM PACKING SHALL BE LIVE LOADED RTFE. FOR MANUAL VALVES, HANDLE SHALL BE 300 SERIES STAINLESS STEEL WITH OPTIONAL LEVER LOCKING DEVICE. BODY BOLTS AND NUTS SHALL BE 18-8 STAINLESS STEEL. VALVES SHALL BE NON-FIRESAFE DESIGN UNLESS OTHERWISE SPECIFIED. FOR FIRE RATED VALVES TO API 607 EDITION 4, SIZES 1” - 6”, DESIGNATE SERIES 3 (SEE SECTION “FIRE RATED”). TO ADD AUTOMATION AND CONTROLS, SEE SECTION “AUTOMATION AND CONTROLS”.

PBM MODEL NUMBER AF(MATERIAL)(SIZE)1(END CONNECTION)(SEAT & SEAL, CAVITY FILLER, O-RING MATERIAL)

CP SERIES 6, 2-WAY FIRESAFE CRYOGENIC VALVE

UNI-DIRECTIONAL FLOW AND VENTED BALL; MATERIAL SHALL BE 316/316L STAINLESS STEEL OR OTHER MATERIAL (SPECIFY). SEATS AND SEALS SHALL BE TFM™, seat and stem packings shall be live-loaded. Valve shall be uni-directional with body markings for flow direction and upstream vent hole in ball. End connections available include female NPT, 150# ANSI RF flanged, extended butt weld for Sch 40 pipe and extended socket weld ends. Extended ends do not require valve to be disassembled for welding. For manual valves, handle shall be 300 series stainless steel. Maximum working pressure to be 720 psig CWP and temperatures from ambient to -320 degrees F (-200 degrees C). Valve shall be cleaned for oxygen service and shall meet or exceed leakage performance per MSS SP-134.

Optional automation (Pneumatic or electric), mechanical and electro-polishing surfaces, sizes 1/2-inch through 4-inch

PBM MODEL NUMBER CP(MATERIAL)(SIZE)(SERIES)(END CONNECTION)(SEAT & SEAL, CAVITY FILLER, O-RING MATERIAL)

DP, DD SERIES 5

THREE-WAY, DIVERTER PORT BALL VALVE; BODY, BALL, STEM, AND END FITTING MATERIAL SHALL BE 316/316L STAINLESS STEEL, HASTELLOY® C-276, OR OTHER. VALVE SHALL BE THREE-PIECE DESIGN. SEATS AND SEALS SHALL BE TFM™ - PTFE MATERIAL AND PROVIDE BOTH UPSTREAM AND DOWNSTREAM BUBBLETIGHT SEAL AND BE ADJUSTABLE FOR IN-LINE WEAR. (FOR DD SERIES 5 ONLY - SEATS SHALL BE TFM™ - PTFE MATERIAL WITH EPR O-RING ENERGIZER. SEATS SHALL HAVE 316/316L STAINLESS STEEL ENCAPSULATION ON ID, PROVIDE BOTH UPSTREAM AND DOWNSTREAM BUBBLETIGHT SEAL, AND BE ADJUSTABLE FOR IN-LINE WEAR. BODY SEAL SHALL BE EPR O-RINGS WITH TFM™ - PTFE BACK UP SEAL. BODY BOLTS SHALL BE LIVE LOADED WITH BELLEVILLE WASHERS.) STEM PACKING SHALL BE LIVE LOADED TFM™ - PTFE. FOR MANUAL VALVES, HANDLE SHALL BE 300 SERIES STAINLESS STEEL WITH

OPTIONAL LEVER LOCKING DEVICE. BODY BOLTS, NUTS, AND BELLEVILLE WASHERS SHALL BE 18-8 STAINLESS STEEL. MAXIMUM WORKING PRESSURE TO BE 900 PSIG BUT IS LIMITED BASED ON VALVE SIZE, VALVE MATERIAL, AND END FITTING TYPE. VALVES ARE FULL VACUUM. SPECIFY PBM FLOW PATTERN. TO ADD AUTOMATION AND CONTROLS, SEE SECTION "AUTOMATION AND CONTROLS".

PBM MODEL NUMBER "DP" OR "DD"(MATERIAL)(SIZE)5(END CONNECTION)(SEAT & SEAL, CAVITY FILLER, O-RING MATERIAL)(PBM FLOW PATTERN)

AN SERIES 1

TWO-WAY, ANSI FLANGED FULL PORT BALL VALVE; BODY, BALL, STEM, AND END FITTING MATERIAL SHALL BE 316/316L STAINLESS STEEL, HASTELLOY® C-276, CARBON STEEL, BRONZE, ALUMINUM BRONZE, OR OTHER. VALVE SHALL BE TWO-PIECE "SPLIT BODY" DESIGN. SEATS AND SEALS SHALL BE RTFE MATERIAL WITH VITON® OR EPR O-RING BODY SEAL. SEATS SHALL PROVIDE BOTH UPSTREAM AND DOWNSTREAM BUBBLETIGHT SEAL AND BE ADJUSTABLE FOR IN-LINE WEAR. STEM PACKING SHALL BE LIVE LOADED RTFE. END FITTINGS SHALL BE ANSI 150# FLANGED PER ANSI B16.5 AND FACE TO FACE DIMENSION SHALL CONFORM TO ASME B16.10 LONG PATTERN. FOR MANUAL VALVES, HANDLE SHALL BE 300 SERIES STAINLESS STEEL WITH OPTIONAL LEVER LOCKING DEVICE. BODY BOLTS AND NUTS SHALL BE 18-8 STAINLESS STEEL. MAXIMUM WORKING PRESSURE TO BE 285 PSIG BUT IS LIMITED BASED ON VALVE SIZE, VALVE MATERIAL, AND END FITTING TYPE. VALVES ARE FULL VACUUM. VALVES SHALL BE 100% TESTED PER ASME / ANSI B16.34. VALVES SHALL BE NON-FIRESAFE DESIGN UNLESS OTHERWISE SPECIFIED. FOR FIRE RATED VALVES TO API 607 EDITION 4, SIZES 1/2" - 6", DESIGNATE SERIES 3 OR SERIES 6 (SEE SECTION "FIRE RATED"). TO ADD AUTOMATION AND CONTROLS, SEE SECTION "AUTOMATION AND CONTROLS".

PBM MODEL NUMBER AN(MATERIAL)(SIZE)1(END CONNECTION)(SEAT & SEAL, CAVITY FILLER, O-RING MATERIAL)

AN SERIES 5

TWO-WAY, ANSI FLANGED FULL PORT BALL VALVE; BODY, BALL, STEM, AND END FITTING MATERIAL SHALL BE 316/316L STAINLESS STEEL OR CARBON STEEL. VALVE SHALL BE TWO-PIECE "SPLIT BODY" DESIGN. SEATS AND SEALS SHALL BE TFM™ - PTFE MATERIAL WITH VITON® OR EPR O-RING BODY SEAL. SEATS SHALL PROVIDE BOTH UPSTREAM AND DOWNSTREAM BUBBLETIGHT SEAL AND BE ADJUSTABLE FOR IN-LINE WEAR. STEM PACKING SHALL BE LIVE LOADED TFM™ - PTFE. END FITTINGS SHALL BE ANSI 150# FLANGED PER ANSI B16.5 AND FACE TO FACE DIMENSION SHALL CONFORM TO ASME B16.10 LONG PATTERN. FOR MANUAL VALVES, HANDLE SHALL BE 300 SERIES STAINLESS STEEL WITH OPTIONAL LEVER LOCKING DEVICE. BODY BOLTS AND NUTS SHALL BE 18-8 STAINLESS STEEL. MAXIMUM WORKING PRESSURE TO BE 740 PSIG BUT IS LIMITED BASED ON VALVE SIZE, VALVE MATERIAL, AND END FITTING TYPE. VALVES ARE FULL VACUUM. VALVES SHALL BE 100% TESTED PER ASME / ANSI B16.34. VALVES SHALL BE NON-FIRESAFE DESIGN UNLESS OTHERWISE SPECIFIED. FOR FIRE RATED VALVES TO API 607 EDITION 4, SIZES 1/2" - 4", DESIGNATE SERIES 6 (SEE SECTION "FIRE RATED"). TO ADD AUTOMATION AND CONTROLS, SEE SECTION "AUTOMATION AND CONTROLS".

PBM MODEL NUMBER AN(MATERIAL)(SIZE)5(END CONNECTION)(SEAT & SEAL, CAVITY FILLER, O-RING MATERIAL)

MP SERIES 1, 4 AND 5

THREE, FOUR, OR FIVE WAY MULTI-PORT BALL VALVE; BODY, BALL, STEM, AND END FITTING MATERIAL SHALL BE 316/316L STAINLESS STEEL, CARBON STEEL, HASTELLOY® C-276, OR OTHER (SERIES 1 ONLY - DUCTILE IRON AND BRONZE). VALVE SHALL HAVE 4 OR 5 TFM™ - PTFE (SERIES 1 ONLY - RTFE) SEATS AND SEALS AND PROVIDE BUBBLETIGHT SEAL AND BE ADJUSTABLE FOR IN-LINE WEAR. STEM PACKING SHALL BE LIVE LOADED TFM™ - PTFE (SERIES 1 ONLY - RTFE). FOR MANUAL VALVES, HANDLE SHALL BE 300 SERIES STAINLESS STEEL (SERIES 4 OR 5 - OPTIONAL LEVER LOCKING DEVICE). BODY BOLTS AND NUTS SHALL BE 18-8 STAINLESS STEEL. MAXIMUM WORKING PRESSURE TO BE 720 PSIG (SERIES 1 ONLY - 400 PSIG) BUT IS LIMITED BASED ON VALVE SIZE, VALVE MATERIAL, AND END FITTING TYPE. VALVES ARE FULL VACUUM. SPECIFY PBM FLOW PATTERN FOR 3, 4, OR 5-WAY VALVE. TO ADD AUTOMATION AND CONTROLS, SEE SECTION "AUTOMATION AND CONTROLS".

PBM MODEL NUMBER MP(MATERIAL)(SIZE)(SERIES)(END CONNECTION)(SEAT & SEAL, CAVITY FILLER, O-RING MATERIAL)(PBM FLOW PATTERN)

TI SERIES 5

TRANSMITTER ISOLATION BALL VALVE; BODY, BALL, STEM, AND END FITTING MATERIAL SHALL BE 316/316L STAINLESS STEEL, HASTELLOY®, TITANIUM, OR OTHERS WITH 1" OR 2-1/2" PORT DIAMETER. TANK SIDE FLANGE TO ACCOMMODATE BOTH STANDARD ANSI 3", 150# FLANGE DRILLING AND A 25 TO 27 DEGREE OFFSET FLANGE PATTERN. INSTRUMENT SIDE FLANGE SHALL BE DRILLED TO ACCOMMODATE A STANDARD ANSI 3", 150# FLANGE DRILLING. VALVE SHALL HAVE A 1/4 TURN MANUAL 300 SERIES STAINLESS STEEL HANDLE WITH LEVER LOCKING DEVICE. VALVE SHALL HAVE FOUR (4) 1/4" FNPT PURGE PORTS, EACH WITH A 1/4" MNPT PLUG MADE FROM THE SAME MATERIAL AS THE VALVE BODY. SEATS AND SEALS SHALL BE TFM™ - PTFE MATERIAL WITH VTFE O-RING.

PBM MODEL NUMBER TI(MATERIAL)(SIZE)5(END CONNECTION)(SEAT & SEAL, CAVITY FILLER, O-RING MATERIAL)

FIRE RATED (SERIES 3 AND SERIES 6)

TWO-WAY, INDUSTRIAL BALL VALVE; SP SERIES 6 AND FT SERIES 6, 1/2" - 3", AN SERIES 6, 1/2" - 4", AN SERIES 3 AND AF SERIES 3, 1" - 6". ADD TEXT: VALVE DESIGN SHALL BE TESTED AND COMPLY WITH CRITERIA SET FORTH IN API-607 EDITION 4. VALVE BODY BOLTS TO BE FULLY ENCAPSULATED. VALVE DESIGN IS NON-ADJUST-O-SEAL®. BODY SEALS SHALL BE GRAPHITE MATERIAL ISOLATED FROM PRODUCT STREAM UNDER NORMAL OPERATING CONDITIONS BY O-RING SEALS. UPON SUBLIMATION OF SEAT AND SEAL MATERIAL IN THE EVENT OF A FIRE CONDITION, A METAL BACK UP SEAT SHALL SEAL THE VALVE AT LEAKAGE RATES IN ACCORDANCE WITH API-607, EDITION 4. Maximum working pressure to be 720 PSIG and full vacuum but is limited based on valve size, valve material, and end fitting type.

PBM MODEL NUMBER (PRODUCT)(MATERIAL)(SIZE)(SERIES)(END CONNECTION)(SEAT & SEAL MATERIAL)

AUTOMATION AND CONTROLS

DIRECT MOUNT AUTOMATED BALL VALVES: VALVES AS SPECIFIED IN "MANUAL VALVES" SECTION WITH THE ADDITION OF A "DIRECT MOUNT" DOUBLE ACTING OR SPRING RETURN PNEUMATIC ACTUATOR. ACTUATOR SHALL BE OF THE DOUBLE OPPOSING PISTON, RACK AND PINION DESIGN WITH BIDIRECTIONAL PINION TRAVEL STOPS AND HARD ANODIZED ALUMINUM OXIDE BODY WITH CO-DEPOSITED FLOUROPOLYMER. END CAPS TO BE POLYESTER POWDER COATED WITH 300 SERIES STAINLESS STEEL FASTENERS. MOUNTING BRACKET SHALL BE STAINLESS STEEL AND VALVE STEM SHALL INSERT DIRECTLY INTO ACTUATOR DROVE ADAPTER. ACTUATORS SHALL BE SIZED UTILIZING A 100% SAFETY FACTOR. SPECIFY SUPPLY AIR PRESSURE AT ACTUATOR (60 OR 80 PSIG). PBM MODEL NUMBER STARTS WITH "PA". ELECTRIC ACTUATORS, LIMIT SWITCHES, POSITIONERS, SOLENOIDS, AND FIELD BUS ACCESSORIES; SPECIFY ACCORDING TO ALL STATUTORY AND REGULATORY REQUIREMENTS. INCLUDE NEMA RATING REQUIREMENTS AND ELECTRICAL CURRENT.



SP, SD Series 5; SP Series 6

Size	Size Code	Units	Port Dia. ¹	A			B			D	E	F	G			H	Approx. Weight					
				Face to Face			Q to Face						Q to Bottom B- D- Q- S- T- U	Q to Top of Handle	Handle Length from Q		End Fitting Length			Ext. Handle	B- D- Q- U-	L-
				Q- U- S- T-	B- D-	L-	Q- U- S- T-	B- D-	L-								U- Length	B-, D- Length	L- Dia.			
1/4" DN 8	A	inches	0.50	3.12	5.50	—	1.56	2.75	—	0.92	2.63	4.15	0.41	1.50	—	7.19	1.7 lbs.	4.0 lbs.				
		mm	13	79	140	—	40	70	—	23	67	105	10	38	—	183	.8 kg.	1.8 kg.				
3/8" DN 10	B	inches	0.5	3.12	5.50	—	1.56	2.75	—	0.92	2.63	4.15	0.41	1.50	—	7.19	1.7 lbs.	4.0 lbs.				
		mm	13	79	140	—	40	70	—	23	67	105	10	38	—	183	.8 kg.	1.8 kg.				
1/2" DN 15	C	inches	0.5	3.12	5.50	5.5	1.56	2.75	2.75	0.92	2.63	4.15	0.41	1.50	3.50	7.19	1.7 lbs.	4.0 lbs.				
		mm	13	79	140	140	40	70	70	23	67	105	10	38	89	183	.8 kg.	1.8 kg.				
3/4" DN 20	D	inches	0.8	3.44	5.50	5.80	1.72	2.75	2.88	1.00	2.78	4.15	0.53	1.50	3.88	7.34	2.0 lbs.	5.2 lbs.				
		mm	19	87	140	147	44	70	73	25	71	105	13	38	99	186	.9 kg.	2.4 kg.				
1" DN 25	E	inches	1.0	4.25	5.99	6.50	2.13	3.00	3.25	1.33	3.03	5.09	0.53	1.50	4.25	7.62	4.5 lbs.	8.7 lbs.				
		mm	25	108	152	165	54	76	83	34	77	129	13	38	108	194	2.0 kg.	3.9 kg.				
1-1/2" DN 40	G	inches	1.5	5.50	7.50	8.00	2.75	3.75	4.00	1.78	4.10	8.68	0.53	1.50	5.00	9.45	10.2 lbs.	17.4 lbs.				
		mm	38	140	191	203	70	95	102	45	104	221	14	38	127	240	4.6 kg.	7.9 kg.				
2" DN 50	H	inches	2.0	6.00	8.00	9.80	3.00	4.00	4.88	2.15	4.41	8.68	0.66	1.75	6.00	9.76	15.4 lbs.	26.5 lbs.				
		mm	51	152	203	249	76	102	124	55	112	220	17	44	152	248	7.0 kg.	12.0 kg.				
2-1/2" DN 65	J	inches	2.5	8.00	11.50	11.50	4.00	5.75	5.75	2.79	6.45	12.44	.69	2.31	7.00	11.36	36.0 lbs.	53.5 lbs.				
		mm	64	203	292	292	102	146	146	71	164	316	18	59	178	289	16.3 kg.	24.3 kg.				
3" DN 80	K	inches	3.0	9.00	13.50	12.80	4.50	6.75	6.38	3.14	6.78	12.44	0.69	2.31	7.50	11.69	48 lbs.	68 lbs.				
		mm	76	229	343	325	114	171	162	80	172	316	18	59	191	297	21.8 kg.	30.8 kg.				
4" DN 100	L	inches	4.0	12.00	16.00	15.00	6.00	8.00	7.50	4.91	7.34	24.40	0.81	2.31	9.00	13.97	109 lbs.	157 lbs.				
		mm	102	305	406	381	152	203	191	125	186	620	21	59	229	355	49.4 kg.	71.2 kg.				
6" DN 150	M	inches	6.0	—	22.00	20.00	—	11.00	10.00	7.25	*Note 3	*Note 3	CF	3.75	11.00	CF	CF	CF				
		mm	152	—	559	508	—	279	254	184	*Note 3	*Note 3	CF	95	279	CF	CF	CF				

NOTE: * Lever Handle not recommended.

1. Full Port
2. CF = Consult Factory.
3. Gear operator is recommended if not actuated.

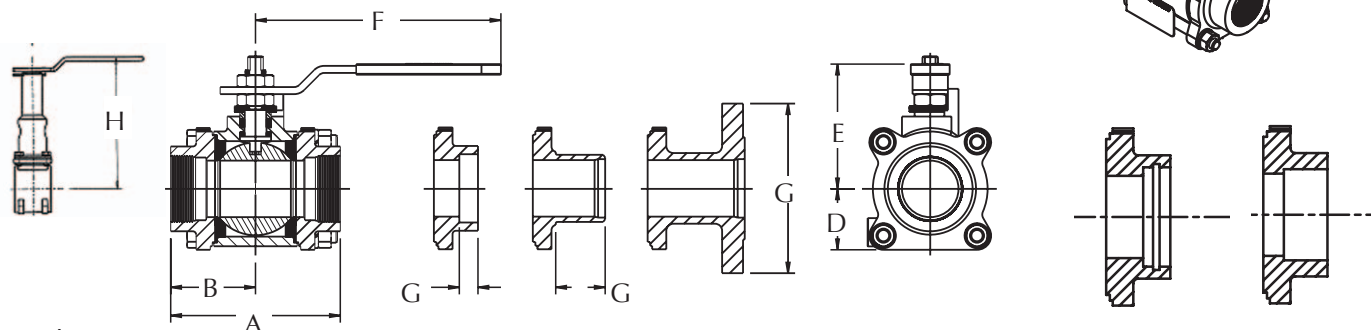
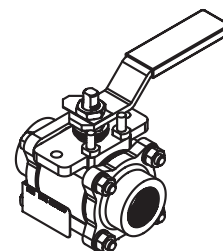

Optional
Extended
Locking
Handle

Female NPT
Q-

Socket
Weld
U-

Butt Weld
B-
D-

150#
Flange
L-

Silver
Braze
S-

Solder
Joint
T-

SP, SD Series 5; SP SERIES 6 Actuated

TFM™ or VTFE SEAT MATERIAL												
Valve Size	Actuator	Air Pressure		A		B		C		D		E
		psig	barg	inches	mm	inches	mm	inches	mm	inches	mm	NPT
1/4", 3/8", 1/2" DN 8, 10, 15	Double Acting	60, 80	4.1/5.5	5.55	141	2.80	71	5.84	148	1.61	41	1/8
	Spring Return	80	5.5	5.55	141	2.80	71	5.84	148	1.61	41	1/8
	Spring Return	60	4.1	6.46	164	3.17	81	6.29	160	1.77	45	1/8
3/4" DN 20	Double Acting	60, 80	4.1/5.5	5.55	141	2.80	71	5.99	152	1.61	41	1/8
	Spring Return	60, 80	4.1/5.5	6.46	164	3.17	81	6.44	164	1.77	45	1/8
1" DN 25	Double Acting	60, 80	4.1/5.5	5.55	141	2.80	71	6.64	169	1.61	41	1/8
	Spring Return	60, 80	4.1/5.5	8.27	210	3.72	94	7.80	198	2.07	53	1/8
1-1/2" DN 40	Double Acting	80	5.5	6.46	164	3.17	81	8.39	213	1.77	45	1/8
	Double Acting	60	4.1	8.27	210	3.72	94	9.10	231	2.07	53	1/8
	Spring Return	60, 80	4.1/5.5	10.83	275	4.84	123	10.15	258	2.68	68	1/4
2" DN 50	Double Acting	80	5.5	8.27	210	3.72	94	9.41	239	2.07	53	1/8
	Double Acting	60	4.1	8.27	210	3.72	94	9.41	239	2.07	53	1/8
	Spring Return	80	5.5	10.83	275	4.84	123	10.46	266	2.68	68	1/4
	Spring Return	60	4.1	13.11	333	5.39	137	11.82	300	2.87	73	1/4
2-1/2" DN 65	Double Acting	60, 80	4.1/5.5	13.11	333	5.39	137	13.48	342	2.87	73	1/4
	Spring Return	80	5.5	13.11	333	5.39	137	13.48	342	2.87	73	1/4
	Spring Return	60	4.1	14.65	372	5.83	148	13.96	355	3.15	80	1/4
3" DN 80	Double Acting	60, 80	4.1/5.5	13.11	333	5.39	137	13.81	351	2.87	73	1/4
	Spring Return	80	5.5	14.65	372	5.83	148	14.29	363	3.15	80	1/4
	Spring Return	60	4.1	17.15	436	6.46	164	15.18	386	3.44	87	1/4
4" DN 100	Double Acting	60, 80	4.1, 5.5	17.15	436	6.46	164	17.34	440	3.44	87	1/4
	Spring Return	60, 80	4.1, 5.5	19.69	500	7.36	187	18.28	464	3.94	100	1/4
6" DN 150	Double Acting	60, 80	4.1/5.5	22.78	579	8.58	218	24.13	613	4.29	109	1/4
	Spring Return	80	5.5	22.78	579	8.58	218	24.13	613	4.29	109	1/4
	Spring Return	60	4.1	26.46	672	11.42	290	28.89	734	5.71	145	1/4

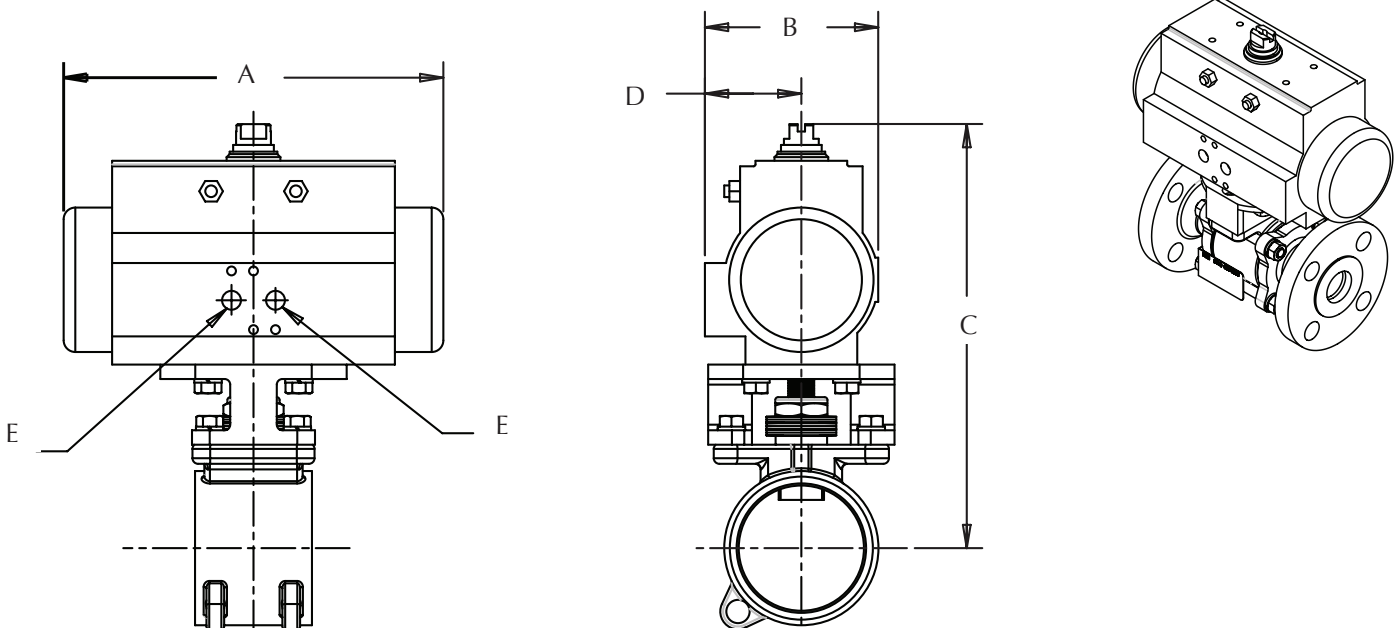

AN Series 5, 6 150 & CL300

Size	Units	Port Diameter	A		B		C		D	E	Approx. Weight			
			Overall Length		Q to End		Flange Diameter				Q to Top of Handle	Handle Length from Q	150#	300#
			150#	300#	150#	300#	150#	300#						
1/2" DN 15	inches	0.5	4.25	5.50	1.85	2.52	3.50	3.75	2.66	4.15	3.5 lbs.	4.8		
	mm	13	108	140	47	64	89	95	68	105	1.6 kg.	2.2		
3/4" DN 20	inches	0.8	4.62	6.00	2.12	2.90	3.88	4.62	2.78	4.15	6.8 lbs.	7.3		
	mm	19	117	152	54	74	99	117	71	105	3.1 kg.	3.3		
1" DN 25	inches	1.00	5.00	6.50	2.25	3.15	4.25	4.88	3.09	5.06	8 lbs.	11		
	mm	25	127	165	57	80	108	124	78	129	3.6 kg.	5.0		
1-1/2" DN 40	inches	1.50	6.50	7.50	2.68	3.18	5.00	6.12	4.16	8.03	16 lbs.	23		
	mm	38	165	191	68	81	127	155	106	204	7.3 kg.	10.4		
2" DN 50	inches	2.00	7.00	8.50	3.12	3.84	6.00	6.50	4.46	8.03	25 lbs.	30		
	mm	51	178	216	79	98	152	165	113	204	11.3 kg.	13.6		
3" DN 80	inches	3.00	8.00	11.12	3.57	5.19	7.50	8.25	7.00	12.06	50 lbs.	71		
	mm	76	203	282	91	132	191	210	178	306	22.7 kg.	32.2		
4" DN 100	inches	4.00	9.00	12.00	3.84	5.34	9.00	10.00	7.39	24.06	96 lbs.	130		
	mm	102	229	305	98	136	229	254	188	611	43.5 kg.	59.0		
6" DN 150	inches	6.07	15.50	CF	7.33	CF	11.00	CF	Note 3	Note 3	Note 4	CF		
	mm	154	394	CF	186	CF	279	CF	Note 3	Note 3	Note 4	CF		

Notes:

1. All dimensions are in inches, weights in lbs.
2. Valve is shown in open position.
3. Lever handle is not recommended for 6" valves.
4. Valve approximate weight without handle - 242 lbs.

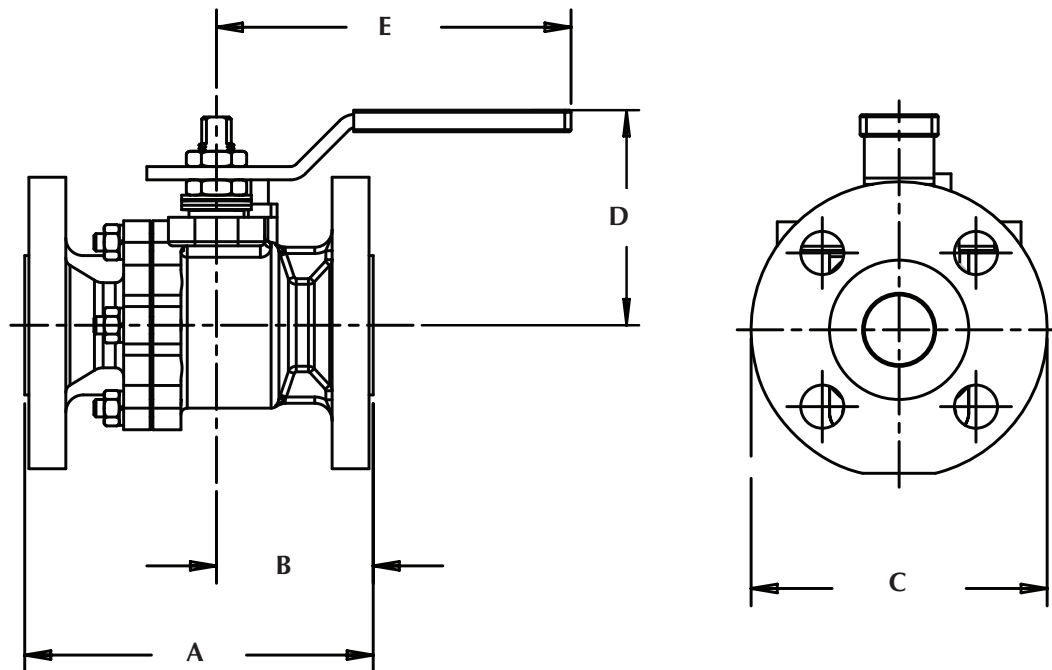
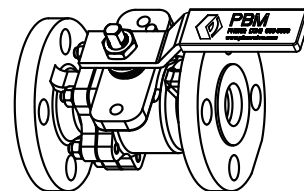

AN Series 5, 6 Actuated

TFM™ OR VTFE SEAT MATERIAL																		
Size	Actuator	Air Pressure		A		B		C		D		E		F		G		H
		psig	barg	inches	mm	inches	mm	inches	mm	inches	mm	inches	mm	inches	mm	inches	mm	NPT
1/2" DN 15	Double Acting Spring Return	60, 80	4.1/5.5	4.25	108	1.85	47	3.50	89	5.50	139.7	2.79	71	5.84	148	1.61	41	1/8
3/4" DN 20	Double Acting Spring Return	60, 80	4.1/5.5	4.62	117	2.12	54	3.88	99	6.38	162	3.17	81	6.44	164	1.77	45	1/8
1" DN 25	Double Acting	60, 80	4.1/5.5	5.00	127	2.25	57	4.25	108	5.55	141	2.80	71	6.71	170	1.61	41	1/8
	Spring Return	60, 80	4.1/5.5	5.00	127	2.25	57	4.25	108	8.27	210	3.72	94	7.87	200	2.07	53	1/8
1-1/2" DN 40	Double Acting	80	5.5	6.50	165	2.68	68	5.00	127	6.46	164	3.17	81	8.44	214	1.77	45	1/8
	Double Acting	60	4.1	6.50	165	2.68	68	5.00	127	8.27	210	3.72	94	9.15	232	2.07	53	1/8
	Spring Return	60, 80	4.1/5.5	6.50	165	2.68	68	5.00	127	10.83	275	4.84	123	10.20	259	2.68	68	1/4
2" DN 50	Double Acting	60, 80	4.1/5.5	7.00	178	3.12	79	6.00	152	8.27	210	3.72	94	9.46	240	2.07	53	1/8
	Spring Return	80	5.5	7.00	178	3.12	79	6.00	152	10.83	275	4.84	123	10.51	267	2.68	68	1/4
	Spring Return	60	4.1	7.00	178	3.12	79	6.00	152	13.11	333	5.39	137	11.87	301	2.87	73	1/4
3" DN 80	Double Acting	60, 80	4.1/5.5	8.00	203	3.57	91	7.50	191	13.11	333	5.39	137	13.81	351	2.87	73	1/4
	Spring Return	80	5.5	8.00	203	3.57	91	7.50	191	14.65	372	5.83	148	14.29	363	3.15	80	1/4
	Spring Return	60	4.1	8.00	203	3.57	91	7.50	191	17.13	435	6.46	164	15.18	386	3.44	87	1/4
4" DN 100	Double Acting	60, 80	4.1/5.5	9.00	229	3.84	98	9.00	229	17.13	435	6.46	164	17.34	440	3.44	87	1/4
	Spring Return	80	5.5	9.00	229	3.84	98	9.00	229	19.69	500	7.36	187	18.28	464	3.94	100	1/4
	Spring Return	60	5.5	9.00	229	3.84	98	9.00	229	22.78	579	7.36	187	20.53	521	3.94	100	1/4
6" DN 150	Double Acting	60, 80	4.1/5.5	15.50	394	7.33	186	11.00	279	22.78	579	8.58	218	24.11	612	4.29	109	1/4
	Spring Return	80	5.5	15.50	394	7.33	186	11.00	279	22.78	579	8.58	218	24.11	612	4.29	109	1/4
	Spring Return	60	4.1	15.50	394	7.33	186	11.00	279	26.46	672	11.42	290	28.87	733	5.71	145	1/4

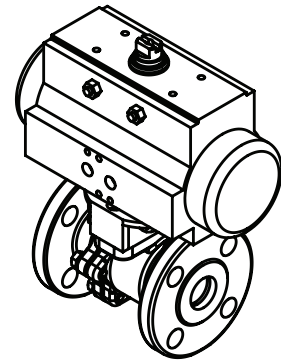
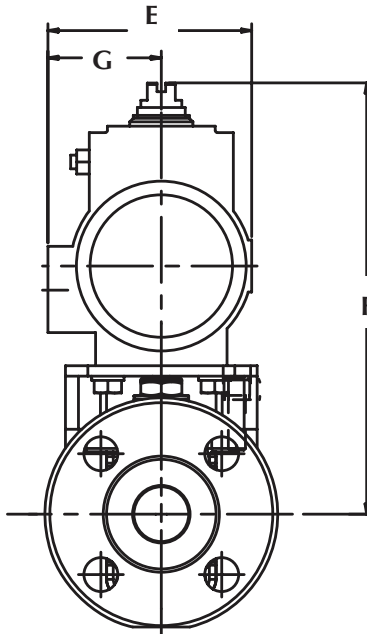
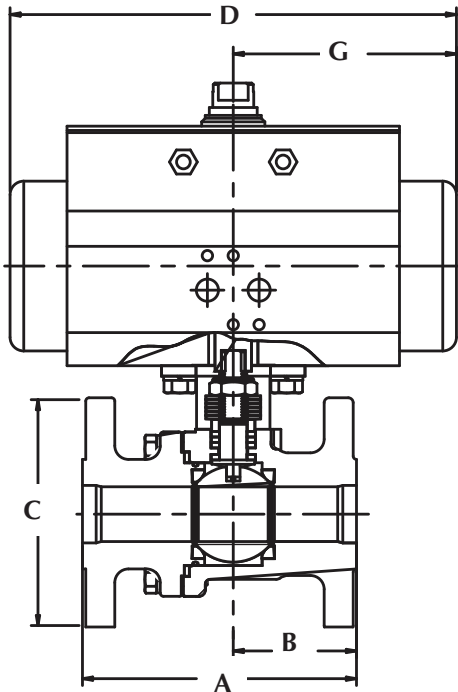

AN Series 1 CL150

Size	Units	Port	A	B	D	E	F	G	Approx. Weight Bronze
			Overall Length	℄ to End	℄ to Bottom	℄ to Top of Handle	Handle Length from ℄	Flange Diameter	
1/2" DN 15	inches	0.50	4.25	1.84	1.62	3.07	5.09	3.50	6 lbs.
	mm	13	108	47	41	78	129	89	2.7 kg.
3/4" DN 20	inches	0.75	4.62	2.01	1.88	3.14	5.09	3.88	9 lbs.
	mm	19	117	51	48	80	129	99	4.1 kg.
1" DN 25	inches	1.00	5.00	2.20	2.06	4.33	6.09	4.25	10 lbs.
	mm	25	127	56	52	110	155	108	4.5 kg.
1-1/2" DN 40	inches	1.50	6.50	2.78	2.38	5.25	8.68	5.00	20 lbs.
	mm	38	165	71	60	133	220	127	9.1 kg.
2" DN 50	inches	2.00	7.00	2.99	2.88	5.56	8.68	6.00	24 lbs.
	mm	51	178	76	73	141	220	152	10.9 kg.
3" DN 80	inches	3.00	8.00	3.62	4.56	7.08	12.44	7.50	92 lbs.
	mm	76	203	92	116	180	316	191	41.7 kg.
4" DN 100	inches	4.00	9.00	3.84	4.75	7.93	14.44	9.00	118 lbs.
	mm	102	229	98	121	201	367	229	53.5 kg.
6" DN 150	inches	6.00	15.50	7.33	7.25	N/A	N/A	11.00	330 lbs.
	mm	152	394	186	184	N/A	N/A	279	149.7 kg.
8" DN 200	inches	8.00	18.00	8.50	9.30	N/A	N/A	13.50	600 lbs.
	mm	203	457	216	236	N/A	N/A	343	275 kg.
10" DN 250	inches	10.00	21.00	CF	CF	N/A	N/A	16.00	CF
	mm	254	533	CF	CF	N/A	N/A	406	CF

NOTES:

1. Standard product is 316 Stainless Steel. Carbon Steel, Bronze and other materials are available upon request. Consult PBM.
2. Dimensions meet ASME Standard B16.10 long pattern.
3. Stainless Steel valves and Carbon Steel valves have raised face flanges, but are also available with flat faced flanges. Bronze valves have flat face flanges only.
4. Drawings are for illustration purposes only. Consult PBM prior to any fabrication or installation work.

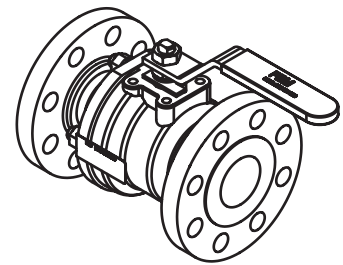
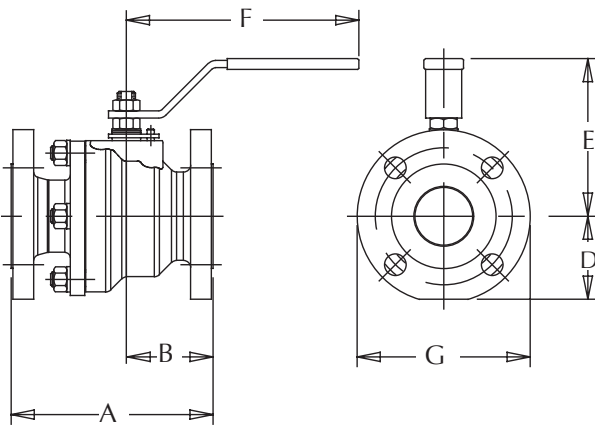

AN Series 1 Actuated

RTFE OR UHMWPE SEAT MATERIAL												
Size	Actuator	Air Pressure		A		B		C		D		E
		psig	barg	inches	mm	inches	mm	inches	mm	inches	mm	NPT
1/2" DN 15	Double Acting	60, 80	4.1/5.5	5.55	141	2.80	71	6.30	160	1.61	41	1/8
	Spring Return	80	5.5	6.46	164	3.17	81	6.30	160	1.77	45	1/8
	Spring Return	60	4.1	8.27	210	3.72	94	6.75	171	2.07	53	1/8
3/4" DN 20	Double Acting	60, 80	4.1/5.5	5.55	141	2.80	71	6.41	163	1.61	41	1/8
	Spring Return	60, 80	4.1/5.5	6.46	164	3.17	81	6.86	174	1.77	45	1/8
1" DN 25	Double Acting	60, 80	4.1/5.5	5.50	140	2.80	71	7.64	194	1.61	41	1/8
	Spring Return	80	5.5	8.27	210	3.72	94	8.80	224	2.07	53	1/8
	Spring Return	60	4.1	9.47	241	4.17	106	8.80	224	2.30	58	1/8
1-1/2" DN 40	Double Acting	80	5.5	8.27	210	3.72	94	8.97	228	2.07	53	1/8
	Double Acting	60	4.1	8.27	210	3.72	94	8.97	228	2.07	53	1/8
	Spring Return	80	5.5	10.83	275	4.84	123	9.52	241	2.67	68	1/4
	Spring Return	60	4.1	13.11	333	5.39	137	10.02	255	2.87	73	1/4
2" DN 50	Double Acting	60, 80	4.1/5.5	8.27	210	3.72	94	9.28	236	2.07	53	1/8
	Spring Return	80	5.5	10.83	275	4.84	123	10.33	262	2.67	68	1/4
	Spring Return	60	4.1	13.11	333	5.39	137	10.33	262	2.87	73	1/4
3" DN 80	Double Acting	60, 80	4.1/5.5	13.11	333	5.39	137	14.25	362	2.87	73	1/4
	Spring Return	80	5.5	14.65	372	5.83	148	14.73	374	3.15	80	1/4
	Spring Return	60	4.1	17.13	435	6.46	164	15.62	397	3.44	87	1/4
4" DN 100	Double Acting	80	5.5	13.11	333	5.39	137	17.26	438	2.87	73	1/4
	Double Acting	60	4.1	14.65	372	6.46	164	17.26	438	3.44	87	1/4
	Spring Return	60, 80	4.1/5.5	19.69	500	7.36	187	19.57	497	3.94	100	1/4
6" DN 150	Double Acting	60, 80	4.1/5.5	19.69	500	7.36	187	21.54	547	3.94	100	1/4
	Spring Return	80	5.5	22.78	579	8.58	218	23.79	604	4.29	109	1/4
	Spring Return	60	4.1	26.46	672	11.42	290	28.55	725	5.71	145	1/4

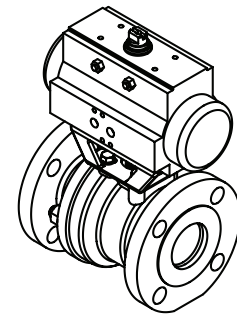
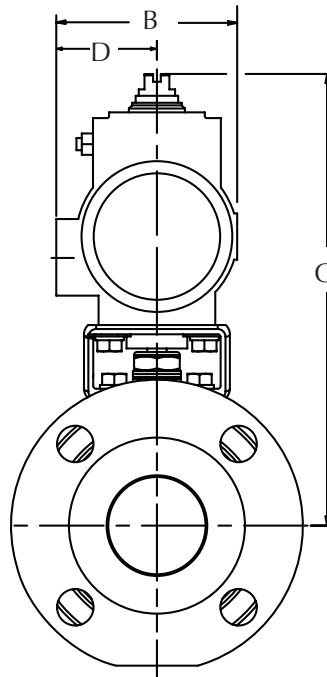
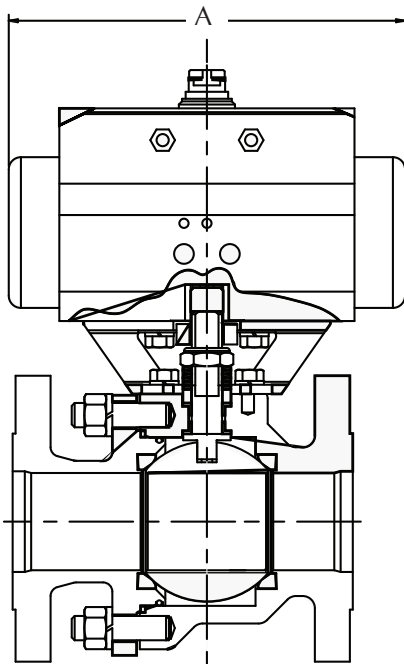

FT, FD Series 5; FT Series 6

Female NPT (Q-), Socket Weld (U-), Butt Weld for Sched. 40 (B-), Butt Weld for Sched. 40 (B-) 150# Flange (L-)

Size	Code	Units	Port Dia. ¹	A			B			D	E	F	G	H	I	Approx. Weight	
				Face to Face			C _l to Face			C _l to Bottom B- D- Q-, U-	C _l to Top of Handle	Handle Length from C _l	Butt Weld Length	Pad Dia.	Pad Thickness *	B-, Q- U-	L-
				Q- U-	B- D-	L-	Q- U-	B- D-	L-							B-, Q- U-	L-
1/2" DN 15	C	inches	.5	2.83	4.02	4.02	1.56	2.75	2.75	.98	2.63	4.15	1.50	2.75	0.28	2 lbs.	3 lbs.
		mm	13	72	102	102	40	70	70	23	67	105	38	70	7.1	.9 kg.	1.4 kg.
3/4" DN 20	D	inches	.8	3.07	4.10	4.23	1.72	2.75	2.88	1.0	2.78	4.15	1.50	3.00	0.31	2.5 lbs.	4 lbs.
		mm	19	78	104	107	44	70	73	25	71	105	38	70	7.1	1.1 kg.	1.8 kg.
1" DN 25	E	inches	1.0	3.84	4.71	4.96	2.13	3.00	3.25	1.33	3.1	5.09	1.50	3.75	0.32	5 lbs.	7 lbs.
		mm	25	98	120	126	54	76	83	34	78	129	38	95	8.1	2.3 kg.	3.2 kg.
1-1/2" DN 40	G	inches	1.5	5.07	6.07	6.32	2.75	3.75	4.00	1.78	4.41	8.68	1.50	5.50	0.46	13 lbs.	16 lbs.
		mm	38	129	154	161	70	95	102	45	111	221	38	140	11.7	5.9 kg.	7.3 kg.
2" DN 50	H	inches	2.0	5.66	6.66	7.54	3.00	4.00	4.88	2.2	4.7	8.68	1.75	6.50	0.49	19 lbs.	25 lbs.
		mm	51	144	169	192	76	102	124	55	119	221	45	165	12.4	8.6 kg.	11.3 kg.
3" DN 80	K	inches	3.0	8.38	10.63	10.26	4.50	6.75	6.38	3.1	6.78	12.44	2.31	9.00	0.77	57 lbs.	68 lbs.
		mm	76	213	270	261	114	171	162	80	174	315	59	229	19.6	25.9 kg.	30.8 kg.
4" DN 100	L	inches	4.0	10.81	12.81	12.31	6.00	8.00	7.50	4.9	7.34	24.44	2.31	11.50	0.90	120 lbs.	133 lbs.
		mm	102	275	325	313	152	203	191	125	186	611	59	292	22.9	54.4 kg.	60.3 kg.
6" DN 150	M	inches	6.0	—	17.80	16.80	—	11.00	10.00	7.2	Note 2	CF	3.75	17.00	1.23	CF	CF
		mm	154	—	452	427	—	279	254	182	Note 2	CF	95	432	31.2	CF	CF

NOTES:

- * For pad thickness requirements greater than those listed, consult PBM.
- 1. Full Port
- 2. Gear Operator recommended.
- 3. CF = Consult Factory
- 4. Consult factory for approximate weight of 6" valves with Butt Weld for Sched. 40 (B-) end fitting.
- 5. Male NPT, Solder Joint, Sil-Brace, Camlock, and Grooved end fittings are also available.
- 6. B- dimensions shown meet Schedule 40. End fittings are also available to meet Schedule 10s or Schedule 5s.
- 7. 1/2" through 3" have 4 bolts. 4" through 8" valves have 8 bolts.
- 8. Flange holes straddle the center line, except for the 1-1/2" size.
- 9. Drawings are for illustration purposes only. Consult PBM prior to any fabrication or installation.
- 10. When using optional cylindrical radius pads, pocket area may increase. Consult PBM if reduced pocket area is desired. Note reduced pocket may decrease valve pressure rating.

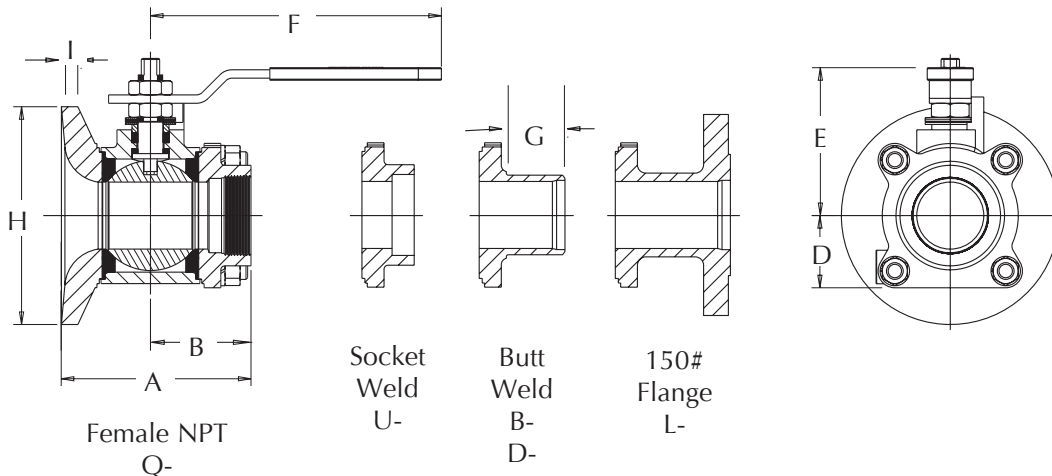
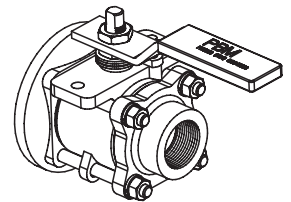

FT, FD Series 5; FT Series 6 Actuated

TFM™ OR VTFE SEAT MATERIAL														
Size	Actuator Type	Air Supply		A		B		C		D		E	F	
		psig	barg	inches	mm	inches	mm	inches	mm	inches	mm	NPT	inches	mm
1/2" DN 15	Double Acting	60, 80	4.1/5.5	5.55	141	2.80	71	5.84	148	1.61	41	1/8	0.09	2
	Spring Return	80	5.5	5.55	141	2.80	71	5.84	148	1.61	41	1/8	0.09	2
	Spring Return	60	4.1	6.46	164	3.17	81	6.29	160	1.77	45	1/8	-0.13	-3
3/4" DN 20	Double Acting	60, 80	4.1/5.5	5.55	141	2.80	71	5.99	152	1.61	41	1/8	0.17	4
	Spring Return	60, 80	4.1/5.5	6.46	164	3.17	81	6.44	164	1.77	46	1/8	-0.05	-1
1" DN 25	Double Acting	60, 80	4.1/5.5	5.55	141	2.80	71	6.64	169	1.61	41	1/8	0.53	13
	Spring Return	60, 80	4.1/5.5	8.27	210	3.72	94	7.8	198	2.07	53	1/8	0.06	2
1-1/2" DN 40	Double Acting	80	5.5	6.46	164	3.17	81	8.39	213	1.77	45	1/8	0.92	23
	Double Acting	60	4.1	8.27	210	3.72	94	9.1	231	2.07	53	1/8	0.67	17
	Spring Return	60, 80	4.1/5.5	10.83	275	4.84	123	10.15	258	2.68	68	1/4	0.15	4
2" DN 50	Double Acting	60, 80	4.1/5.5	8.27	210	3.72	94	9.41	239	2.07	53	1/8	1.01	26
	Spring Return	80	5.5	10.83	275	4.84	123	10.46	266	2.68	68	1/4	0.49	12
	Spring Return	60	4.1	13.11	333	5.39	137	11.82	300	2.87	73	1/4	0.14	4
3" DN 80	Double Acting	60, 80	4.1/5.5	13.11	333	5.39	137	13.81	351	2.87	73	1/4	1.36	35
	Spring Return	80	5.5	14.65	372	5.83	148	14.29	363	3.15	80	1/4	1.20	30
	Spring Return	60	4.1	17.15	436	6.46	164	15.18	386	3.44	87	1/4	0.85	22
4" DN 100	Double Acting	60, 80	4.1/5.5	17.15	436	6.46	164	17.34	440	3.44	87	1/4	1.78	45
	Spring Return	60, 80	4.1/5.5	19.69	500	7.36	187	18.28	464	3.94	100	1/4	1.38	35
6" DN 150	Double Acting	60, 80	4.1/5.5	22.78	579	8.58	218	24.13	613	4.29	109	1/4	2.51	64
	Spring Return	80	5.5	22.78	579	8.58	218	24.13	613	4.29	109	1/4	2.51	64
	Spring Return	60	4.1	26.46	672	11.42	290	28.89	734	5.71	145	1/4	1.09	28

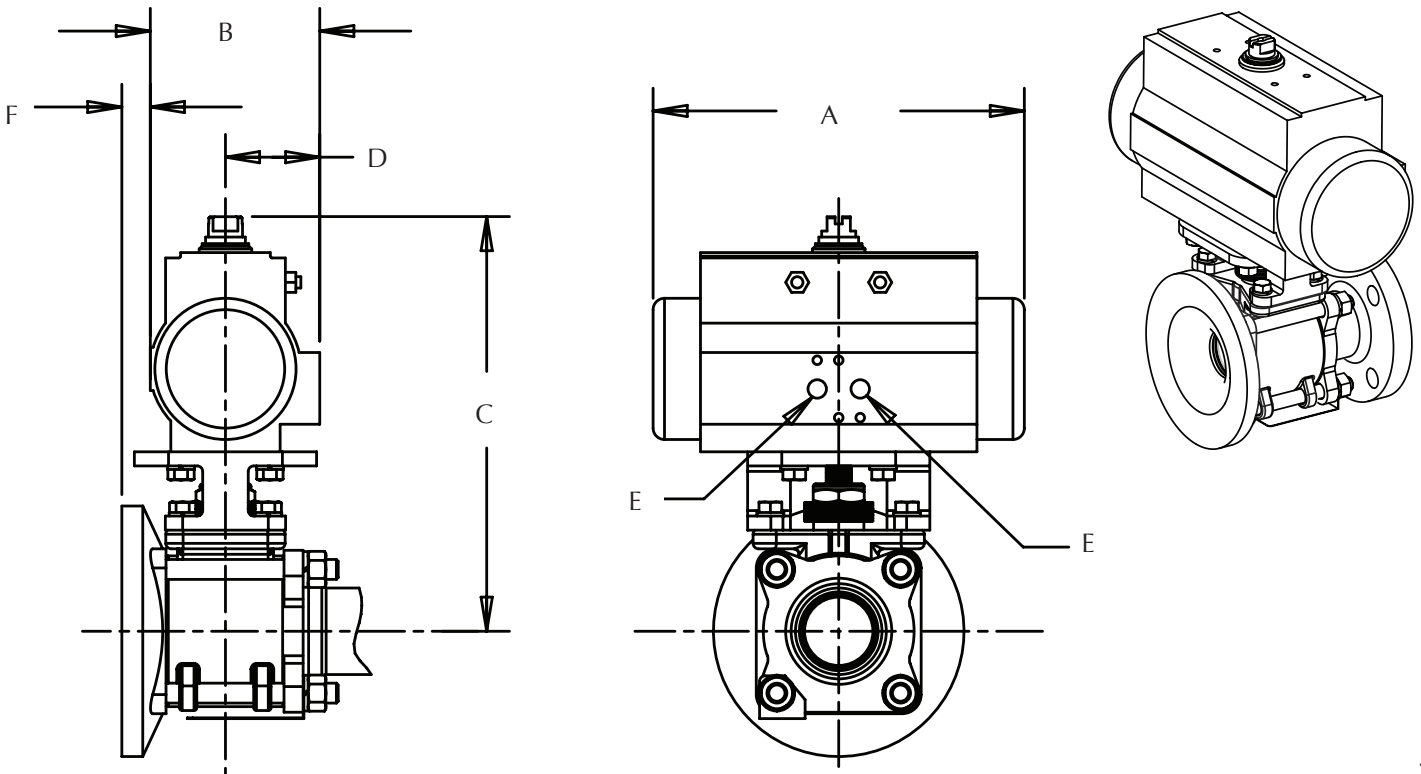

AF Series 1 & 3

Size	Units	B Port	C		D		H Pad Diameter	I Pad Thickness	J Handle Length
			Face-to-Face		℄ to End				
			Q-, B-, U-	L-	Q-, B-, U-	L-			
1" DN 25	inches	1.00	3.58	4.14	1.94	2.50	3.70	0.53	6.09
	mm	25	91	105	49	64	94	13	155
1-1/2" DN 40	inches	1.50	4.97	5.53	2.69	3.25	5.50	0.62	8.07
	mm	38	126	140	68	83	140	16	205
2" DN 50	inches	2.00	5.53	6.17	2.86	3.50	7.00	0.68	8.07
	mm	51	140	157	73	89	178	17	205
3" DN 80	inches	2.75	8.38	9.19	4.31	5.12	10.00	0.79	12.06
	mm	70	213	233	109	130	254	20	306
4" DN 100	inches	3.50	9.52	10.48	5.24	6.20	11.50	0.91	12.06
	mm	89	242	266	133	157	292	23	306
6" DN 150	inches	5.25	12.12	15.61	6.56	10.05	15.00	1.04	15.06
	mm	133	308	396	167	255	381	26	383

*Buttweld end; Q and U not available in 6" size.

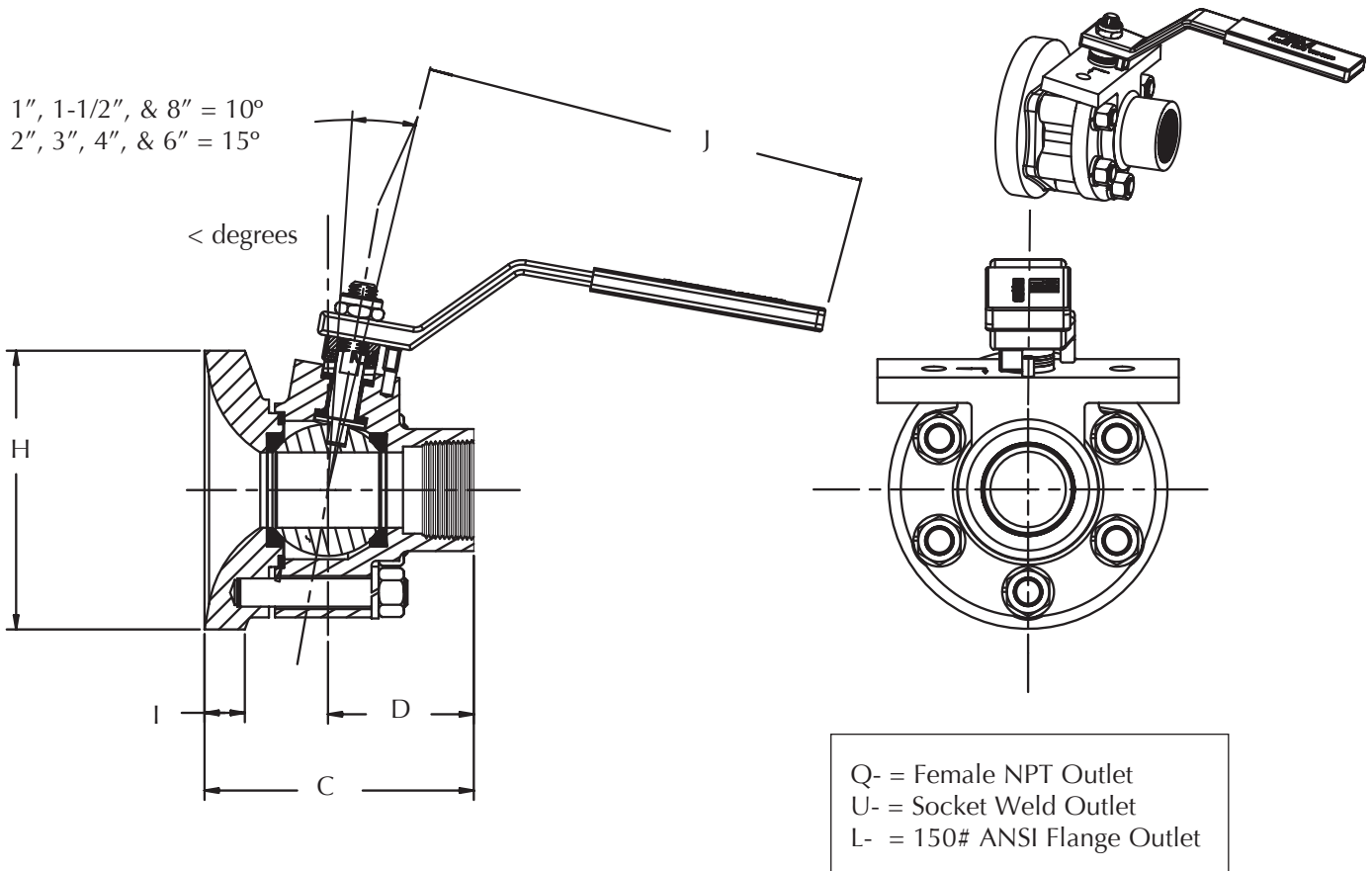

AF Series 1 & 3 Actuated

RTFE or UHMWPE Seats														
Size	Actuator Type	Air supply		Port		A		B		C		D		Air Inlet NPT
		psig	barg	inches	mm	inches	mm	inches	mm	inches	mm	inches	mm	
1" DN 25	Double Acting	80	5.5	1.00	25.4	5.55	141	2.80	71	0.85	22	6.67	169	1/8
	Double Acting	60	4.1			5.55	141	3.17	81	0.85	22	6.67	169	1/8
	Spring Return	80	5.5			8.27	210	3.72	95	0.73	19	7.86	200	1/8
	Spring Return	60	4.1			8.27	210	4.17	106	0.55	14	7.86	200	1/8
1-1/2" DN 40	Double Acting	60, 80	4.1, 5.5	1.50	38.1	8.27	210	3.72	95	1.55	39	8.90	226	1/8
	Spring Return	80	5.5			9.47	241	4.17	106	1.37	35	9.40	239	1/4
	Spring Return	60	4.1			13.11	333	5.39	137	0.84	21	9.95	253	1/4
2" DN 50	Double Acting	60, 80	4.1, 5.5	2.00	50.8	8.27	210	3.72	95	2.49	63	9.06	230	1/8
	Spring Return	80	5.5			10.83	275	4.84	123	2.07	53	10.08	256	1/4
	Spring Return	60	4.1			13.11	333	5.39	137	1.86	47	11.45	291	1/4
3" DN 80	Double Acting	60, 80	4.1, 5.5	2.75	69.9	13.11	333	5.39	137	3.32	84	13.93	354	1/4
	Spring Return	80	5.5			14.65	372	5.83	148	3.32	84	14.40	366	1/4
	Spring Return	60	4.1			17.13	435	6.46	164	3.32	84	15.25	387	1/4
4" DN 100	Double Acting	60, 80	4.1, 5.5	3.50	88.9	13.11	333	5.39	137	3.66	93	14.41	366	1/4
	Spring Return	60	5.5			19.69	500	7.36	187	3.62	92	15.73	400	1/4
	Spring Return	80	4.1			17.13	435	6.46	164	3.66	93	15.73	400	1/4
6" DN 150	Double Acting	60, 80	4.1, 5.5	5.25	133.4	19.69	500	7.36	187	4.40	112	19.24	489	1/4
	Spring Return	80	5.5			22.78	579	8.58	218	4.40	112	22.42	569	1/4
	Spring Return	60	4.1			26.46	672	11.42	290	3.25	83	27.02	686	1/4

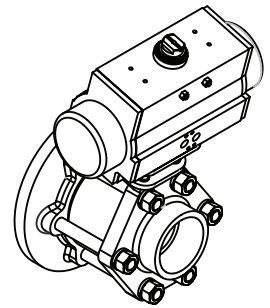
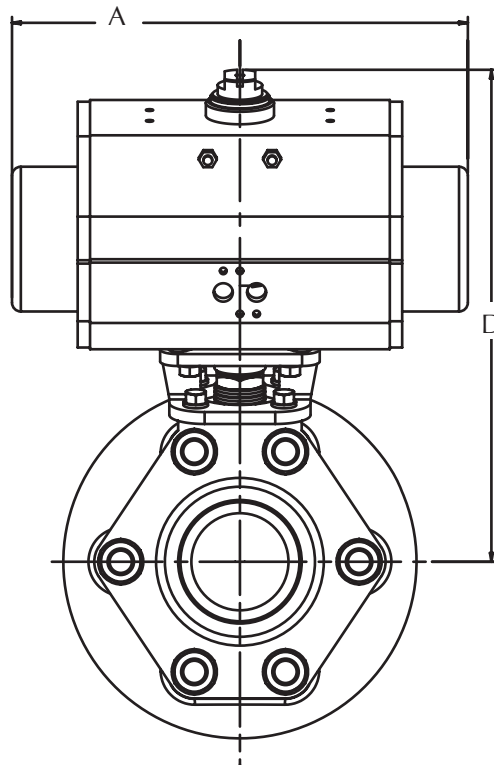
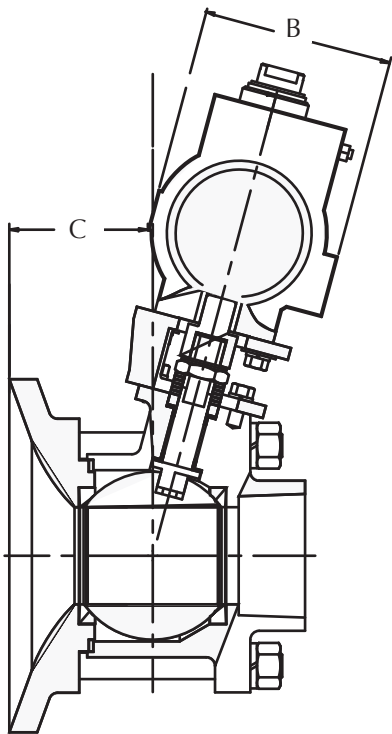

DP, DD Series 5

Female NPT (Q-), Socket weld (U-), butt Weld for Schedule 40 (B-), 150# Flange (L-)

Size	Size Code	Units	Port Dia.	A			B			C	D	E			G			Approximate Weight	
				Face-to-Face			☉ to Face			Handle Length from ☉	☉ to Top of Handle	☉ to Bottom Entry			End Fitting				
				Q-U-	B-D-	L-	Q-U-	B-D-	L-			Q-U-	B-D- Length	L-Dia.	U-Length	B-D- Length	L-Dia.	Q-, U-, B-, D-	L-
1/2" DN 15	C	inches	0.50	3.12	5.50	5.50	1.56	2.75	2.75	4.15	2.63	1.56	2.75	2.80	0.41	1.50	3.50	2 lbs.	5.2 lbs.
		mm	13	79	140	140	40	70	70	105	67	40	70	71	10	38	89	.9 kg.	2.4 kg.
3/4" DN 20	D	inches	0.75	3.44	5.50	5.75	1.72	2.75	2.88	4.15	2.78	1.72	2.75	2.88	0.53	1.50	3.88	2.5 lbs.	7 lbs.
		mm	19	87	140	146	44	70	73	105	71	44	70	73	13	38	99	1.1 kg.	3.2 kg.
1" DN 25	E	inches	1.00	4.25	5.99	6.50	2.13	3.00	3.25	5.09	3.03	2.13	3.00	3.25	0.53	1.50	4.25	5 lbs.	11 lbs.
		mm	25	108	152	165	54	76	83	129	77	54	76	83	13	38	108	2.3 kg.	5.0 kg.
1-1/2" DN 40	G	inches	1.50	5.50	7.50	8.00	2.75	3.75	4.00	8.68	4.10	2.75	3.75	4.00	0.53	1.50	5.00	11.5 lbs.	21.5 lbs.
		mm	38	140	191	203	70	95	102	220	104	70	95	102	13	38	127	5.2 kg.	9.8 kg.
2" DN 50	H	inches	2.00	6.00	8.00	9.75	3.00	4.00	4.88	8.68	4.41	3.00	4.00	4.88	0.66	1.75	6.00	16.5 lbs.	33 lbs.
		mm	51	152	203	248	76	102	124	220	112	76	102	124	17	44	152	7.5 kg.	15.0 kg.
3" DN 80	K	inches	3.00	9.00	13.50	12.75	4.50	6.75	6.38	12.44	6.78	4.50	6.75	6.38	0.69	2.31	7.50	50 lbs.	80 lbs.
		mm	76	229	343	324	114	171	162	316	172	114	171	162	18	59	191	22.7 kg.	36.3 kg.
4" DN 100	L	inches	4.00	12.00	16.00	15.00	6.00	8.00	7.50	24.40	7.34	6.00	8.00	7.50	0.81	2.31	9.00	123 lbs.	155 lbs.
		mm	102	305	406	381	152	203	191	620	186	152	203	191	21	59	229	55.8 kg.	70.3 kg.
6" DN 150	M	inches	6.00	CF	22.00	20.00	CF	11.00	10.00	Note 1	Note 1	9.00	11.00	10.00	CF	3.75	11.00	CF	CF
		mm	152	CF	559	508	CF	279	254	Note 1	Note 1	229	279	254	CF	95	279	CF	CF

Notes:

1. Gear operator is recommended.
2. Other end fittings are also available. See page 16 and 18.
3. Other flanged end fittings are available upon special request.
4. Butt Weld ends are also available in Schedule 10s & Schedule 5s.
5. 1/2" – 3" size valves have 4 bolts. 4" and 6" sizes have 8 bolts.
6. Drawings are for illustration purposes only.
7. Using a welded connection on the common port of a DP valve may complicate maintenance. Provisions must be made to allow removal of end fittings and body from the line. PBM recommends Female NPT (Q-) or flanged end fittings for common port connection for ease of valve maintenance.

Refer to Page 12 for Flow Pattern Options

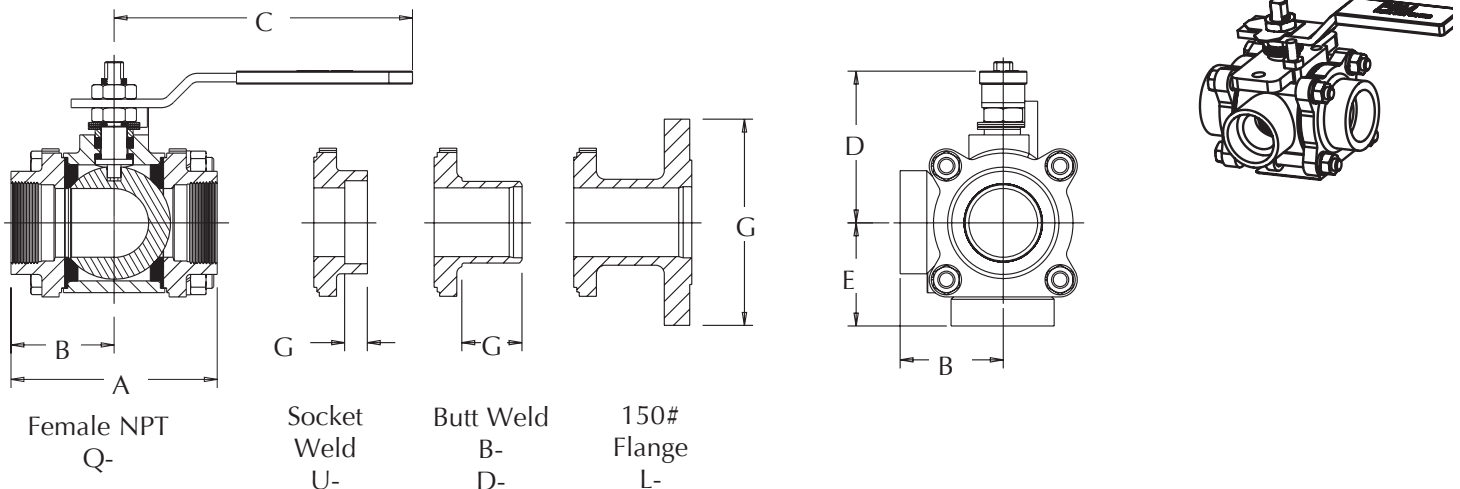

DP, DD Series 5 Actuated

Size	Actuator Type	TFM™ or VTFE SEAT MATERIAL										
		Air Supply		A		B		C		D		E
		psig	barg	inches	mm	inches	mm	inches	mm	inches	mm	NPT
1/2" DN 15	Double Acting	60, 80	4.1, 5.5	5.55	141	2.80	71	5.84	148	1.61	41	1/8
	Spring Return	80	5.5	5.55	141	2.80	71	5.84	148	1.61	41	1/8
	Spring Return	60	4.1	6.46	164	3.17	81	6.29	160	1.77	45	1/8
3/4" DN 20	Double Acting	60, 80	4.1, 5.5	5.55	141	2.80	71	5.99	152	1.61	41	1/8
	Spring Return	60, 80	4.1, 5.5	6.46	164	3.17	81	6.44	164	1.77	45	1/8
1" DN 25	Double Acting	60, 80	4.1, 5.5	5.55	141	2.8	71	6.64	169	1.61	41	1/8
	Spring Return	60, 80	4.1, 5.5	8.27	210	3.72	94	7.80	198	2.07	53	1/8
1-1/2" DN 40	Double Acting	80	5.5	6.46	164	3.17	81	8.39	213	1.77	45	1/8
	Double Acting	60	4.1	8.27	210	3.72	94	9.10	231	2.07	53	1/8
	Spring Return	60, 80	4.1, 5.5	10.83	275	4.84	123	10.15	258	2.68	68	1/4
2" DN 50	Double Acting	80	5.5	8.27	210	3.72	94	9.41	239	2.07	53	1/8
	Double Acting	60	4.1	8.27	210	3.72	94	9.41	239	2.07	53	1/8
	Spring Return	80	5.5	10.83	275	4.84	123	10.46	266	2.68	68	1/4
	Spring Return	60	4.1	13.11	333	5.39	137	11.82	300	2.87	73	1/4
3" DN 80	Double Acting	60, 80	4.1, 5.5	13.11	333	5.39	137	13.81	351	2.87	73	1/4
	Spring Return	80	5.5	14.65	372	5.83	148	14.29	363	3.15	80	1/4
	Spring Return	60	4.1	17.15	436	6.46	164	15.18	386	3.44	87	1/4
4" DN 100	Double Acting	60, 80	4.1, 5.5	17.15	436	6.46	164	17.34	440	3.44	87	1/4
	Spring Return	60, 80	4.1, 5.5	19.69	500	7.36	187	18.28	464	3.94	100	1/4
6" DN 150	Double Acting	60, 80	4.1, 5.5	22.78	579	8.58	218	24.13	613	4.29	109	1/4
	Spring Return	80	5.5	22.78	579	8.58	218	24.13	613	4.29	109	1/4
	Spring Return	60	4.1	26.46	672	11.42	290	28.89	734	5.71	145	1/4

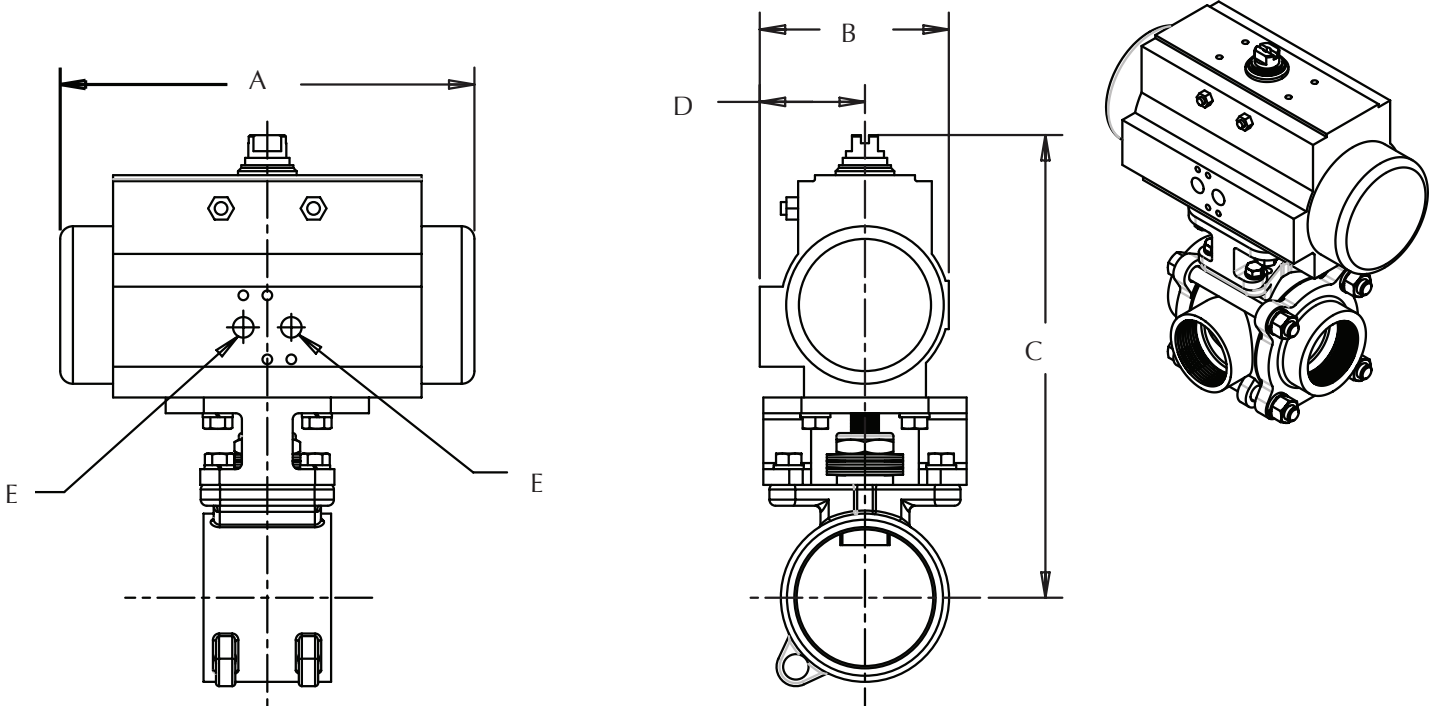

MP Series 5

A	Size	Units	B	C ₁		D ₁		C ₂		D ₂		E	F	G ₁	G ₂	H	I	Approx. Weight S/S	
				Face to Face		℄ to Face		Face to Face		℄ to Face									
				Q/U-B-	L-	Q/U-B-	L-	Q/U-B-	L-	Q/U-B-	L-								
1/2" DN 15	C	inches	0.50	4.50	CF	2.25	CF	4.25	CF	2.25	CF	5.09	3.1	1.44	2.25	0.87	CF	7 lbs.	
		mm	13	114	CF	57	CF	108	CF	57	CF	129	79	37	57	22	CF	3.2 kg.	
3/4" DN 20	D	inches	0.75	4.50	CF	2.25	CF	4.25	CF	2.25	CF	5.09	3.1	1.44	2.25	1.08	CF	7 lbs.	
		mm	19	114	CF	57	CF	108	CF	57	CF	129	79	37	57	27	CF	3.2 kg.	
1" DN 25	E	inches	1.00	4.75	7.50	2.38	3.75	4.61	6.00	2.38	3.75	8.03	4.0	1.67	2.38	1.34	4.25	10.5 lbs.	
		mm	25	121	191	60	95	117	152	60	95	204	102	42	60	34	108	4.8 kg.	
1-1/2" DN 40	G	inches	1.50	6.50	10.00	3.25	5.00	6.38	8.13	3.25	5.00	11.56	5.53	2.22	3.25	1.93	5.00	26.8 lbs.	
		mm	38	165	254	83	127	162	207	83	127	294	140	56	83	49	127	12.2 kg.	
2" DN 50	H	inches	2.00	7.50	11.50	3.75	5.75	7.4	9.46	3.75	5.75	11.56	6.00	2.70	3.75	2.42	6.00	40.5 lbs.	
		mm	51	191	292	95	146	188	240	95	146	294	152	69	95	61	152	18.4 kg.	
3" DN 80	K	inches	3.00	12.00	16.50	6.00	8.25	11.46	13.71	6	8.25	CF	CF	3.75	CF	3.55	7.50	100 lbs.	
		mm	76	305	419	152	210	291	348	152	210	CF	CF	95	CF	90	191	45.4 kg.	
4" DN 100	L	inches	4.00	CF	19.00	CF	9.50	CF	16.12	CF	9.50	CF	CF	CF	4.88	CF	4.56	9.00	214 lbs.
		mm	102	CF	483	CF	241	CF	409	CF	241	CF	CF	CF	124	CF	116	229	97.1 kg.

Notes:

- Using a welded connection for more than one end fitting on an MP Series valve may complicate maintenance. Provisions must be made to allow removal of end fittings and body from the line.
- Double angle port are not full-port design.
- A gear operator is recommended for 3" and 4" valves. Consult PBM.
- Drawings are for illustration purposes only. Consult PBM prior to any fabrication or installation work.
- Approximate weights are for 3-way, side entry, angle port MP Series 4 valves, with female NPT end fittings.
- Q- and U- ends not available in 4" size.
- Approximate weight of 4" valve is with 150# R.F. Flange end fittings.

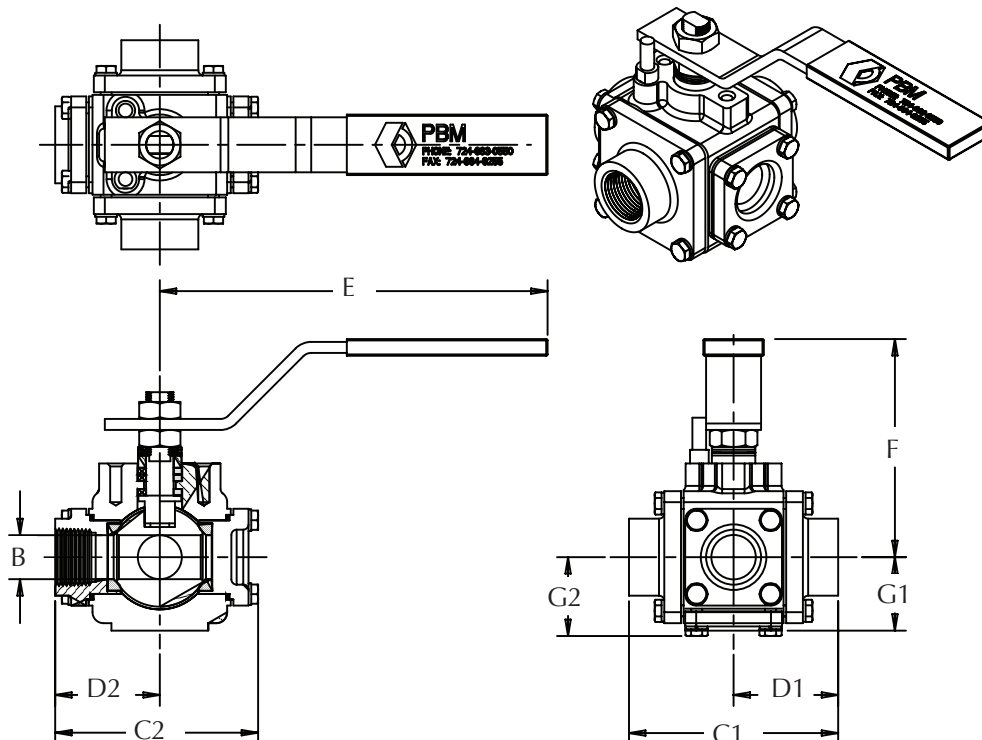

MP Series 5 Actuated

TFM™ OR VTFE SEAT MATERIAL												
Size	Actuator Type	Air supply		A		B		C		D		E
		psig	barg	inches	mm	inches	mm	inches	mm	inches	mm	NPT
1/2" DN 15	Double Acting	80	5.5	4.45	113	2.8	71	6.88	175	1.61	41	1/8
	Double Acting	60	4.1	4.45	113	2.8	71	6.88	175	1.61	41	1/8
	Spring Return	80	5.5	8.27	210	3.72	94	7.59	193	2.07	53	1/8
	Spring Return	60	4.1	9.47	241	4.17	106	8.14	207	2.3	58	1/8
3/4" DN 20	Double Acting	80	5.5	4.45	113	2.8	71	6.88	175	1.61	41	1/8
	Double Acting	60	4.1	4.45	113	2.8	71	6.88	175	1.61	41	1/8
	Spring Return	80	5.5	8.27	210	3.72	94	7.59	193	2.07	53	1/8
	Spring Return	60	4.1	9.47	241	4.17	106	8.14	207	2.3	58	1/8
1" DN 25	Double Acting	60, 80	4.1, 5.5	8.27	210	3.72	94	9.00	229	2.07	53	1/8
	Spring Return	80	5.5	10.83	275	4.84	123	10.0	254	2.68	68	1/4
	Spring Return	60	4.1	13.11	333	5.39	137	11.4	290	2.87	73	1/4
1-1/2" DN 40	Double Acting	60, 80	4.1, 5.5	13.11	333	5.39	137	13.58	345	2.87	73	1/4
	Spring Return	80	5.5	14.65	372	5.83	148	14.06	357	3.15	80	1/4
	Spring Return	60	4.1	17.13	435	6.46	164	14.95	380	3.44	87	1/4
2" DN 50	Double Acting	60, 80	4.1, 5.5	13.11	333	5.39	137	14.00	356	2.87	73	1/4
	Spring Return	80	5.5	14.65	372	5.83	148	14.50	368	3.15	80	1/4
	Spring Return	60	4.1	17.13	435	6.46	164	15.38	391	3.44	87	1/4
3" DN 80	Double Acting	80	5.5	13.11	333	5.39	137	15.67	398	2.87	73	1/4
	Double Acting	60	4.1	14.65	372	5.83	148	14.50	368	3.15	80	1/4
	Spring Return	80	5.5	19.69	500	7.36	187	18.00	457	3.9	99	1/4
	Spring Return	60	4.1	22.78	579	8.58	218	20.25	514	4.29	109	1/4
4" DN 100	Double Acting	60, 80	4.1, 5.5	22.78	579	8.58	218	22.25	565	4.29	109	1/4
	Spring Return	80	5.5	22.78	579	8.58	218	22.25	565	4.29	109	1/4
	Spring Return	60	4.1	26.46	672	11.42	290	27.00	686	5.71	145	1/4

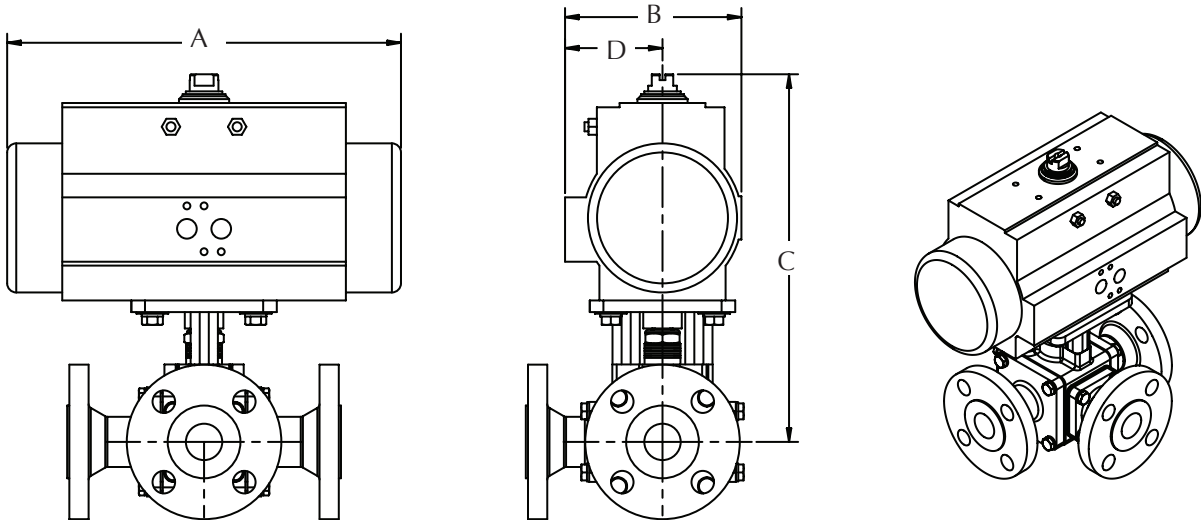

MP Series 4

A	Size	Units	B	C ₁		D ₁		C ₂		D ₂		E	F	G ₁	G ₂	H	I	Approx. Weight S/S
				Face to Face		℄ to Face		Face to Face		℄ to Face								
				Q/U-B-	L-	Q/U-B-	L-	Q/U-B-	L-	Q/U-B-	L-							
1/2" DN 15	C	inches	0.50	4.52	CF	2.26	CF	4.48	CF	2.30	CF	6.09	3.79	1.59	CF	0.87	3.50	7 lbs.
		mm	13	115	CF	57	CF	114	CF	58	CF	155	71.00	40	CF	22	89	3.2 kg.
3/4" DN 20	D	inches	0.75	4.52	CF	2.26	CF	4.48	CF	2.30	CF	6.09	3.79	1.59	CF	1.08	3.88	7 lbs.
		mm	19	115	CF	57	CF	114	CF	58	CF	155	71.00	40	CF	27	99	3.2 kg.
1" DN 25	E	inches	1.00	4.68	7.25	2.34	3.62	4.65	5.93	2.30	3.62	8.06	5.16	1.69	2.34	1.34	4.25	12 lbs.
		mm	25	119	184	59	92	118	151	58	92	205	131	43	59	34	108	5.4 kg.
1-1/4" DN 32	F	inches	1.25	4.68	CF	2.34	CF	4.65	CF	2.30	CF	8.06	5.16	1.69	2.34	1.69	4.63	12 lbs.
		mm	32	119	CF	59	CF	118	CF	58	CF	205	131	43	59	43	118	5.4 kg.
1-1/2" DN 40	G	inches	1.50	6.58	10.58	3.29	5.29	6.58	8.56	3.30	5.29	12.06	5.63	2.34	3.29	1.93	5.00	31 lbs.
		mm	38	167	269	84	134	167	217	84	134	306	143	59	84	49	127	14.1 kg.
2" DN 50	H	inches	2.00	7.92	11.94	3.96	5.97	7.70	9.71	3.90	5.97	12.06	6.02	2.72	3.96	2.42	6.00	47 lbs.
		mm	51	201	303	101	152	196	247	99	152	306	153	69	101	61	152	21.3 kg.
3" DN 80	K	inches	3.00	11.66	16.48	5.83	8.24	11.08	13.49	5.80	8.24	Consult PBM		3.90	5.83	3.55	7.50	133 lbs.
		mm	76	296	419	148	209	281	343	147	209	Consult PBM		99	148	90	191	60.3 kg.
4" DN 100	L	inches	4.00	15.44	19.36	7.72	9.63	14.23	16.14	7.70	9.63	Consult PBM		4.84	7.72	4.56	9.00	254 lbs.
		mm	102	392	492	196	245	361	410	196	245	Consult PBM		123	196	116	229	115.2 kg.
6" DN 150	M	inches	6.00		22.00		11.00		18.04		11.00	Consult PBM		6.81	10.00		11.00	400 lbs.
		mm	152		559		279		458		279	Consult PBM		173	254		279	181.4 kg.

NOTES:

- Using a welded connection for more than one end fitting on an MP Series valve may complicate maintenance. Provisions must be made to allow removal of end fittings and body from the line.
- Cavity fillers in 1/2" – 4" sizes are installed from the top. Cavity fillers in 6" size are installed from the sides.
- 1-1/4" and double angle port are not full-port design.
- A gear operator is recommended for 3", 4", and 6" valves. Consult PBM.
- Drawings are for illustration purposes only. Consult PBM prior to any fabrication or installation work.
- Approximate weights are for 3-way, side entry, angle port MP Series 4 valves, with female NPT end fittings.
- Q and U ends not available in 6" size.

Refer to Page 12-13 for Flow Pattern Options

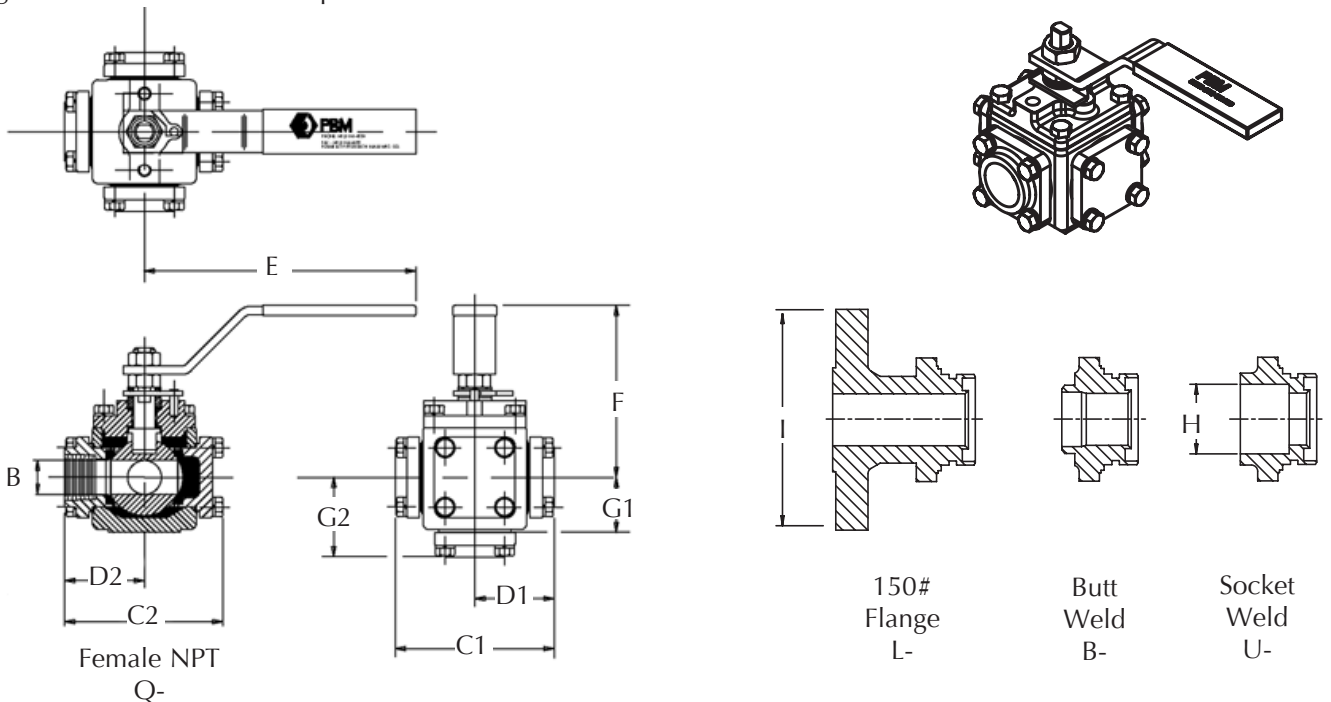

MP Series 4 Actuated

TFM™ OR VTFE SEAT MATERIAL												
Size	Actuator Type	Air supply		A		B		C		D		E
		psig	barg	inches	mm	inches	mm	inches	mm	inches	mm	NPT
1/2" DN 15	Double Acting	80	5.5	5.55	141	2.8	71	7.38	187	1.61	41	1/8
	Double Acting	60	4.1	6.46	164	3.17	81	7.38	187	1.77	45	1/8
	Spring Return	80	5.5	8.27	210	3.72	94	8.09	205	2.07	53	1/8
	Spring Return	60	4.1	9.47	241	4.17	106	8.64	219	2.30	58	1/8
3/4" DN 20	Double Acting	80	5.5	5.55	141	2.8	71	7.38	187	1.61	41	1/8
	Double Acting	60	4.1	6.46	164	3.17	81	7.38	187	1.77	45	1/8
	Spring Return	80	5.5	8.27	210	3.72	94	8.09	205	2.07	53	1/8
	Spring Return	60	4.1	9.47	241	4.17	106	8.64	219	2.30	58	1/8
1" DN 25	Double Acting	60, 80	4.1, 5.5	8.27	210	3.72	94	8.92	227	2.07	53	1/8
	Spring Return	80	5.5	10.83	275	4.84	123	9.97	253	2.68	68	1/4
	Spring Return	60	4.1	13.11	333	5.39	137	11.33	288	2.87	73	1/4
1-1/4" DN 32	Double Acting	60, 80	4.1, 5.5	8.27	210	3.72	94	8.92	227	2.07	53	1/8
	Spring Return	80	5.5	10.83	275	4.84	123	9.97	253	2.68	68	1/4
	Spring Return	60	4.1	13.11	333	5.39	137	11.33	288	2.87	73	1/4
1-1/2" DN 40	Double Acting	60, 80	4.1, 5.5	13.11	333	5.39	137	12.64	321	2.87	73	1/4
	Spring Return	80	5.5	14.65	372	5.83	148	13.12	333	3.15	80	1/4
	Spring Return	60	4.1	17.13	435	6.46	164	14.01	356	3.44	87	1/4
2" DN 50	Double Acting	60, 80	4.1, 5.5	13.11	333	5.39	137	13.04	331	2.87	73	1/4
	Spring Return	80	5.5	14.65	372	5.83	148	13.52	343	3.15	80	1/4
	Spring Return	60	4.1	17.13	435	6.46	164	14.41	366	3.44	87	1/4
3" DN 80	Double Acting	80	5.5	13.11	333	5.39	137	16.90	429	2.87	73	1/4
	Double Acting	60	4.1	14.65	372	5.83	148	17.38	441	3.15	80	1/4
	Spring Return	80	5.5	19.69	500	7.36	187	19.21	488	3.94	100	1/4
4" DN 100	Spring Return	60	4.1	22.78	579	8.58	218	21.46	545	4.29	109	1/4
	Double Acting	60, 80	4.1, 5.5	22.78	579	8.58	218	22.79	579	4.29	109	1/4
	Spring Return	80	5.5	22.78	579	8.58	218	22.79	579	4.29	109	1/4
6" DN 150	Spring Return	60	4.1	26.46	672	11.42	290	27.55	700	5.71	145	1/4
	Double Acting	80	5.5	22.78	579	8.58	218	24.19	614	4.29	109	1/4
	Double Acting	60	4.1	22.78	579	8.58	218	24.19	614	4.29	109	1/4
	Spring Return	80	5.5	26.46	672	11.42	290	24.19	614	5.71	145	1/4
Spring Return	60	4.1	26.46	672	11.42	290	28.95	735	5.71	145	1/4	

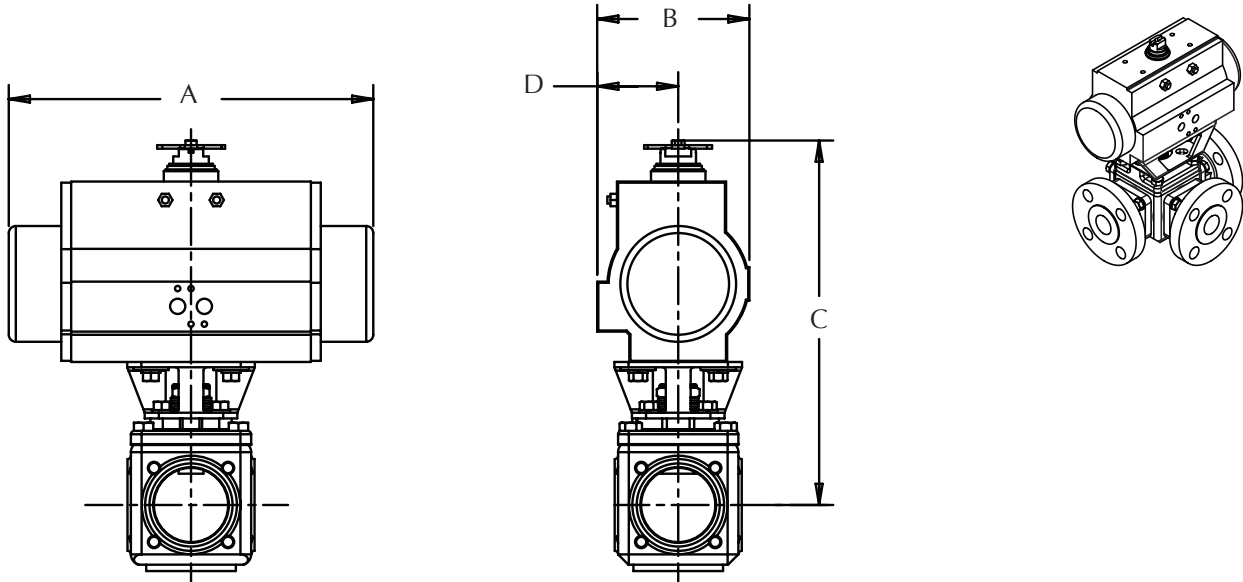

MP Series 1

Size	Size Code	Units	B Port Dia.	C ₁		D ₁		C ₂		D ₂		E Handle Length from ϕ	F ϕ to Top of Handle	G ₁ ϕ to Bottom Side Entry	G ₂ ϕ to Bottom Bottom Entry	H Sil-Braze	I 150# Flange	Approx. Weight Bronze NPT*
				Face to Face		ϕ to Face		Face to Face		ϕ to Face								
				Q-/S	L-	Q-/S	L-	Q-/S	L-	Q-/S	L-							
1/2" DN 15	C	inches	0.62	4.02	CF	2.01	CF	3.90	CF	2.01	CF	6.09	3.83	1.35	CF	0.93	3.50	8.8 lbs.
		mm	16	102	CF	51	CF	99	CF	51	CF	155	97	34	CF	24	89	7.7 kg.
3/4" DN 20	D	inches	0.75	4.02	CF	2.01	CF	3.90	CF	2.01	CF	6.09	3.83	1.35	CF	1.05	3.88	8.8 lbs.
		mm	19	102	CF	51	CF	99	CF	51	CF	155	97	34	CF	27	99	7.7 kg.
1" DN 25	E	inches	1.00	4.68	7.24	2.34	3.62	4.65	5.78	2.34	3.62	8.06	5.00	1.62	2.34	1.31	4.25	12 lbs.
		mm	25	119	184	59	92	118	145	59	92	205	127	41	59	33	108	10.0 kg.
1-1/4" DN 32	F	inches	1.25	4.68	CF	2.34	CF	4.65	CF	2.34	CF	8.06	5.00	1.62	2.44	1.67	4.62	12 lbs.
		mm	32	119	CF	59	CF	118	CF	59	CF	205	127	41	62	42	117	10.4 kg.
1-1/2" DN 40	G	inches	1.50	6.58	10.58	3.29	5.29	5.97	8.55	3.29	5.29	12.06	5.61	2.34	3.29	1.91	5.00	33 lbs.
		mm	38	167	269	84	134	152	218	84	134	306	142	59	84	49	127	21.3 kg.
2" DN 50	H	inches	2.00	7.75	11.94	3.87	5.97	7.76	9.76	3.87	5.97	12.06	5.75	2.75	3.87	2.38	6.00	49 lbs.
		mm	51	197	303	98	152	197	246	98	152	306	146	70	98	60	152	31.8 kg.
3" DN 80	K	inches	2.30	11.06	14.57	5.53	7.29	9.61	11.42	5.53	7.29	12.06	6.80	4.08	5.53	3.51	7.50	68 lbs.
		mm	58	281	370	140	185	244	290	140	185	306	173	104	140	89	191	48.5 kg.
4" DN 100	L	inches	3.00	CF	17.00	CF	8.50	CF	14.00	CF	8.50	14.06	8.82	5.56	CF	CF	9.00	235 lbs.
		mm	76	CF	432	CF	216	CF	356	CF	216	357	224	141	CF	CF	229	107 kg.

Notes:

1. Iron valves have raised face flanges. Bronze valves have flat face flanges.
2. Drawings are for illustration purposes only. Consult PBM prior to any fabrication or installation work.
3. Using a brazed or soldered connection for more than one end fitting on an MP Series valve may complicate maintenance. Provisions must be made to allow removal of end fittings and body from line.
4. Approximate weights are estimated based on valves with NPT end fittings except 4" valves with 150# Flanged end fittings..

Refer to Page 12-13 for Flow Pattern Options

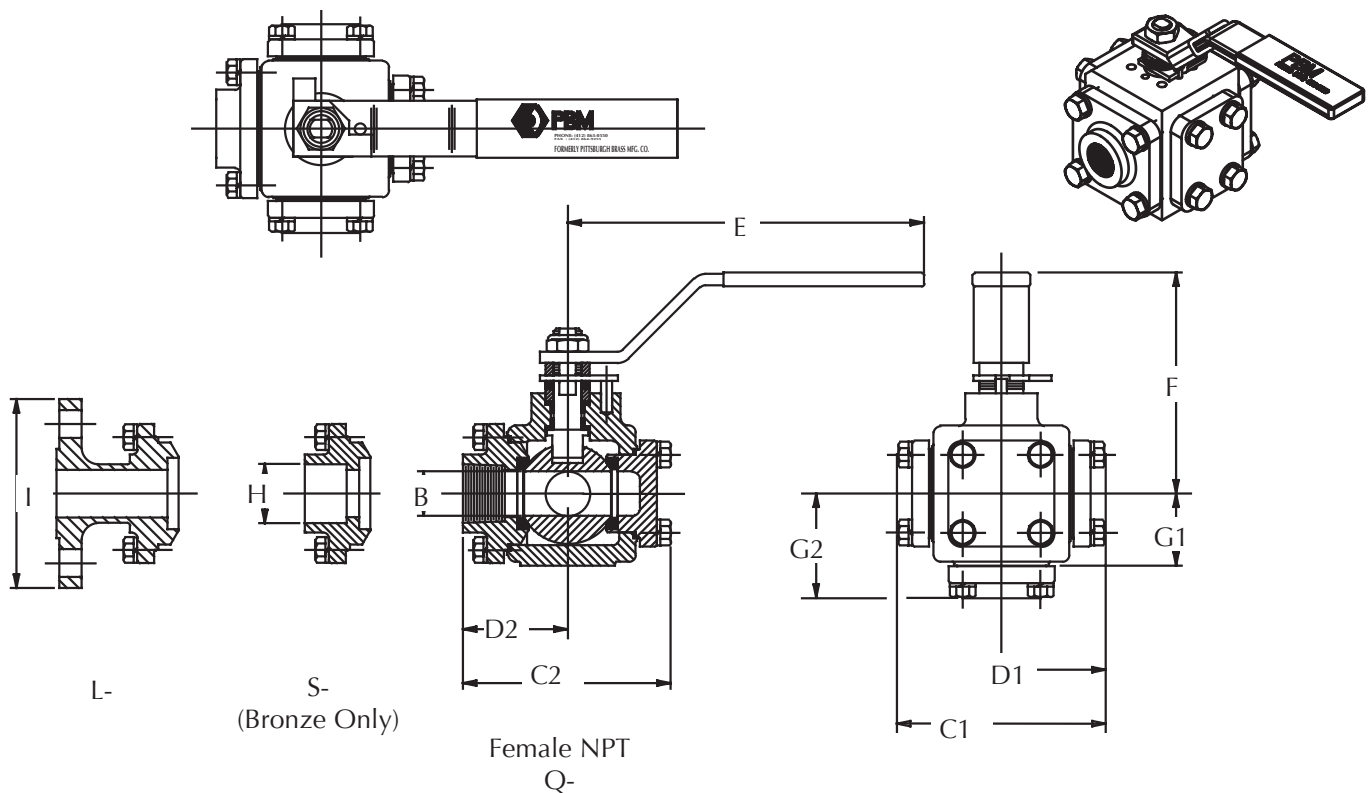

MP Series 1 Actuated

RTFE OR UHMWPE SEAT MATERIAL												
Size	Actuator Type	Air Supply		A		B		C		D		E
		psig	barg	inches	mm	inches	mm	inches	mm	inches	mm	NPT
1/2" DN 15	Double Acting	80	5.5	5.55	141	2.80	71	8.09	205	1.61	41	1/8
	Double Acting	60	4.1	6.46	164	3.17	81	8.09	205	1.77	45	1/8
	Spring Return	80	5.5	8.27	210	3.72	94	9.35	237	2.07	53	1/8
	Spring Return	60	4.1	9.47	241	4.17	106	9.35	237	2.30	58	1/8
3/4" DN 20	Double Acting	80	5.5	5.55	141	2.80	71	8.09	205	1.61	41	1/8
	Double Acting	60	4.1	6.46	164	3.17	81	8.09	205	1.77	45	1/8
	Spring Return	80	5.5	8.27	210	3.72	94	9.35	237	2.07	53	1/8
	Spring Return	60	4.1	9.47	241	4.17	106	9.35	237	2.30	58	1/8
1" DN 25	Double Acting	60, 80	4.1, 5.5	8.27	210	3.72	94	9.74	247	2.07	53	1/8
	Spring Return	80	5.5	10.83	275	4.84	123	12.15	309	2.68	68	1/4
	Spring Return	60	4.1	13.11	333	5.39	137	12.15	309	2.87	73	1/4
1-1/4" DN 32	Double Acting	60, 80	4.1, 5.5	8.27	210	3.72	94	9.74	247	2.07	53	1/8
	Spring Return	80	5.5	10.83	275	4.84	123	12.15	309	2.68	68	1/4
	Spring Return	60	4.1	13.11	333	5.39	137	12.15	309	2.87	73	1/4
1-1/2" DN 40	Double Acting	80	5.5	13.11	333	5.39	137	13.82	351	2.87	73	1/4
	Double Acting	60	4.1	13.11	333	5.39	137	13.82	351	2.87	73	1/4
	Spring Return	80	5.5	14.65	372	5.83	148	14.30	363	3.15	80	1/4
	Spring Return	60	4.1	17.15	436	6.46	164	15.19	386	3.44	87	1/4
2" DN 50	Double Acting	60, 80	4.1, 5.5	13.11	333	5.39	137	14.07	357	2.87	73	1/4
	Spring Return	80	5.5	14.65	372	5.83	148	15.44	392	3.15	80	1/4
	Spring Return	60	4.1	17.15	436	6.46	164	16.38	416	3.44	87	1/4
3" DN 80	Double Acting	60, 80	4.1, 5.5	13.11	333	5.39	137	14.42	366	2.87	73	1/4
	Spring Return	60, 80	4.1, 5.5	19.69	500	7.36	187	16.73	425	3.94	100	1/4
4" DN 100	Double Acting	60, 80	4.1, 5.5	13.11	333	5.39	137	17.57	446	2.87	73	1/4
	Spring Return	80	4.1, 5.5	19.69	500	7.36	187	19.88	505	3.94	100	1/4
	Spring Return	60	4.1, 5.5	19.69	500	7.36	187	22.13	562	3.94	100	1/4

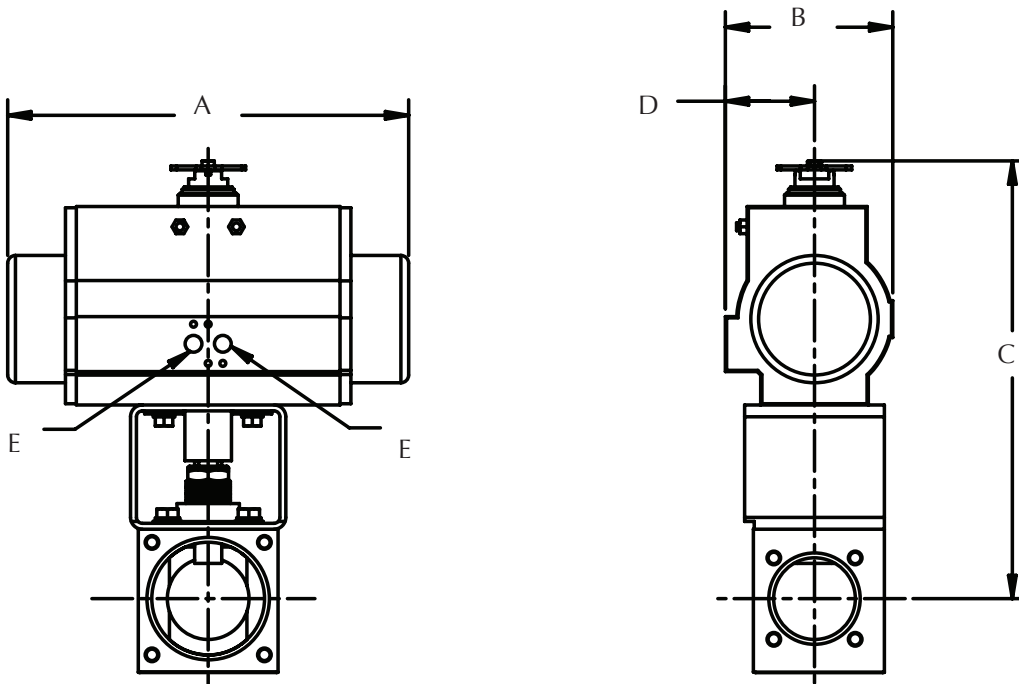

Instrument Valves

PBM's instrument valve is used for process isolation or isolation of pressure gauges, orifice plates, flush rings and various measurement instruments. Valves are designed to ASME B16.34. They offer a higher performance solution to needle valves.

SIZES

- 1/2" and 3/4" sizes with 0.41 bore

PRESSURE CLASS

- 1/4" - 3/4" Up To ANSI CL2500 (CL1500 standard)

MATERIALS

- Stainless Steel
- Duplex Stainless Steel
- Carbon Steels
- Monel®
- Hastelloys®
- Others Available

END CONNECTIONS

- Thread Pipe, male or female
- Flanged
- Buttweld (tube or pipe)
- Socket Weld (male or female)
- Compression
- Instrument Adapter Flange
- Others Available

FEATURES

- Quarter Turn Operation
- Optional Extended Handle with lock out
- Bleed or Gauge Ports Available
- Soft and Metal Seated Designs
- Locking Handle Standard
- Welded Body
- API-622 Low-E Stem Packing Standard
- Rodable in 1/4" - 3/4"
- SIL-3 Capable per IEC 61508



SEATING

- TFM™ Seats - 350°F, 176°C
- S-TEF® Seats - 400°F, 204°C
- PEEK® Seats - 500°F, 260°C
- Stellite® Ball & Seats, 800°F, 427°C
- Tungsten or Chrome Carbide Coated S/S Ball & Seats, < 800°F, 427°C

Notes:

PBM can comply with API-6D if specified.

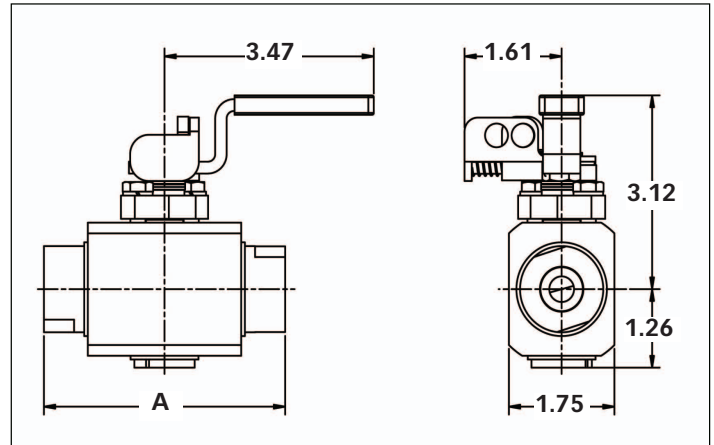

2-WAY VALVE End Fitting	A inches	A mm
Ext. Male NPT	6.50	165
Male NPT	4.75	121
Female NPT	4.00	102
Ext. Female Socket Weld	6.50	165
Buttweld for Sch. 40 Pipe	6.50	165
Buttweld for Tube	6.50	165

Notes:

Dimensions shown for 1/2" valves only.
Design is rodable with rod out tool.

PACKING

- Die molded Graphite (High Temperature) TFM™ or S-TEF®
- API-622 Low-E Stem Packing Standard in 1/2" and 3/4" sizes with .41 bore. It is optional in larger sizes.

TESTING AND DOCUMENTATION

- MTR (Material Test Reports)
- PMI (Positive Material Identification)
- LP (Liquid penetrant)
- Radiographic examination
- Pressure testing per API 598
- Magnetic particle examination
- Ultrasonic examination

PBM's New Style Instrument Valves are Tested & Proven to the API 622 Standard

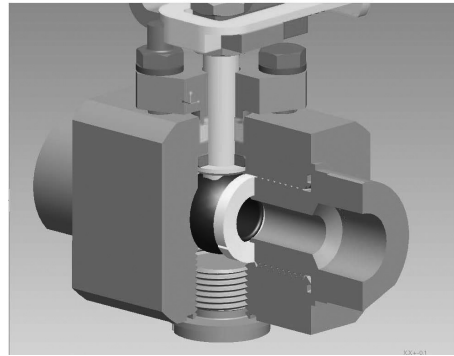

What makes PBM valves API 622?

PBM's Instrument (IM) new style valves standardize on a product offering with API 622 packing which certifies PBM valves for low emission technology.

The API 622 packing features:

- Average stem packing leakage ≤ 10 ppmv for the duration of the test (100 ppm allowable)
- API-607 fire tested
- Successfully passed API-622 testing, test report available upon request.

Double Block & Bleed Valves



**1/2" CL1500
DOUBLE BLOCK AND
BLEED VALVE**
with compression
ends and
locking lever
handles

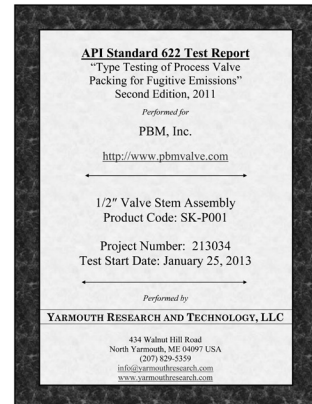

DBB VALVE End Fitting	A in.	A mm	B in.	B mm
Extended Male NPT	8.25	210	4.13	105
Male NPT	6.50	165	3.25	83
Female NPT	5.75	146	2.88	73
Ext. Female Socket Weld	8.25	210	4.13	105
Buttweld for Sch. 40 Pipe	8.25	210	4.13	105
Buttweld for Tube	8.25	210	4.13	105

Notes:
Dimensions shown for 1/2" valves only.
Design is rodable with rod out tool.

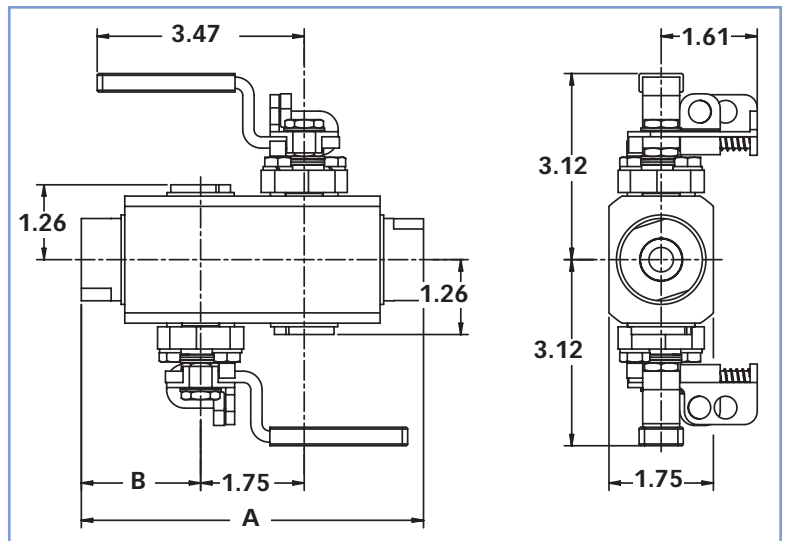

Bolted Instrument Valves

PBM's bolted Instrument Valve design allows end connection design and fabrication flexibility. It is available in a wide range of materials for a variety of temperature and pressure classes to meet your most stringent process applications.

FEATURES

- Full and Reduced Port Designs
- Customizable End Connections
- Quarter Turn Operation
- Bleed or Gauge Ports Available
- Bolted Body
- API-607 Fire Rated
- Braided Graphite Packing
- API-622 Low-E Stem Packing Standard
- Gear Operator recommended for 1-1/2" and above.

SIZES

- 1/2" - 2" CL600, CL900 and CL1500

SEATING

- TFM™ Seats: 350°F (176°C)
- S-TEF® Seats: 400°F (204°C)
- PEEK® Seats: 500°F (260°C)
- Stellite® Ball & Seats: 800°F (427°C)
- Tungsten or Chrome Carbide Coated S/S Ball & Seats: 800°F (427°C)

Size	Ends	Units	A		D		E		F		G		H					
			Overall Length		CL to Bottom of Valve (2-Way)		Distance to Top of Valve		Body Width without Ends		Handle Radius		CL to Locking Mechanism					
			CL600	CL1500	CL600	CL1500	CL600	CL1500	CL600	CL1500	CL600	CL1500	CL600	CL1500				
1/2" DN 15	Flanged	in (mm)	6.5 (165)	8.5 (216)	1.72 (44)	5.2 (132)	2.4 (61)	3.47 (88)	1.61 (41)									
	Female NPT	in (mm)	4.75 (121)															
	Others	in (mm)	8.5 (216)															
3/4" DN 20	Flanged	in (mm)	7.5 (191)	9 (229)	2.33 (59)	3.96 (101)	3.75 (95)	5 (127)	2.08 (53)									
	Female NPT	in (mm)	5.5 (140)															
	Others	in (mm)	9 (229)															
1" DN 25	Flanged	in (mm)	8.5 (216)	10 (254)	2.92 (74)	5.2 (132)	4.5 (114)	8.81 (224)	2.57 (65)									
	Female NPT	in (mm)	6 (152)															
	Others	in (mm)	10 (254)															
1-1/2" DN 40	Flanged	in (mm)	9.5 (241)	12 (305)	2.82 (72)	4.17 (106)	5.76 (146)	7.18 (182)	5.38 (137)	7.5 (191)	11.8 (300)	12 (305)	N/A					
	Female NPT	in (mm)	6.5 (165)	7.5 (191)														
	Others	in (mm)	12 (305)															
2" DN 50	Flanged	in (mm)	11.5 (292)	14.5 (368)	3.42 (87)	4.82 (122)	6.13 (156)	7.43 (189)	6.25 (159)	8 (203)	11.8 (300)	12 (305)						
	Female NPT	in (mm)	8 (203)	10 (254)														
	Others	in (mm)	14.5 (368)															

The high temperature valve version consists of carbide coating on the ball and seats.

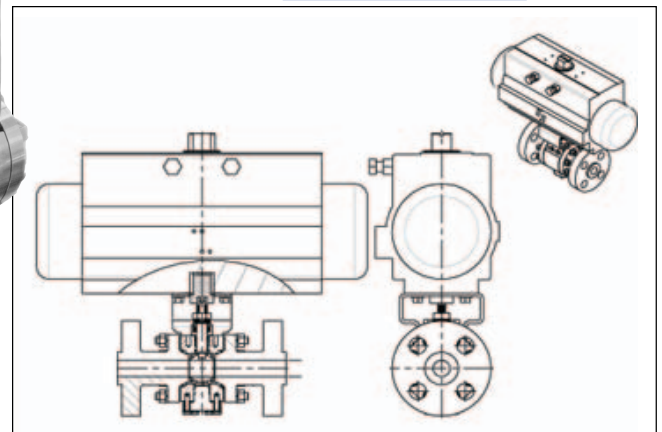
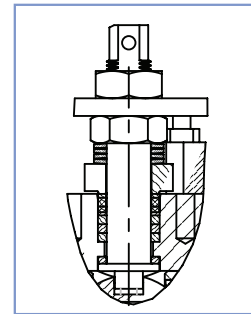
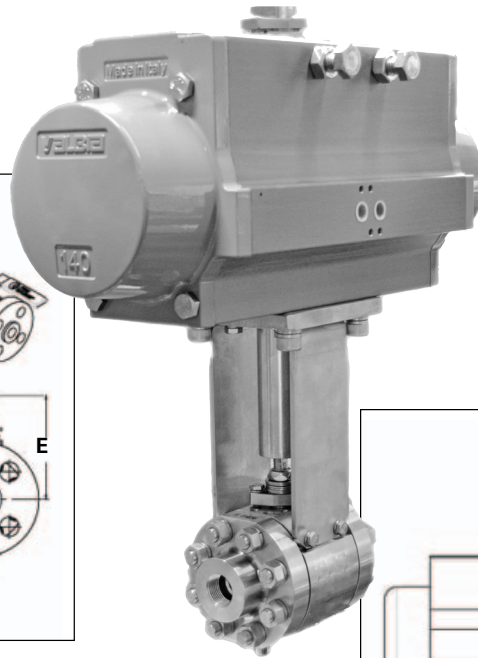
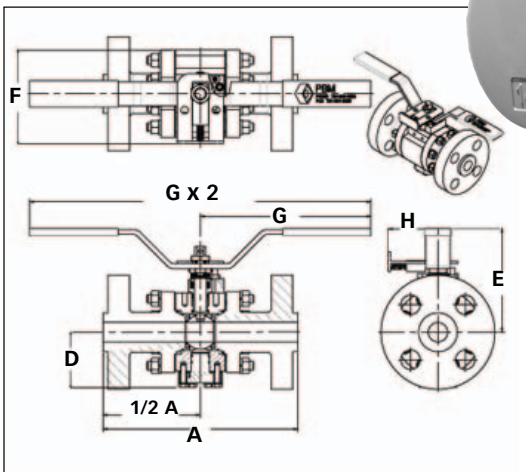

Bolted Double Block & Bleed Valves

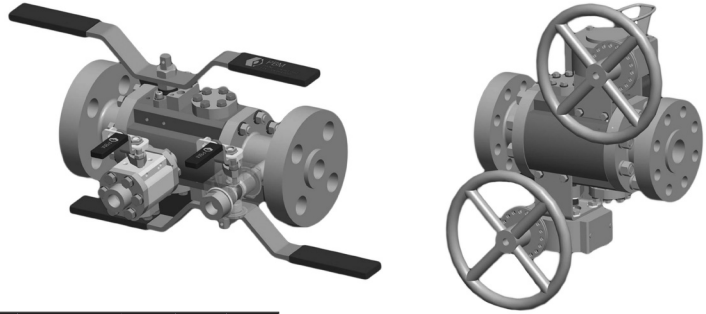
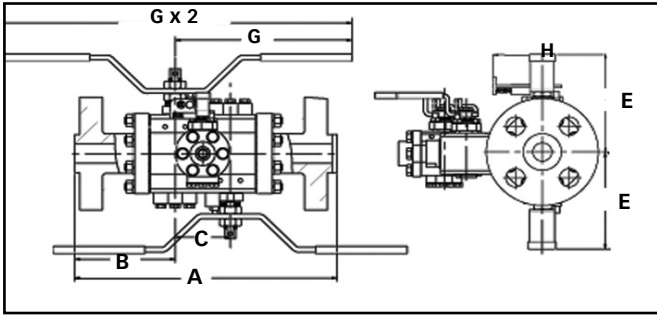

Size	Ends	Units	A		B		C		E		F		G		H	
			Overall Length		C to End		Ball Separation		Distance to Top of Valve		Body Width without Ends		Handle Radius		C to Locking Mechanism	
			CL600	CL1500	CL600	CL1500	CL600	CL1500	CL600	CL1500	CL600	CL1500	CL600	CL1500	CL600	CL1500
1/2" DN 15	Flanged	in (mm)	8.25 (210)	10.25 (260)	3.25 (83)	4.25 (108)	1.75 (44)		5.2 (132)		2.4 (61)		3.47 (88)		1.61 (41)	
	Female NPT	in (mm)	6.5 (165)		2.375 (60)											
	Others	in (mm)	10.25 (260)		4.25 (108)											
3/4" DN 20	Flanged	in (mm)	9.75 (248)	11.25 (286)	3.75 (95)	4.5 (114)	2.25 (57)		3.96 (101)		3.75 (95)		5 (127)		2.08 (53)	
	Female NPT	in (mm)	7.75 (197)		2.75 (70)											
	Others	in (mm)	11.25 (286)		4.5 (114)											
1" DN 25	Flanged	in (mm)	11.25 (286)	12.75 (324)	4.25 (108)	5 (127)	2.75 (70)		5.2 (132)		4.5 (114)		8.81 (224)		2.57 (65)	
	Female NPT	in (mm)	8.75 (222)		3 (76)											
	Others	in (mm)	12.75 (324)		5 (127)											
1-1/2" DN 40	Flanged	in (mm)	13.25 (337)	15.75 (400)	4.75 (121)	6 (152)	3.75 (95)		5.76 (146)	7.18 (182)	6 (152)	7.5 (191)	12 (305)		N/A	
	Female NPT	in (mm)	10.25 (260)		3.25 (83)											
	Others	in (mm)	15.75 (400)		6 (152)											
2" DN 50	Flanged	in (mm)	15.25 (387)	18.5 (470)	5.75 (146)	7.25 (184)	3.75 (95)	4 (102)	6.13 (156)	7.43 (189)	6.75 (171)	8 (203)	12 (305)			
	Female NPT	in (mm)	11.75 (298)		4 (102)											
	Others	in (mm)	18.5 (470)		7.25 (184)											

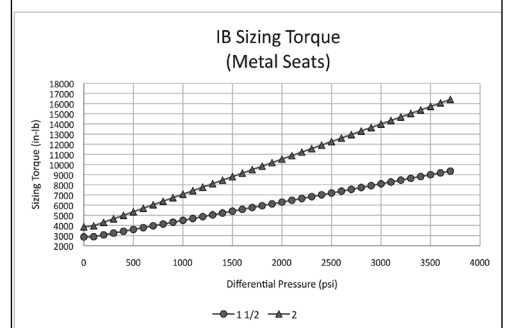
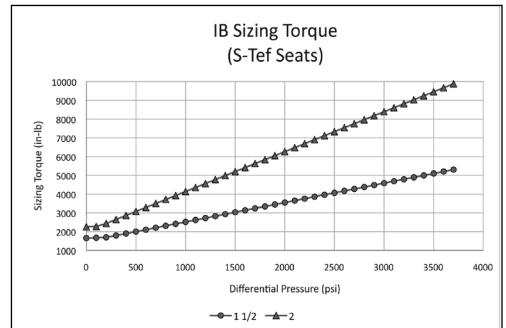
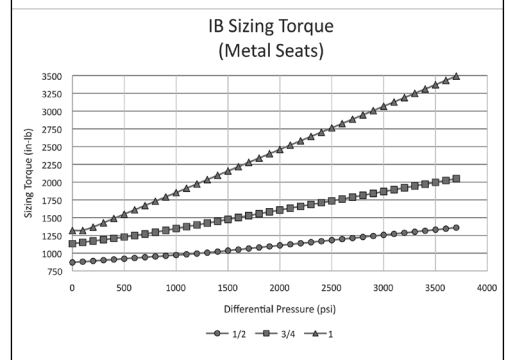
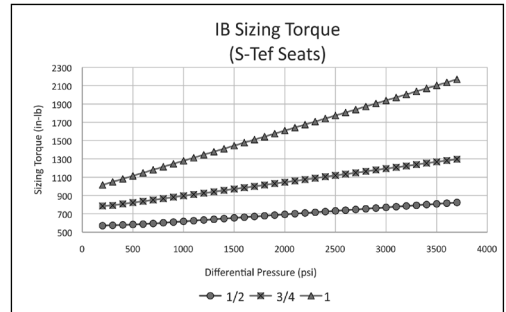

BOLTED INSTRUMENT VALVES PRESSURE/TEMPERATURE AND TORQUE CHARTS

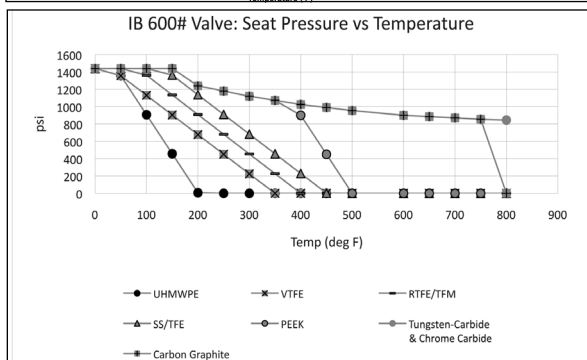
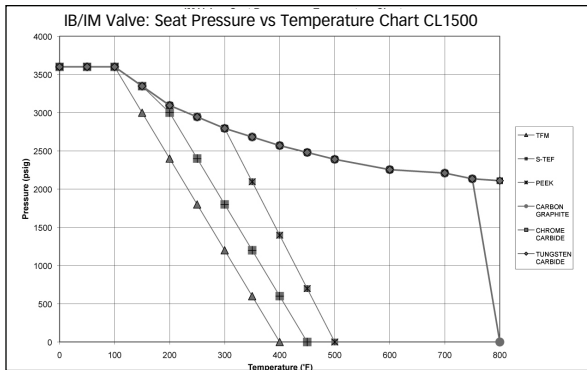

Fabflex® Instrumentation Valve Manifolds

PBM's Valve Manifolds have temperatures that range from 300° to 600° F, 149 to 316°C with pressures from 150 to 400 psig, 10 to 28 barg. A refinery uses these manifolds for measuring as well as level indication.

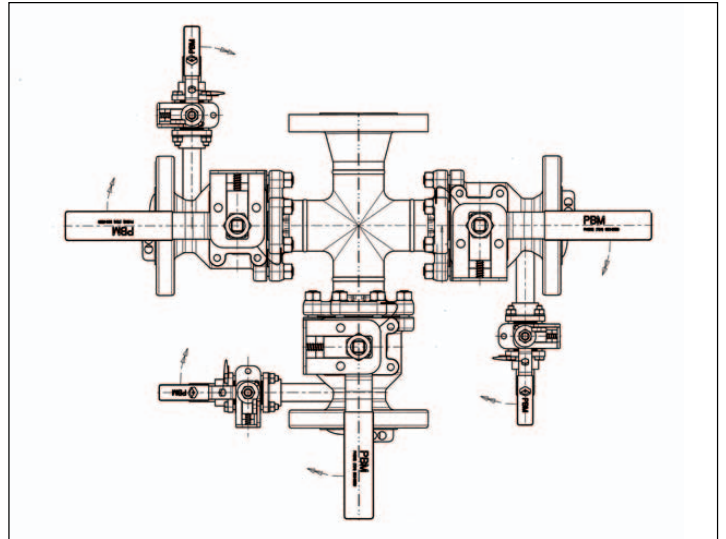
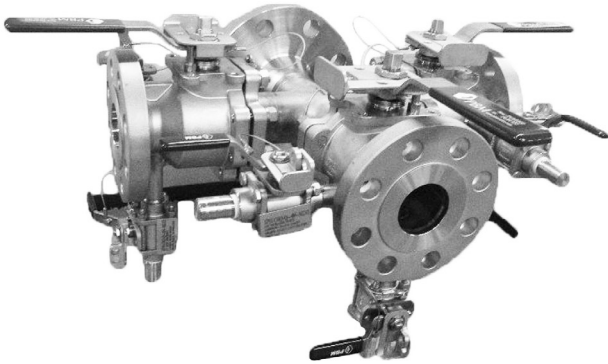

Fabflex® Fabricated Manifold Solution:

- Custom PBM Fabflex® manifold design for multiple instrumentation mounts.
- Custom manifold design to optimize space utilization.
- Factory fabricated in a controlled manufacturing environment to ensure high quality welding fabrication process.
- Individual valves fabricated "into" the manifold eliminating many emission leak paths to improve the overall EPA rating of the system.
- Field installation simplified into bolting up one flange and installing the transmitters, transducers or other instrumentation.





Flush Rings/Bleed Rings with Integral Valve

Flush rings and Bleed rings to customer material and pressure class specifications designed to fit between standard flanges using conventional flange gaskets. Integral ball valve allows venting purging, sampling and instrument isolation.

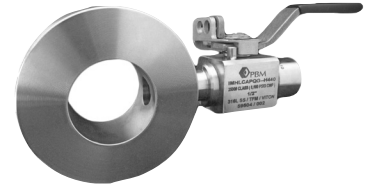

Sizes:

- 2" width standard

Consult PBM for additional sizes.

Materials:

- Stainless Steel
- Duplex
- Hastelloy®
- Others

Features:

- Integral code-welded valve for flushing purging and instrument isolation.

1 & 2	3&4	5	6	7	8	9	10
PRODUCT	MATERIAL	SIZE	SERIES	FLUSH RING CLASS	NO & LOCATION PURGE/BLEED PORTS	PURGE/ BLEED PORT SIZE	PURGE/BLEED PORT TYPE
FR = Flush Ring	H = 316 Stainless Steel	C = 1/2"	6 = Firesafe API-607	H = CL900 (RF - Inside Ring)	- = None	- = None	- = None
	HL = 316 Stainless Steel	D = 3/4"		J = CL1500 (RF - Inside Ring)	A = 1 Purge / Bleed Port	A = 1/4 inch	Q = FNPT
	E = A-105 Carbon Steel	E = 1"		K = CL2500 (RF - Inside Ring)	B = 2 Purge / Bleed Ports 90° Apart	C = 1/2 inch	U = Socket Weld
	C = Hastelloy C-276	F = 1-1/4"		L = CL150 (RF - Inside Ring)	C = 2 Purge / Bleed Ports 180° Apart	D = 3/4 inch	
	Y = Hastelloy C-22	G = 1-1/2"		M = CL300 (RF - Inside Ring)		E = 1 inch	
	P = AL6XN	H = 2"		N = CL600 (RF - Inside Ring)			
	W = Nickel 200	J = 2-1/2"		R = CL150 (RF - Full Ring)			
	HC = Alloy 20	K = 3"		S = CL300 (RF - Full Ring)			
	22 = Duplex 2205	L = 4"		T = CL600 (RF - Full Ring)			
	N = 922 Bronze	M = 6"		U = CL900 (RF - Full Ring)			
				W = CL1500 (RF - Full Ring)			
				X = CL2500 (RF - Full Ring)			
				N = 8"			
P = 10"							
	Q = 12"						
	R = 14"						

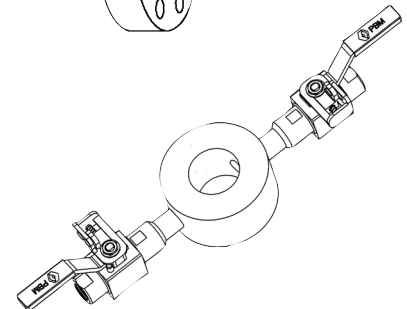
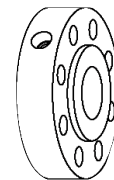

Sampling Tank Bottom Valves

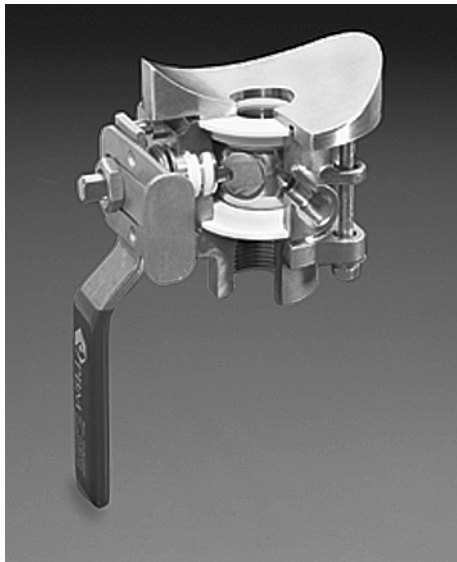

Sample process media quickly and easily with PBM's Sampling Valve. Special pad design minimizes dead space. Easy CIP with Purge Ports and Milled Ball Flats ensures reliable samples. Valve can be shipped pre-mounted to piping for easy installation. Ideal for heavy duty and sanitary applications. Manual valves standard.

Sizes:

- 1/2" - 2"

Materials:

- 316 & 316L S/S
- Hastelloy®
- Titanium
- Others

Options:

- Actuation
- Steam
- Polishing

Cryogenic Ball Valves

PBM Cryogenic valves have a unique design that provides superior performance through cooling and heating cycles. The valves meet leakage criteria per MSS SP-134. Fire tested to API-607 Rev. 6. "CN" series split body ANSI flanged Cryogenic valves are also available.

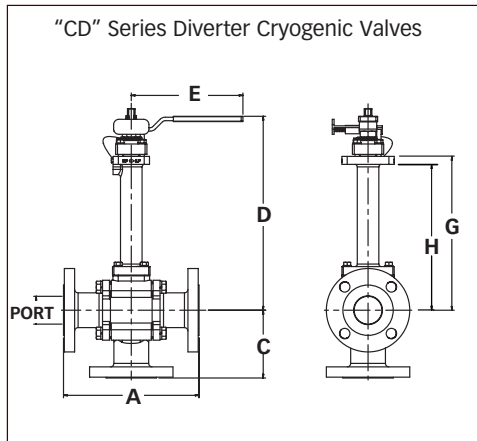
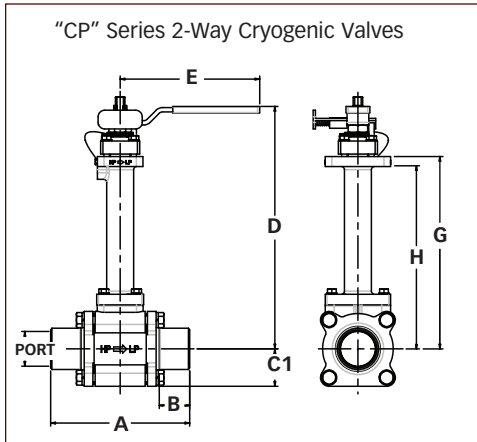

- Sizes 1/2" - 4" Consult PBM for additional sizes.
- Temperatures from 400° F, 205° C down to -320° F, -200° C
- **Live-loaded** stem packings
- Fire safe to API 607 Rev. 6
- Designed & Tested in accordance with ASME B31.1 and B16.34.
- Materials of construction: stainless steel, other materials available.
- Pressures to 720 psi CWP (ANSI CL300)
- Cleaned for oxygen service
- Quarter turn operation
- Locking lever handle or optional oval locking handwheel
- Automation available
- TFM™ seats/graphite seals
- Internal and external grinding
- Uni-directional flow and vented ball
- Valve meets or exceeds leakage performance per MSS SP-134
- Optional API-622 Low-e Packing (cannot be lox cleaned)



Dimensions

SIZE			UNIT	BALL PORT	BUTT WELD		EXTENDED SOCKET WELD		150# Flange		300# Flange		FNPT		CI	D HANDLE HEIGHT STD. EXT. BONNET	E	G CL to TOP OF BONNET	H CL to BOTTOM OF BONNET	TORQUE			
US	DIN	ISO		A	B	A	Socket Depth	A	C	A	C	A	C	UNIT						at 70° F	at -320° F	ACT. SIZING	
1/2"	8, 10, 15	8, 10	inches	0.50	5.50	1.50	6.32	0.41	5.50	2.75	5.75	2.88	3.12	1.56	1.00	9.92	4.15	7.78	7.46	IN-LBS	45	95	143
			mm	12.70	139.70	38.10	160.53	10.41	139.70	69.85	146.05	73.03	79.25	39.62	25.40	251.97	105.41	32.29	189.48	N-m	5	11	16
3/4"	20	15, 20	inches	0.75	5.50	1.50	6.56	0.53	5.75	2.88	6.00	3.00	3.44	1.72	1.00	9.92	4.15	7.78	7.46	IN-LBS	45	95	143
			mm	19.05	139.70	38.10	166.62	13.46	146.05	73.03	152.40	76.20	87.38	43.69	25.40	251.97	105.41	197.61	189.48	N-m	5	11	16
1"	25, 32	25	inches	1.00	6.00	1.50	7.06	0.53	6.50	3.25	6.75	3.38	4.25	2.13	1.33	9.91	5.09	7.64	7.22	IN-LBS	80	155	233
			mm	25.40	152.40	38.10	179.32	13.46	165.10	82.55	171.45	85.85	107.95	54.10	33.78	251.71	129.29	194.06	183.39	N-m	9	18	27
1-1/2"	40	32, 40	inches	1.50	7.50	1.50	8.56	0.53	8.00	4.00	8.25	4.13	5.50	2.75	1.78	13.60	8.03	10.76	10.18	IN-LBS	300	420	630
			mm	38.10	190.50	38.10	217.42	13.46	203.20	101.60	209.55	104.78	139.70	69.85	45.21	345.44	203.96	273.30	258.57	N-m	34	48	72
2"	50	50	inches	2.00	8.00	1.75	9.32	0.66	9.75	4.88	10.00	5.00	6.00	3.00	2.15	13.95	8.03	11.07	10.49	IN-LBS	480	840	1260
			mm	50.80	203.20	44.45	236.73	16.76	247.65	123.83	254.00	127.00	152.40	76.20	54.61	354.33	203.96	281.18	266.45	N-m	55	96	144
3"	80	80	inches	3.00	13.50	2.31	14.88	0.69	12.75	6.38	13.25	6.63	9.00	4.50	3.14	17.37	12.06	13.41	12.83	IN-LBS	660	1320	1980
			mm	76.20	342.90	58.67	377.95	17.53	323.85	161.93	336.55	168.28	228.60	114.30	79.76	441.20	306.32	340.61	325.88	N-m	75	151	226
4"	80	80	inches	4.00	16.00	2.31	17.62	.81	15.00	7.50	16.00	8.00	12.00	6.00	4.91	n/a	n/a	14.83	12.83	IN-LBS	720	4500	6750
			mm	101.6	406.4	58.67	447.55	20.57	381.0	190.5	406.4	203.2	304.8	152.4	124.71	n/a	n/a	376.68	325.88	N-m	81	508	763

Note: Only butt weld ends apply to DIN and ISO valves

Torque Ratings for PBM Actuators

Spring Return Actuators

Double Acting Actuators

Actuator Model	Air pressure at actuator (psig)	
	60 psig	80 psig
	Constant Torque Output (in-lbs)	
PAVCL453D -- 0052	133	179
PAVCL453D -- 0063	238	321
PAVCL453D -- 0075	435	586
PAVCL453D -- 0085	629	851
PAVCL453D -- 0100	991	1,336
PAVCL453D -- 0115	1,640	2,210
PAVCL453D -- 0125	2,157	2,906
PAVCL453D -- 0140	3,013	4,018
PAVCL453D -- 0160	4,394	5,859
PAVCL453D -- 0200	8,239	10,981
PAVCL453D -- 0270	19,097	25,469

All published torque values are guaranteed minimum values.

Actuator Model	Spring Set	Spring Torque Output		Air Pressure at Actuator (psig)			
		(in-lbs)		60		80	
		Start	End	Start	End	Start	End
PAVCL253S -- 0052	03	66	46	80	47	N/A	N/A
PAVCL453S -- 0052	05	105	72	N/A	N/A	101	55
PAVCL253S -- 0063	03	128	71	149	79	N/A	N/A
PAVCL453S -- 0063	05	196	111	N/A	N/A	193	95
PAVCL253S -- 0075	03	249	133	275	137	N/A	N/A
PAVCL453S -- 0075	05	380	205	N/A	N/A	354	157
PAVCL253S -- 0085	03	361	215	387	211	N/A	N/A
PAVCL453S -- 0085	05	536	321	N/A	N/A	503	257
PAVCL253S -- 0100	03	564	318	628	329	N/A	N/A
PAVCL453S -- 0100	05	860	489	N/A	N/A	802	378
PAVCL253S -- 0115	03	957	538	1,044	541	N/A	N/A
PAVCL453S -- 0115	05	1,432	800	N/A	N/A	1,352	637
PAVCL253S -- 0125	03	1,313	718	1,351	640	N/A	N/A
PAVCL453S -- 0125	05	1,913	1,055	N/A	N/A	1,762	789
PAVCL253S -- 0140	03	1,958	1,036	1,910	856	N/A	N/A
PAVCL453S -- 0140	05	2,728	1,453	N/A	N/A	2,481	1,017
PAVCL253S -- 0160	04	2,841	1,770	2,447	1,350	N/A	N/A
PAVCL453S -- 0160	05	3,327	2,230	N/A	N/A	3,452	2,240
PAVCL253S -- 0200	04	4,699	3,124	4,788	3,080	N/A	N/A
PAVCL453S -- 0200	06	6,867	4,664	N/A	N/A	5,893	3,539
PAVCL253S -- 0270	05	12,549	8,044	11,495	6,884	N/A	N/A
PAVCL453S -- 0270	08	16,735	10,735	N/A	N/A	15,360	9,220

Weights and Volumes

Actuator Model	Rotate CCW	Rotate CW	PAVC series
	Volume (cu.in.)	Volume (cu.in.)	Approx. wgt (lbs)
PAVCL453D -- 0052	6.1	7.9	2.47
PAVCL453S -- 0052	6.1	6.7	2.87
PAVCL453D -- 0063	12	14	3.66
PAVCL453S -- 0063	12	11.6	4.35
PAVCL453D -- 0075	22	27	6.13
PAVCL453S -- 0075	22	22	7.48
PAVCL453D -- 0085	31	39	8.60
PAVCL453S -- 0085	31	32	10.60
PAVCL453D -- 0100	48	61	12.13
PAVCL453S -- 0100	48	49	15.44
PAVCL453D -- 0115	79	104	19.51
PAVCL453S -- 0115	79	84	25.25
PAVCL453D -- 0125	99	135	23.81
PAVCL453S -- 0125	99	109	31.04
PAVCL453D -- 0140	138	193	35.94
PAVCL453S -- 0140	138	146	48.06
PAVCL453D -- 0160	220	306	47.95
PAVCL453S -- 0160	220	215	65.04
PAVCL453D -- 0200	348	644	81.57
PAVCL453S -- 0200	348	463	121.26
PAVCL453D -- 0270	915	1,086	182.23
PAVCL453S -- 0270	915	946	221.06



Use PBM's 2-Way Control Valves in industrial and sanitary throttling or shearing applications to accurately control the flow of liquids or thick media. These valves feature characterized balls with various port shapes, including "V." Manual valve standard.

Control Valves

Sizes:

- 1/2" - 6"

Materials:

- 316 & 316L S/S
- Hastelloy®
- Others

Options:

- Actuation
- 30°, 45°, 60° V Angle (Others Available)
- Slotted
- Locking Handle
- Polishing & Electropolishing
- Automation

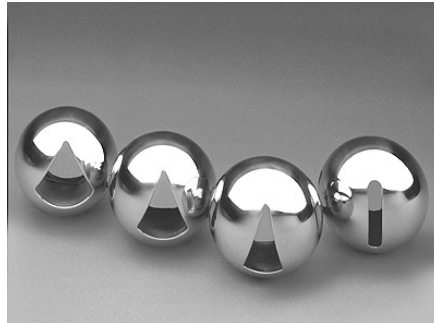

Positioners

- Gauges/No gauges
- 4-20 mA (Electro-pneumatic)
- 3-15 psi (pneumatic)
- Weatherproof, explosion proof
- Proximity, Mechanical Switches
- Solid State Sensors
- Flat or Domed Indicator



Electric Actuators

- Weatherproof, explosion proof
- Modulating or On/Off
- 2, 3, or 4 position
- Battery back-up
- Communication Bus interfaces available
- Auxiliary Limit Switches
- Motor Brake
- Handwheel override
- Potentiometers
- AC or DC

Solenoids

Features:

- Compact pool valve with threaded port direct mounts to actuator.
- All exhaust ports are pipeable, providing better protection against harsh environments.
- Standard manual override
- DIN, weatherproof and explosion proof solenoids available
- Single and dual coil solenoid constructions
- Mountable in any position

Position Indicators



Options:

- Weatherproof, Explosion proof
- Mechanical or Proximity Switches
- Fieldbus
- DeviceNet
- Visual Indication
- AS-i
- ATEX, IEC, CSA, NEMA, etc.





WORLDWIDE REPRESENTATION

United States • Canada • Australia • Mexico • Brazil • Argentina • Chile • UAE • United Kingdom • Sweden
Central Europe • Germany • Spain • Belgium • France • Ireland • Switzerland • Austria • The Netherlands
South Africa • India • Taiwan • China • Thailand • Singapore • Saudi Arabia • Malaysia • South Korea



www.PBMValve.com

Visit PBM Valve online to find the PBM domestic or international representative near you.

