

MAINTENANCE INSTRUCTIONS



3-Way Clean Steam Diverter Ball Valves

DC Series 8 & 9

1/2" - 6" Prepared for Actuation

COMPONENT LIST	
Item	Description
A	Body
B	Ball
C	End Fitting
F	Stem
G	Follower
H	Seat
H ₂	Metal Encapsulated Ring
I	Stem Packing
J ₁	Large Spring Washer
J ₂	Small Spring Washer
L ₁	Large O-ring
L ₂	Small O-ring
M	End Fitting Fastener
N	Jam Nut
O	Gasket
S	Hex Nut
T	Cavity Filler
Y ₁	Internal Ground Spring
Y ₂	External Ground Spring
Y ₃	External Ground Wire
Z	Tag

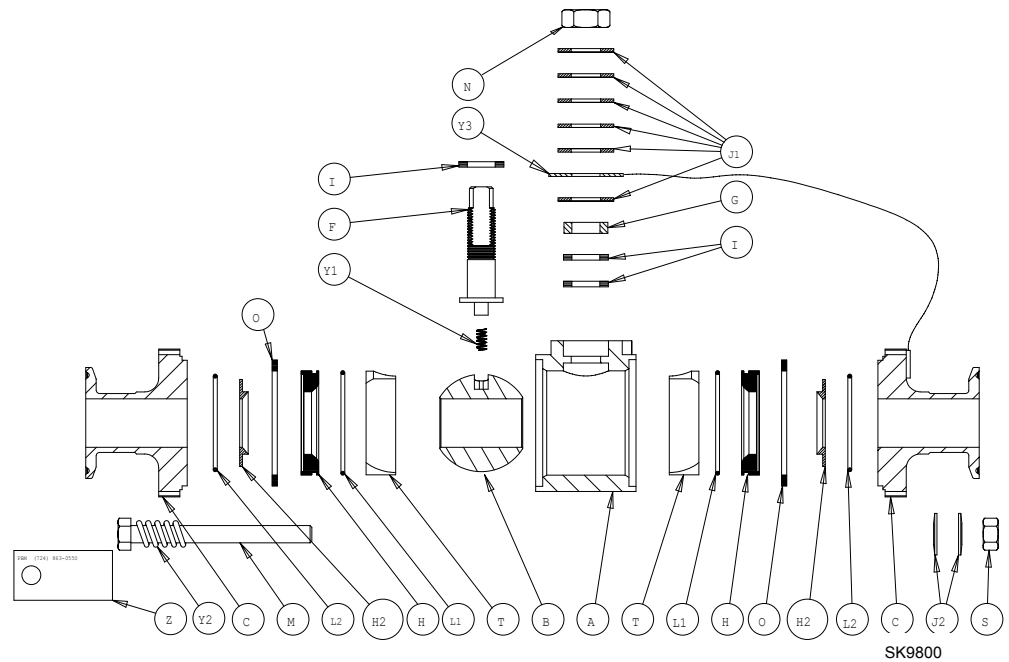

Follow instructions to ensure optimum performance:

Adjusting for Normal Wear

- PBM Ball Valves are designed with the Adjust-O-Seal[®] feature. If the valve shows signs of leakage due to normal seat wear, tighten the end fitting fasteners evenly, in the staggered sequence shown in Table 2, until leakage stops and the valve operates smoothly:
 - Initially, there should be a space between end fittings and the body. This space is key to the Adjust-O-Seal feature and allows in-line adjustment of the seats and gaskets.
 - End fitting fasteners should be tightened only until the valve stem breakaway torque is reached (Table 1).
- If valve shows signs of leakage in stem area due to normal stem packing wear, tighten the jam nut as follows:
 - For valves 2-inches and smaller, tighten the nut to completely compress the spring washers, and then loosen nut 1/8th turn.
 - For valves larger than 2-inches, tighten the nut until a gap of about 0.05-inches exists between the adjacent spring washers.

Leakage should stop, and the valve should continue to operate smoothly.
- After adjustments have been made to seats, or if packing leakage cannot be stopped, a repair kit will be required.

Installing Replacement Parts

- Isolate and depressurize the associated piping system. Remove insulation, if any.
- Remove all air and electrical power from the actuator, solenoid valve, and switch box, if any.
- Remove the actuator, coupling insert, solenoid valve, and switch box, if any.
- For valves with welded end connections, the valve can be disassembled with the body subassembly swung out from the end fittings, or it can be disassembled with the body subassembly completely removed from the end fittings.
 - To swing out the body subassembly from the end fittings:
 - Disconnect piping from the body nozzle.
 - Loosen the hex nuts on the end fitting fasteners.
 - Remove the fasteners, nuts, and spring washers between the body swing out ring and the stem.
 - Spring the connecting piping 1/8" to remove the compression on the body from the end fittings.
 - Swing the body out from the end fittings until the body completely clears the end fittings. The body's swing out ring will rotate about its fastener.
 - The sprung piping can now be returned to its original compression, if desired.
 - To remove the entire body subassembly from the piping:

- Disconnect piping from the body nozzle.
 - Loosen all end fitting fasteners. Then, remove the fasteners, including the nuts and spring washers, between the body swing out ring and the stem. Remove the fastener, including tag, nut, spring washers, and external ground spring, if any, that passes through the body swing out ring.
 - Spring the connecting piping 1/8" to remove the compression on the body from the end fittings.
 - Slide the body subassembly out from between the end fittings.
 - The sprung piping can now be returned to its original compression, if desired.
- If the entire valve is to be removed disconnect piping from the end connections and the body nozzle then remove the valve and loosen and remove the valve's body fasteners.
 - Remove the seats, metal encapsulated rings, gaskets, O-rings and cavity fillers, if any, from the body.
 - Turn the stem to position the flats on the stem perpendicular to the axis of the body. Slide the ball out of the body, taking care not to nick or scratch the ball.
 - Loosen and remove the jam nut from the stem. Remove the spring washers and follower. Remove the internal ground spring, if any, from under the stem.
 - Push the stem into the body and out an open end of the body. The bottom packing may come off with the stem. If not, reach into the body counterbore and remove.
 - Remove the top packings from the body.
 - Before reassembling the valve, examine the parts and repair or replace damaged or worn parts. Clean metal parts, as necessary, using a solvent compatible with the process fluid and a non-abrasive cloth. PBM recommends using new seats and seals at each assembly.
 - Place a new packing on the stem such that the packing seats on top of the ledge on the stem. This packing should be white in color.
 - Insert the stem into the body bore and through the stem bore in body.
 - Install the two additional packings over the stem. Push the packings into the body counter bore. The topmost packing should be gray in color.
 - Install the follower over the stem until it rests on the top packing.
 - Install a large spring washer concave side facing upward.
 - Install remaining large spring washers, alternating convex with concave curves and with the concave side of the top spring washer facing downward. Spring washers should not be "nested" (curving in same direction). Install the external ground wire terminal between two spring washers, if use of a ground wire is applicable.
 - Lubricate the stem threads with an anti-galling lubricant.
 - Thread a jam nut onto the stem. For valves 2-inches and smaller, tighten to completely compress the spring washers, and then back off 1/8th turn.

SK9800

- For valves larger than 2-inches, tighten until the gap between adjacent spring washers is about 0.05-inches.
20. Turn the stem to position the flats on the stem perpendicular to the axis of the body. Install the internal ground spring, if any, on the bottom of the stem.
 21. Insert the ball into the body. Slide the stem tang into the ball slot, careful not to nick or scratch the ball. The stem tang and ball slot are indexed such that the ball cannot be installed in an improper manner.
 22. Install cavity fillers, if any, into the body.
 23. Lubricate the O-rings and ½ inch of each end of the body bore with a lubricant compatible with the process fluid.
 24. Install the large O-rings onto the groove on the outer diameter of the seats and then carefully force the seats into the body bore until they contact the ball.
 25. Insert the metal seat encapsulating rings into the bores of the seats.
 26. Install the gaskets onto the body bore and install the small O-rings between the metal encapsulating rings and the gaskets.
 27. Lubricate the external threads of the body bolting with an anti-galling lubricant.
 28. For valves with end fittings welded into the piping, spring the end fittings outward and slide the body between them. Release spring force from the end fittings to allow the end fittings to enter the body, taking care not to cut the O-rings. Connect piping to the body nozzle.
 29. If the valve was completely removed from the piping, press the end fittings against the body. Connect piping to the body nozzle. Install bolts, external ground spring (if any) and external ground wire (if any), and tag. If the valve is electrically grounded, install the external ground spring around the bolt that passes through the swing out ring. This spring will ground the body to the end fitting. Install spring washers, concave sides facing each other on the fasteners.
 30. Install and hand-tighten hex nuts and position the ball in a full flow position (not mid-positioned).
 31. Wrench-tighten the bolting according to the procedure shown in Table 2, keeping an even gap between the body and end fittings, and until the stem torque, as shown in Table 1, is reached. The torque is the measured stem torque as the valve leaves the closed position. Cycle the valve to verify freedom of operation and torque.
 32. Re-install the valve in the piping, if applicable, and re-install the actuator and coupling insert and reconnect air and electrical power. Check to ensure the valve ball port indication on the top of the stem is in the proper position before installing the actuator.
 33. If practical, check the valve seats and seals for leaks.
 34. Insulate the valve, if applicable. Do not insulate the actuator or bracket.

TABLE 1: STEM TORQUE, TFM SEATS	
Valve Size	Valve Stem Breakaway Torque
	in-lbs.
½-inch	25 to 35
¾-inch	35 to 45
1-inch	50 to 66
1½-inch	140 to 170
2-inch	160 to 200
2-1/2-inch	260 to 310
3-inch	390 to 475
4-inch	610 to 750
6-inch	1,600 to 2,200

Notes for Table 1:

1. Torque values are measured at the stem, NOT at the body fasteners.

TABLE 2: TIGHTENING PROCEDURE FOR END FITTINGS
<ol style="list-style-type: none"> 1. Hand-tighten fasteners. 2. Wrench-tighten each fastener in the sequence illustrated until spring washers begin to compress. 3. Continue tightening bolts 1/8 turn in the sequence illustrated until recommended torque value (Table 1) is achieved when measuring at valve stem.

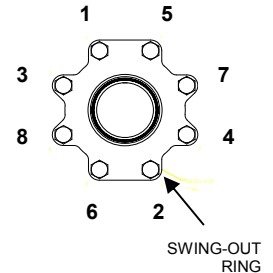
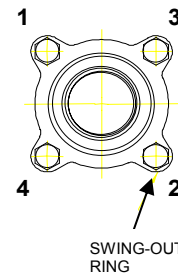

PBM, Inc., 1070 Sandy Hill Road, Irwin, PA 15642 USA
 Phone: (724) 863-0550 or (800) 967-4PBM
 Fax: (724) 864-9255
 E-mail: info@pbmvalve.com Web: www.pbmvalve.com
 LT-155B (DC Ser 8, 9) 10/06 Printed in USA

