

MAINTENANCE INSTRUCTIONS

2-Way Ball Valves

SM Series 5, 1/2" - 6"

Prepared for Actuation



COMPONENT LIST	
Item	Description
A	Body
B	Ball
C	End Fitting
F	Stem
G	Follower
H	Sea/Gasket*
I	Stem Packing
J	Large Spring Washer
M	End Fitting Fastener
N	Jam Nut
O	Gasket
S	Hex Nut
T	Cavity Filler
Y _i	Internal Ground Spring
Y _c	Coil Ground Spring
Y _e	External Ground Wire
Z	Tag

*SM Series has separate seat and body gasket.

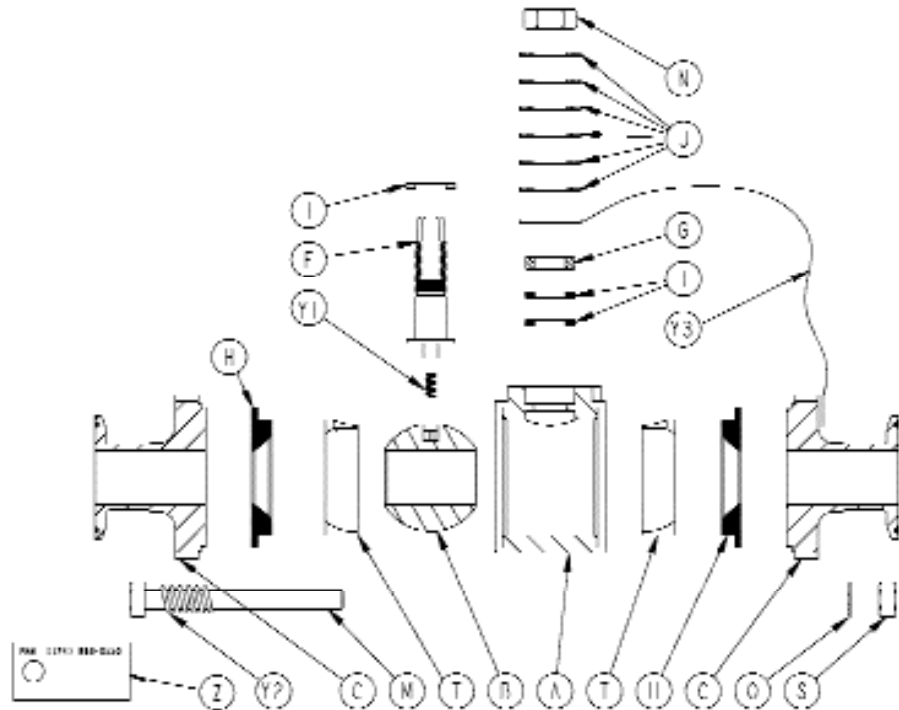

SK-98003

Follow instructions to ensure optimum performance:

Adjusting for Normal Wear

- PBM Ball Valves are designed with the Adjust-O-Seal® feature. If the valve shows signs of leakage due to normal seat wear, tighten the end fitting fasteners evenly, in the staggered sequence shown in Table 3, until leakage stops and the valve operates smoothly:
 - Initially, there should be a space between end fittings and the body. This space is key to the Adjust-O-Seal feature and allows in-line adjustment of the seats and gaskets.
 - End fitting fasteners should be tightened only until the valve stem breakaway torque is reached (Table 1).
- If valve shows signs of leakage in stem area due to normal stem packing wear, tighten the jam nut as follows:
 - For valves 2" and smaller, tighten the nut to completely compress the spring washers, then loosen nut 1/2 turn.
 - For valves 2 1/2" and larger, tighten the nut until a gap of about .05" exists between the adjacent spring washers.

Leakage should stop, and the valve should continue to operate smoothly.
- After adjustments have been made to seats, or if packing leakage cannot be stopped, a repair kit will be required.

Installing Replacement Parts

- Isolate and depressurize the associated piping system. Cycle the valve to depressurize and drain any trapped fluid from the body cavity. Remove insulation, if any.
- Remove all air and electrical power from the actuator, solenoid valve, and switch box, if any.
- Remove the actuator, solenoid valve, and switch box, if any.
- For valves with Tri-Clamp end connections:
 - Loosen and remove the clamps connecting the valve to the piping. Then, remove the valve and Tri-Clamp gaskets.
 - Loosen and remove the hex nuts and lock washers from the body/end fitting fasteners.
 - Pull the end fittings free from the body.
- For valves with welded end connections, the valve can be disassembled with the body subassembly swung out from the end fittings or it can be disassembled with the body subassembly completely removed from the end fittings.

- To swing out the body subassembly from the end fittings:
 - Open the valve.
 - Loosen the hex nuts on the body/end fitting fasteners.
 - Remove the fasteners, nuts, and lock washers between the body swing out ring and the stem.
 - Spring the connecting piping 1/8" to remove the compression on the body from the end fittings.
 - Swing the body out from the end fittings until the body completely clears the end fittings. The body's swing out ring will rotate about its fastener.
 - The sprung piping can now be returned to its original compression, if desired.
 - To remove the entire body subassembly from the piping:
 - Open the valve.
 - Loosen the hex nuts on the end fitting fasteners.
 - Remove the fasteners, nuts, and lock washers between the body swing out ring and the stem. Remove the fastener, including the nut and lock washer that passes through body swing out ring, tag, and external ground spring, if any.
 - Spring the connecting piping 1/8" to remove the compression on the body from the end fittings.
 - Slide the body subassembly out from between the end fittings.
 - The sprung piping can now be returned to its original compression, if desired.
- Remove the seats, gaskets, and cavity fillers, if any, from the body.
 - Turn the stem to close the ball. Slide the ball out of the body, taking care not to nick or scratch the ball.
 - Remove the internal ground spring, if any, from under the stem.
 - Loosen and remove the jam nut from the stem. Remove the spring washers and follower.
 - Push the stem into the body and out an open end of the body. The bottom packing may come off with the stem. If not, reach into the body counterbore and remove.
 - Remove the top packings from the body.
 - Before reassembling the valve, examine the parts and repair or replace damaged or worn parts. Clean metal parts, as necessary, using a solvent compatible with the process fluid and a non-abrasive cloth. PBM recommends using new seats and seals at each assembly.
 - Insert a new packing on the stem such that the packing seats on top of the ledge on the stem.

14. Insert the stem into body bore and through the stem bore in the body.
15. Install the remaining two packings over the stem. Push the packings into the body counterbore.
16. Install the follower over the stem until it rests on the top packing.
17. Install a spring washer concave side facing upward. Install the external ground wire terminal on top of this spring washer, if applicable.
18. Install the remaining spring washers, alternating convex with concave curves and with the concave side of top spring washer facing upward. Spring washers should not be "nested" (curving in the same direction).
19. Lubricate the stem threads with an anti-galling lubricant.
20. Thread a jam nut onto the stem. For valves 2" and smaller, tighten to completely compress the spring washers, then back off 3/4 turn. For valves 2 1/2" and larger, tighten until the gap between adjacent spring washers is about .05".
21. Position the stem to close the valve. Install the internal ground spring, if any, on the bottom of the stem.
22. Insert the ball into the body. Slide the stem tang into the ball slot, being careful not to nick or scratch the ball.
23. Rotate the stem until the ball is in the open position.
24. Install cavity fillers, if any, into the body.
25. Install seats and gaskets into the body.
26. Lubricate external threads of body bolting with anti-galling lubricant.

27. For valves with Tri-Clamp end fittings, install end fittings against body.
28. For valves with end fittings welded into the piping, with the valve open, spring the end fittings outward and slide the body between them. Release spring force from end fittings to allow end fittings to enter body.
29. Install fasteners, tagging, and lock washers. If the valve is electrically grounded, install the coil ground spring around the bolt that passes through the swing out ring. This spring should ground the ring to the end fitting.
30. Install and hand-tighten hex nuts. The external ground wire connected to the stem should have its terminal installed underneath one of the nuts and lock washers, if applicable. Then, close the valve.
31. Wrench-tighten the bolting according to the procedure shown in Table 3, keeping an even gap between the body and end fittings, and until the stem torque, as shown in Table 1, is reached. The torque is the measured stem torque as the valve leaves the closed position. Cycle the valve to verify freedom of operation and torque.
32. If the valve has Tri-Clamp end fittings, reinstall the valve into the piping using appropriate Tri-Clamp gaskets and clamps.
33. Install the actuator, solenoid valve, and switch box, if any, and reconnect air and electrical power.
34. If practical, check the valve seats and seals for leaks.
35. Insulate the valve, if applicable. Do not insulate the actuator or bracket.

Valve Size	Size Code	Valve Stem Breakaway Torque
		TF
1/2"	C5	32
3/4"	D5	40
1"	E5	58
1 1/2"	G5	156
2"	H5	180
2 1/2"	J5	288
3"	K5	384
4"	L5	792
6"	M5	1920

Valve Size	Repair Kits	Cavity Filler Kits*
	SM	SM
1/2"	SMTFC5--C--1	SPVTC5--D--3
3/4"	SMTFD5--C--1	SPVTD5--D--3
1"	SMTFE5--C--1	SPVTE5--D--3
1 1/2"	SMTFG5--C--1	SPVTG5--D--3
2"	SMTFH5--C--1	SPVTH5--D--3
2 1/2"	SMTFJ5--C--1	SPVTJ5--D--3
3"	SMTFK5--C--1	SPVTK5--D--3
4"	SMTFL5--C--1	SPVTL5--D--3
6"	SMTFM5--C--1	SPVTM5--D--3

Notes for Table 1:

1. Stem torque values shown are minimum values and represent ideal conditions (100 psig or less, ambient temperature, with fluid free of suspended solids and comparable in viscosity to water).
2. If valve has not been factory actuated by PBM, margin must be added appropriate to the actuator size.
3. Torque values are measured at the stem, NOT at the fasteners.
4. If PEEK or KYNAR material, contact PBM for correct torque values.

Material Definitions:

HT	S/STFE	Stainless Steel Reinforced Polytetrafluoroethylene
KY	KYNAR®	Polyvinylidene Fluoride
PK	PEEK	Polyetheretherketon
PL	PLUS	Glass & Carbon Reinforced Polytetrafluoroethylene
RT	RTFE	Glass Reinforced Polytetrafluoroethylene
TF	TFM®	Teflon, modified
UT	UHMWPE	Ultra High Molecular Weight Polyethylene
VT	VTFE	Virgin Polytetrafluoroethylene

Notes for Table 2:

1. Standard repair kits are TFM:
 - a. For VTFE, replace "TF" with "VT". Example: a 1" kit becomes SPVTE5--C--1.
 - b. For S/STFE, replace "TF" with "HT". Example: a 1" kit becomes SPHTE5--H--1.
 - c. For PLUS, replace "TF" with "PL". Example: a 1" kit becomes SPPLE5--E--1.
 - d. For PEEK, replace "TF" with "PK". Example: a 1" kit becomes SPPKE5--N--1.
 - e. For UHMWPE, replace "TF" with "UT". Example: a 1" kit becomes SPUTE5--K--1.
 - f. For KYNAR, replace "TF" with "KY". Example: a 1" kit becomes SPKYE5--R--1.

Note that if you are changing the seat and seal code in positions 3 and 4 of the part number (as shown above), you must also replace the letter designator in position 9 with the appropriate code from the Seat & Seal column in the PBM Part Number Manual (LT-PN98).

2. Repair kits include 2 seats and 3 packings.

*Cavity filler kits include 2 fillers.

Adjust-O-Seal® is a registered trademark of PBM, Inc.

Kynar® is a registered trademark of Elf Atochem North America Corporation.

<ol style="list-style-type: none"> 1. Hand-tighten fasteners. 2. Wrench-tighten each fastener in the sequence illustrated until lock washers begin to compress. 3. Continue tightening bolts 1/8 turn until recommended torque value (Table 1) is achieved when measuring at valve stem.

