

# MAINTENANCE INSTRUCTIONS

PBM Sanitary Check Valves  
[www.pbmvalve.com](http://www.pbmvalve.com)



## Vertical Check (VC)

### Disassembly

1. Loosen and remove the clamp, then pull the end fitting away from the body.
2. Remove the gasket and the poppet.

### Assembly

1. Place the poppet in the body with the concave side of the poppet facing upward (see illustration).
2. Place the gasket into the groove of the body.
3. Place the end fitting on the gasket, ensuring that it is seated properly on the gasket. In the case of the 1" vertical check valve, be certain to orient the end fitting such that the conical side of the fitting is towards the poppet.
4. Install and tighten the clamp wing nut to 25 in-lbs of torque.

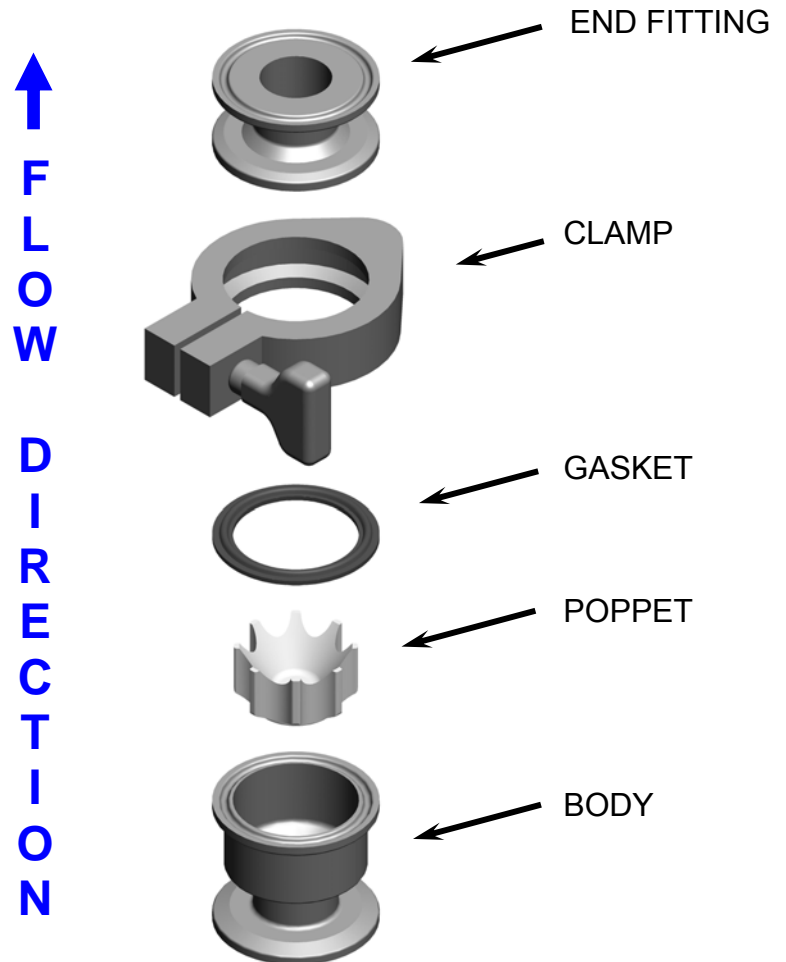

Follow instructions to ensure optimum performance.

Check Valve Replacement Parts (Vertical and Horizontal)

Size	Poppet	Poppet Material	Gasket	Gasket Material
1/2"	HVVTC002	virgin PTFE	HCXXC013	see below
3/4"	HVVTD002	virgin PTFE	HCXXD013	see below
1"	HVVTE002	virgin PTFE	HCXXE013	see below
1-1/2"	HVVVG002	virgin PTFE	HCXXG013	see below
2"	HVVTH002	virgin PTFE	HCXXH013	see below

Insert VI for Viton or ED for EPDM in the gasket part designation where **XX** is shown.

Note: PBM recommends that at least one set of replacement parts be available, or enough replacement parts for 10% of the valve population, whichever quantity is greater.

## Horizontal Check (HC)

### Disassembly

1. Loosen and remove the clamp, then pull the end fitting away from the body.
2. Remove the gasket and the poppet.

### Assembly

1. Place the poppet in the body with the concave side of the poppet facing towards the end fitting (see illustration).
2. Place the gasket into the groove of the body.
3. Place the end fitting on the gasket, ensuring that the marks on the body and end fitting are aligned, and that the end fitting is seated properly on the gasket (see illustration).
4. Install and tighten the clamp wing nut to 25 in-lbs of torque.
5. In order to provide proper drainage in operation, the horizontal check valve must be installed with the "TOP" marking facing directly upwards.

Follow instructions to ensure optimum performance.

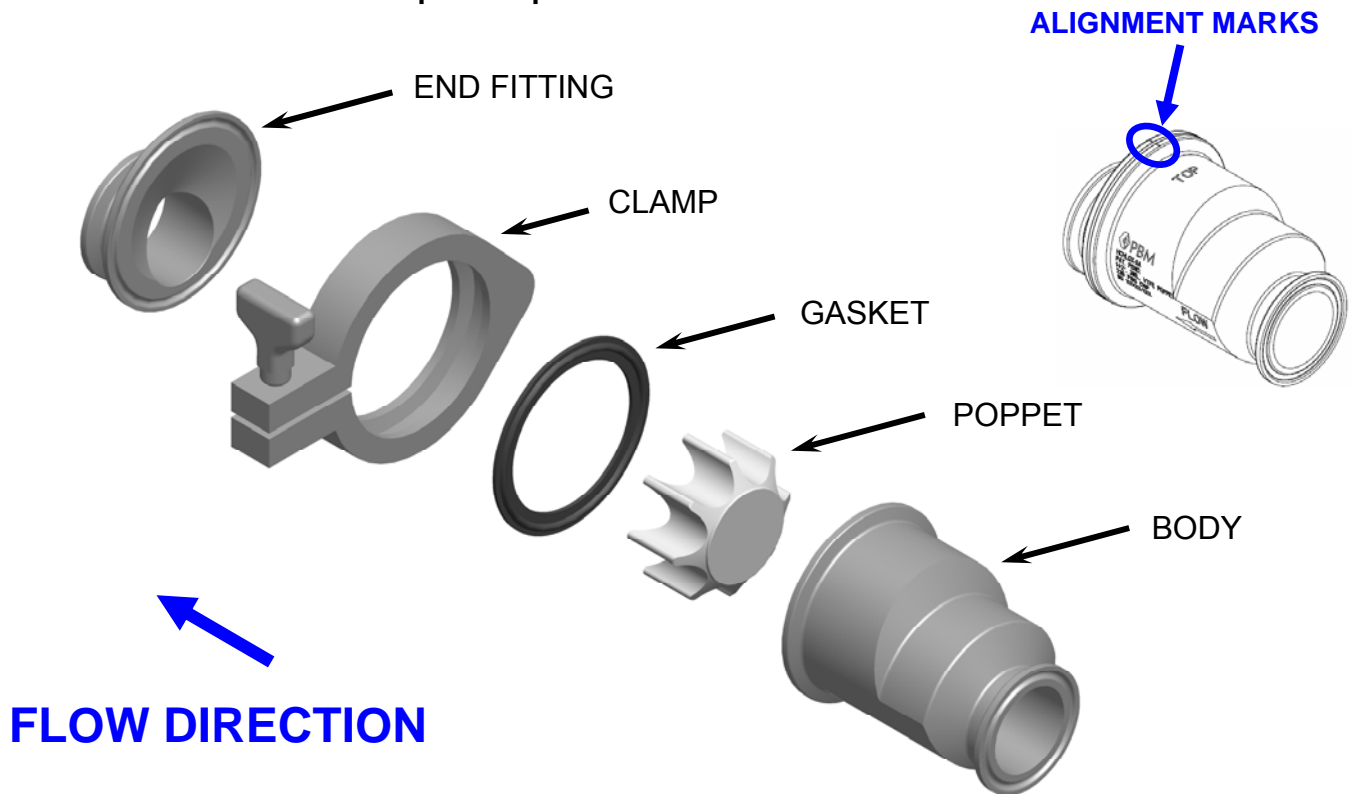

**PBM, Inc.**

1070 Sandy Hill Road, Irwin, PA 15642

Phone: (724) 863-0550 or (800) 967-4PBM

Fax: (724) 864-9255

Web: [www.pbmvalve.com](http://www.pbmvalve.com)

E-mail: [info@pbmvalve.com](mailto:info@pbmvalve.com)



LT-154 7/09