



APPLICATION BRIEF - 08/0805

INDUSTRY: CHEMICAL

PRODUCT: ANGLE STEM FLUSH TANK BALL VALVE WITH PURGE PORT AND RISING STEM SAMPLING VALVE

MEDIA: VARIOUS CHEMICALS USED IN PETROLEUM RESEARCH

IMI PBM Solution:

A Canadian chemical and petroleum research firm acquired an old tank that had an existing PBM flush tank weld pad installed. The customer needed to refurbish the tank and install a new flush bottom valve that would adapt to the existing weld pad, as well as provide a means of sampling the various products that would drain through the valve. PBM's angle stem flush tank ball valve adapted easily to the existing PBM weld pad. PBM added a purge port that accepted a PBM sanitary rising stem sample valve to provide means of sampling product.

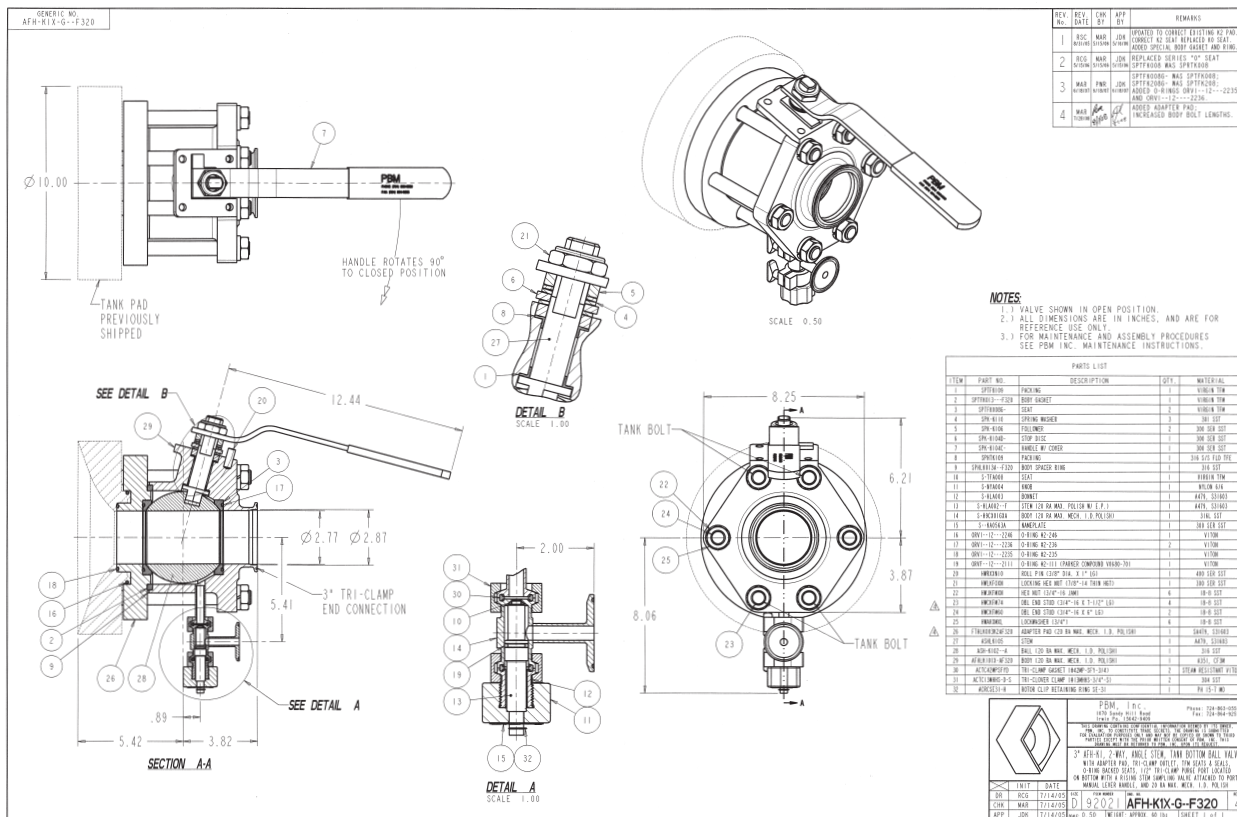

1070 SANDY HILL ROAD, IRWIN, PA 15642 USA
 1-800-967-4PBM
 WWW.PBMVALVE.COM
 INFO.PBMVALVE@IMI-CRITICAL.COM

