



APPLICATION BRIEF - 08/0805

INDUSTRY: CHEMICAL

PRODUCT: ANGLE STEM FLUSH TANK BALL VALVE WITH PURGE PORT AND RISING STEM SAMPLING VALVE

MEDIA: VARIOUS CHEMICALS USED IN PETROLEUM RESEARCH

IMI PBM Solution:

A Canadian chemical and petroleum research firm acquired an old tank that had an existing IMI PBM Flush Tank weld pad installed. The customer needed to refurbish the tank and install a new flush bottom valve that would adapt to the existing weld pad, as well as provide a means of sampling the various products that would drain through the valve. IMI PBM's Angle Stem Flush Tank Ball Valve adapted easily to the existing IMI PBM weld pad. IMI PBM added a purge port that accepted a IMI PBM sanitary Rising Stem Sampling Valve to provide means of sampling product.

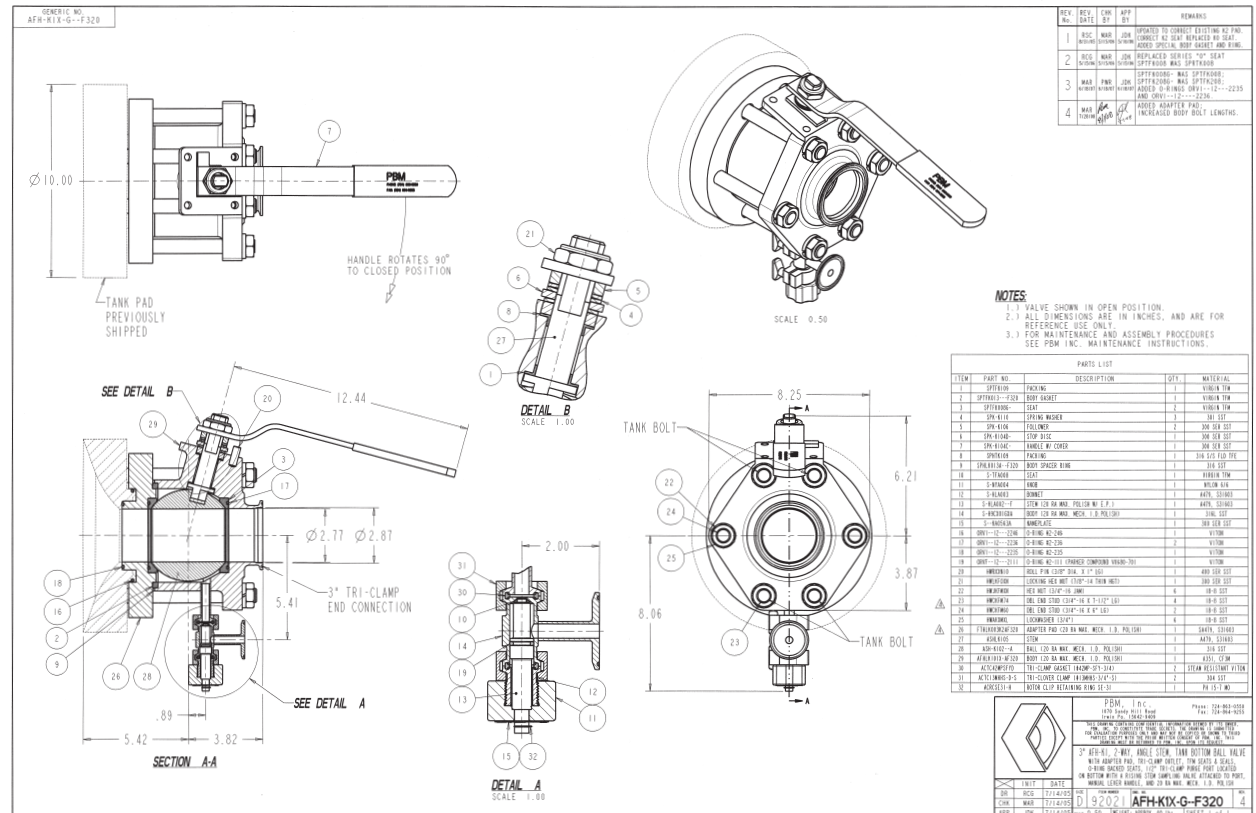

IMI PBM • 1070 SANDY HILL ROAD • IRWIN • PA • 15642 • USA

PBMVALVE.COM • 1.800.967.4PBM • INFO.PBMVALVE@IMI-CRITICAL.COM