



APPLICATION BRIEF - 11/0805

INDUSTRY: CHEMICAL

PRODUCT: ANGLE STEM FLUSH TANK BALL VALVE, AUTOMATED, WITH SPECIAL ADAPTER WELD PAD

MEDIA: CELLULOSE RESINS AND ACETIC ACID

IMI PBM Solution:

An International Chemical company was having problems with originally installed “plunger” style drain valves on their mixing tanks. Product would adhere to the plunger and cut the packing which resulted in leaks and the need for frequent repairs. The customer wanted to replace the plunger valves with a reliable valve that offered better flow rates and minimal “pocket” area that would adapt to the existing connection on the tank. PBM designed an adapter pad that mated to the existing tank flange and replaced the plunger valves with automated angle stem flush tank ball valves. The PBM design offered unrestricted flow which allowed the tanks to drain faster resulting in improved productivity.

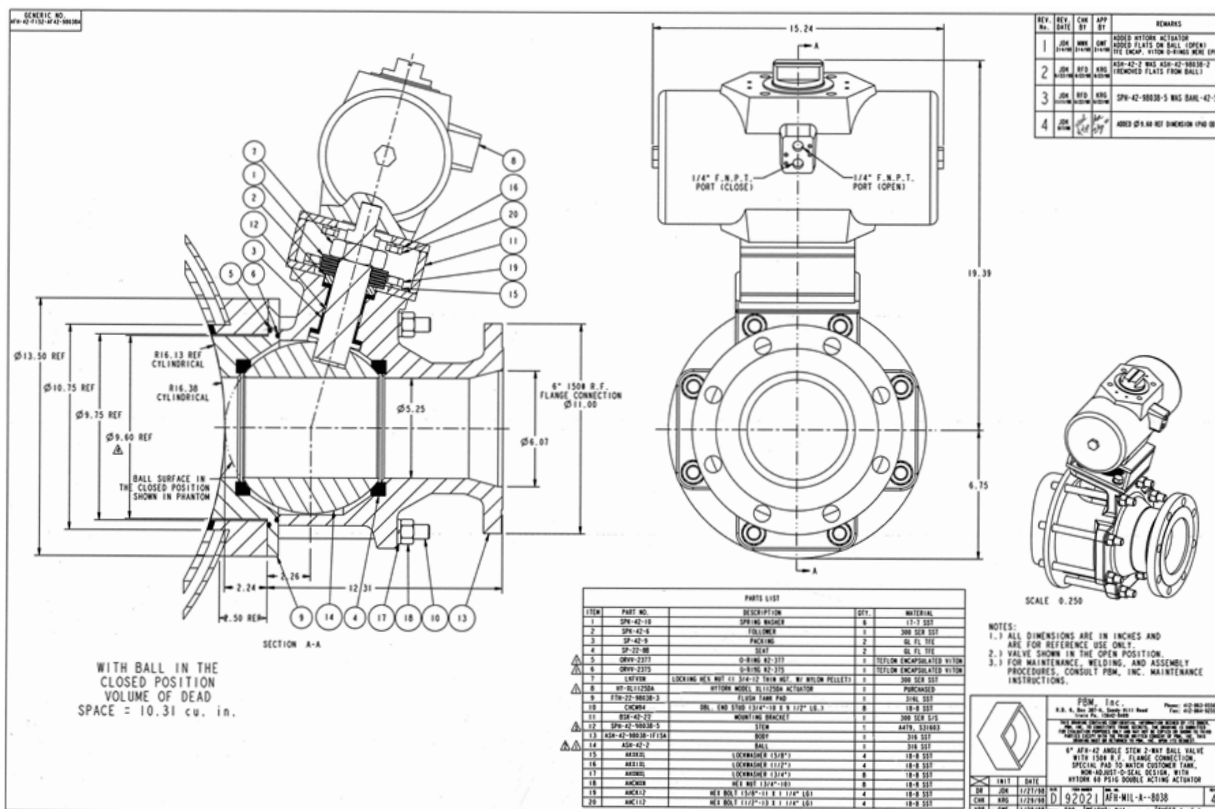

1070 SANDY HILL ROAD, IRWIN, PA 15642 USA
 1-800-967-4PBM
 WWW.PBMVALVE.COM
 INFO.PBMVALVE@IMI-CRITICAL.COM

