



APPLICATION BRIEF - 30/0106

INDUSTRY: CHEMICAL
PRODUCT: PIGGABLE 3-WAY VALVE
MEDIA: AUTOMOTIVE PAINT

IMI PBM Solution:

A major automotive manufacturer required 1/2 inch 3-way piggable valves for use in a robotic paint spraying system. PBM custom designed and fabricated true-bore™ 3-way cavity-free valves with 120 degree turning radius that easily allowed the pig (for cleaning the line) to pass through the valve. These valves, powered by an electric motor operator, increased productivity and reliability by allowing the manufacturer's robotic paint sprayer to clean and switch colors at a faster rate. Innovation – it's what PBM is all about!

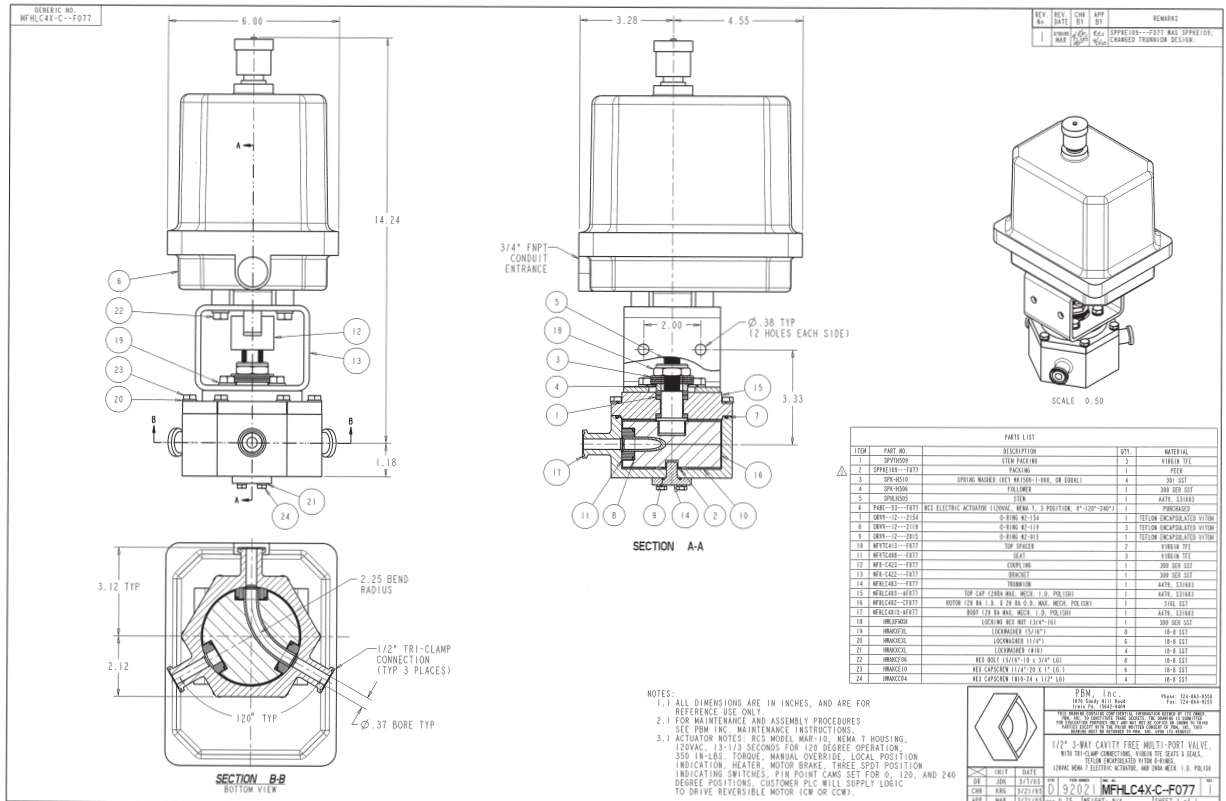

1070 SANDY HILL ROAD, IRWIN, PA 15642 USA
1-800-967-4PBM
WWW.PBMVALVE.COM
INFO.PBMVALVE@IMI-CRITICAL.COM

