



APPLICATION BRIEF - 32/0506

INDUSTRY: CHEMICAL

PRODUCT: 4" ANGLE STEM FLUSH TANK BALL VALVE WITH DECLUTCHABLE MANUAL OVERRIDE

MEDIA: COMMERCIAL ROOF COATING

IMI PBM Solution:

A major southern US manufacturer of roof coatings was looking for a valve to drain a temperature controlled process vessel. PBM supplied a 4 inch angle stem flush tank ball valve that allowed the automation package to clear the process vessel's heating and cooling jackets. Special seating material was used to accommodate the process media. A manual declutchable override was installed in the unlikely event the valve had to be operated by hand.

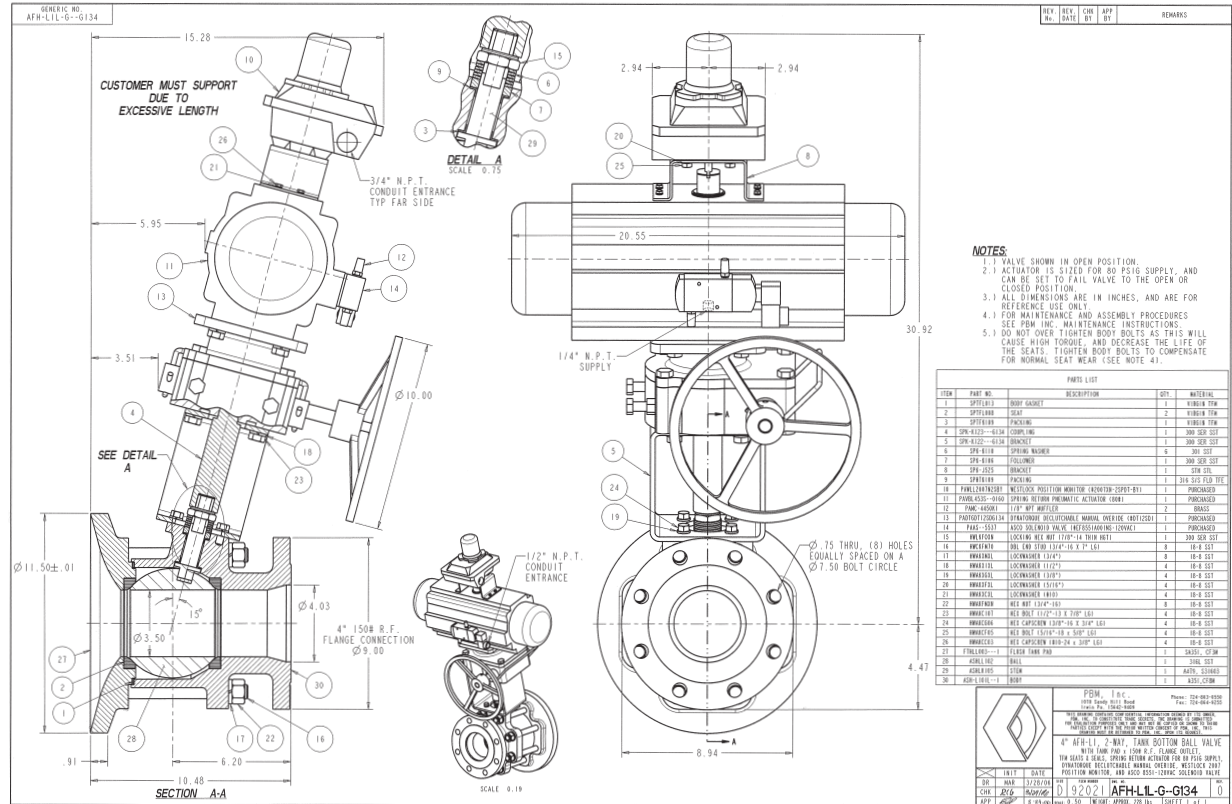

1070 SANDY HILL ROAD, IRWIN, PA 15642 USA
 1-800-967-4PBM
 WWW.PBMVALVE.COM
 INFO.PBMVALVE@IMI-CRITICAL.COM

