



APPLICATION BRIEF - 52/0610

INDUSTRY: AGRICULTURAL CHEMICAL PROCESS

PRODUCT: PBM TANK BOTTOM VALVE

MEDIA: CHEMICALS

IMI PBM Solution:

The customer needed a valve using zirconium as the valve's material of construction for a specific chemistry in a customer's agricultural chemical process. This vessel will have the general condition of high pH and high temperature. The nature of the process had been developed by the customer over time at another location, and we were told that zirconium was the definitive choice of valve material

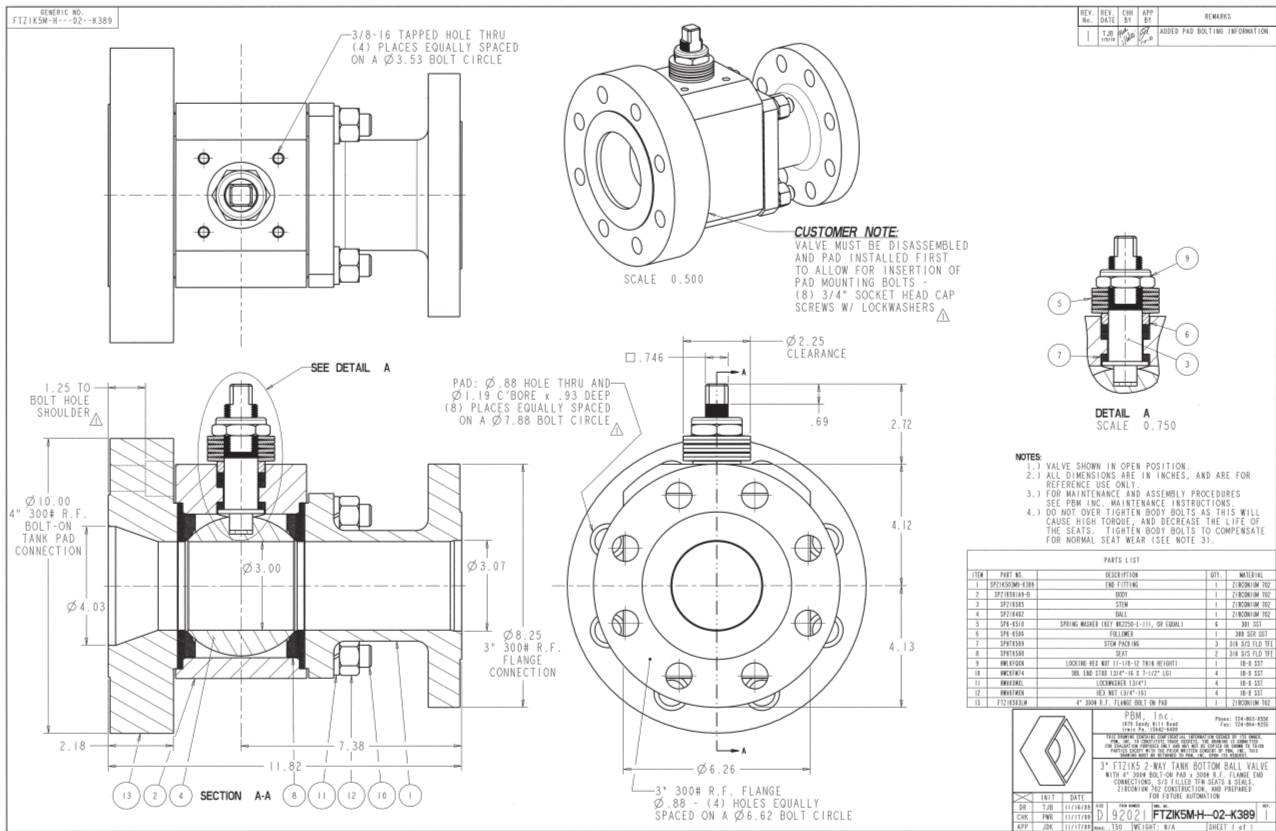

1070 SANDY HILL ROAD, IRWIN, PA 15642 USA
 1-800-967-4PBM
 WWW.PBMVALVE.COM
 INFO.PBMVALVE@IMI-CRITICAL.COM

