



APPLICATION BRIEF - 57/1010

INDUSTRY: CHEMICAL

PRODUCT: 3" MULTI-PORT BALL VALVE IN TANDEM ASSEMBLY FULLY ACTUATED

MEDIA: THERMAL AND COLD TRANSFER FLUID

IMI PBM Solution:

A chemical manufacturer was looking for a multi-port valve which would divert their thermal heat-transfer fluid used in their process. The customer went with PBM because of PBM's proven track record with this particular chemical manufacturer for using innovative designs and for the production of high quality valves. PBM designed two multi-port valves with carbon/graphite seats and seals that work in tandem and that are driven by a single actuator. The hot transfer fluid diverts into a loop while the cold fluid is introduced into the main line.

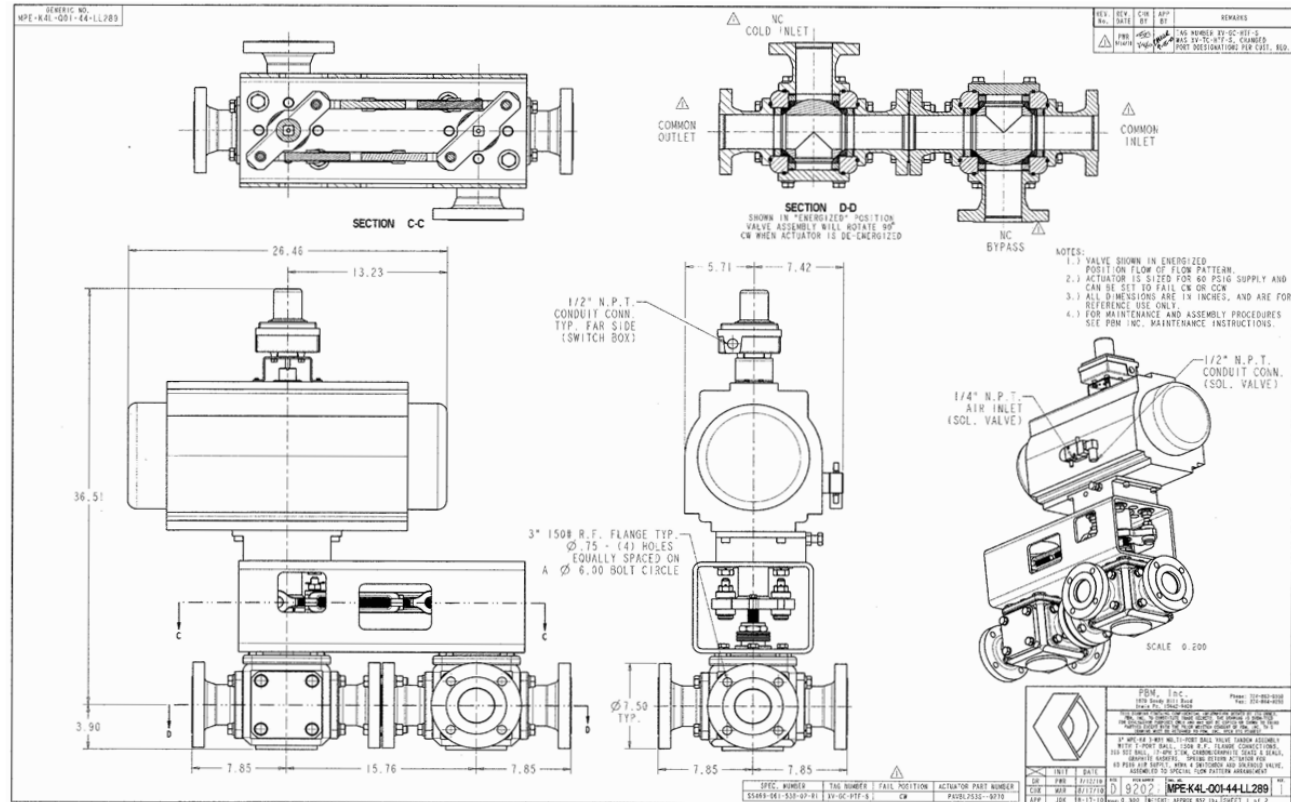

1070 SANDY HILL ROAD, IRWIN, PA 15642 USA
 1-800-967-4PBM
 WWW.PBMVALVE.COM
 INFO.PBMVALVE@IMI-CRITICAL.COM

