



# APPLICATION BRIEF - 74/1211

**INDUSTRY:** CHEMICAL

**PRODUCT:** ANGLE STEM FLUSH TANK

**MEDIA:** HIGH QUALITY FILM FOR THE MOTION PICTURE INDUSTRY

## IMI PBM Solution:

A mid-Atlantic firm was dissolving “paper” chips in acetic acid to make a cellulose “batter”. When chips got stuck in the dead space, they contaminated the product. The solution was to use a modified version of PBM’s angle stem valve modified to adapt to the customer’s existing tank outlet connection. The PBM valve fit into the tight space envelope, had an increased port diameter that increased drain and increased productivity, and most importantly decreased dead space thus eliminating potential contamination issues.

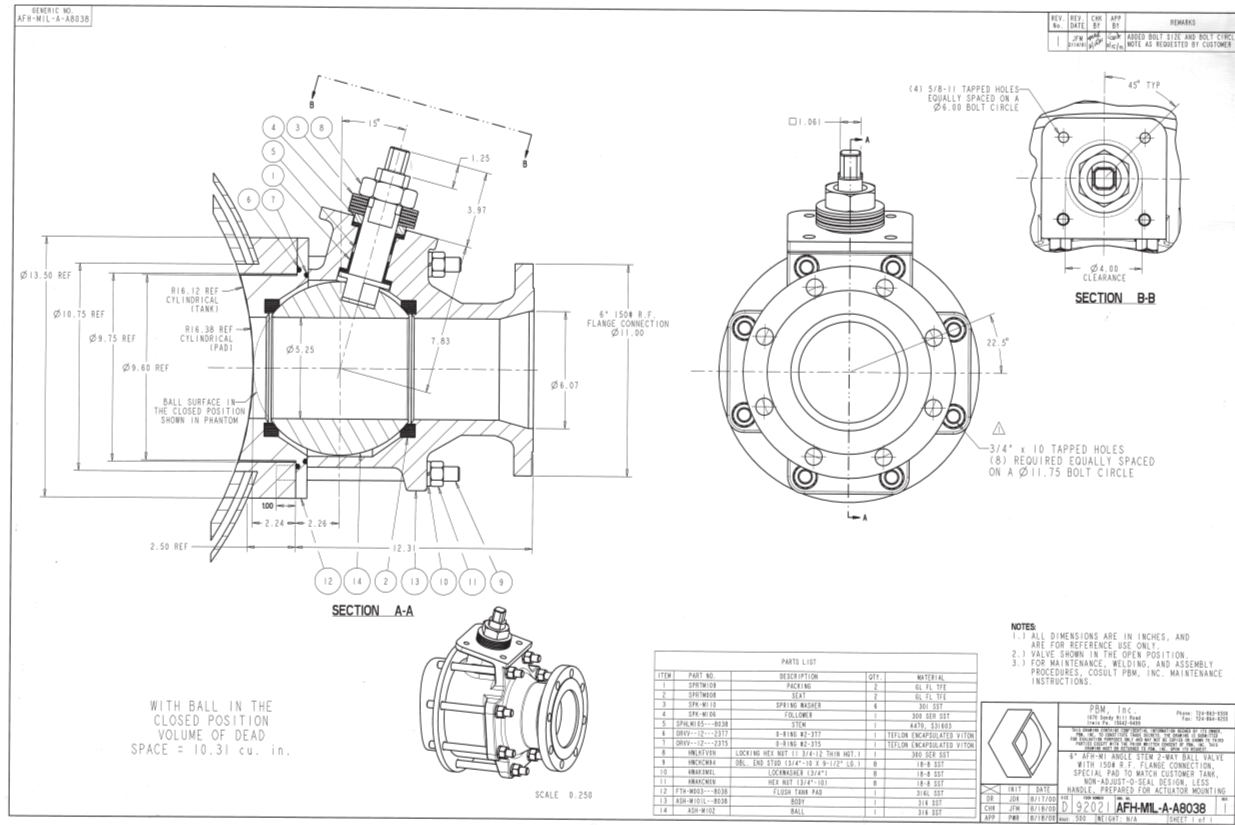

1070 SANDY HILL ROAD, IRWIN, PA 15642 USA  
1-800-967-4PBM  
WWW.PBMVALVE.COM  
INFO.PBMVALVE@IMI-CRITICAL.COM

