



# APPLICATION BRIEF - 06/0805

**INDUSTRY:** CONSUMER PRODUCTS

**PRODUCT:** ANGLE STEM FLUSH TANK WITH SPRAY NOZZLE BALL, ACTUATOR, LIMIT SWITCH

**MEDIA:** CIP SOLUTION

## IMI PBM Solution:

An International manufacturer of consumer products required a means of cleaning the underside of agitators in a tank that mixed toothpaste and dental products. PBM provided a solution by machining an integral 90 degree spray nozzle into the ball of an Angle stem flush tank ball valve. The valve remains closed during the mixing process, and is used between batches to introduce CIP and rinse solutions through the spray nozzle ball into the tank bottom to completely clean the hard-to-reach undersides of the agitator blades.

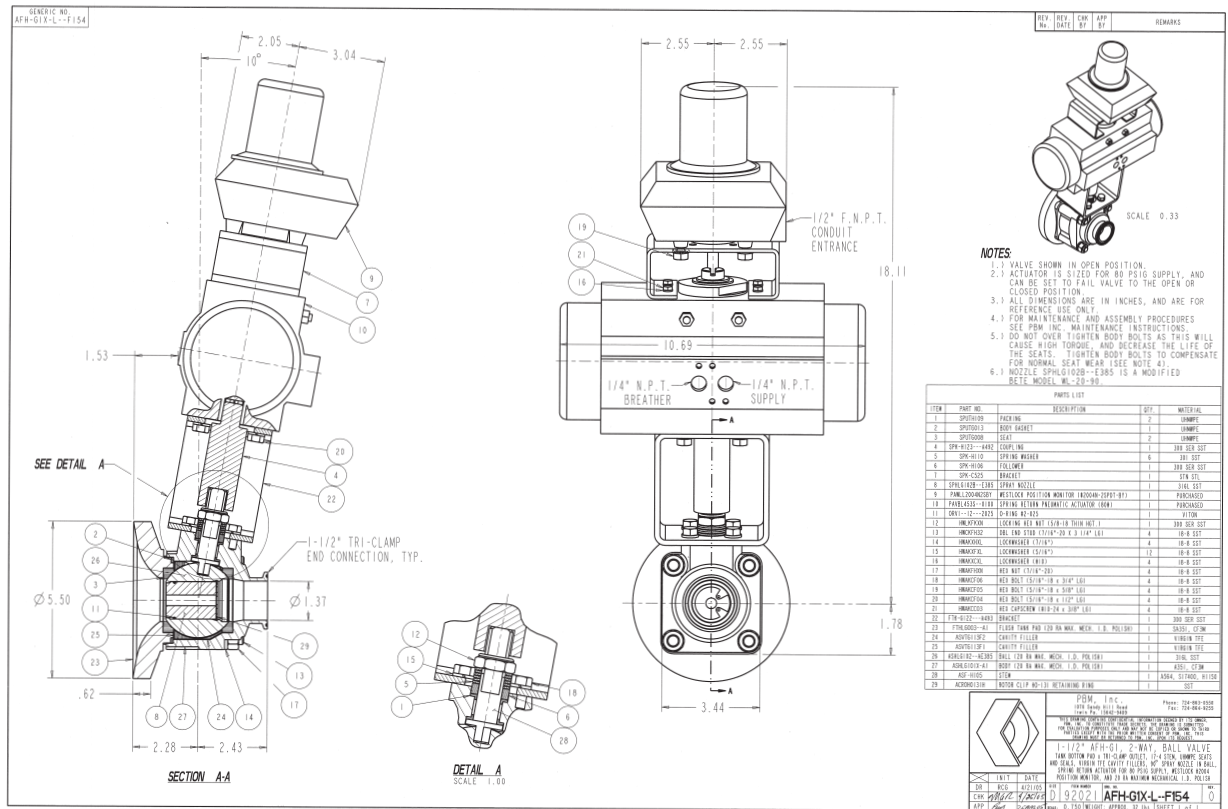

1070 SANDY HILL ROAD, IRWIN, PA 15642 USA  
 1-800-967-4PBM  
 WWW.PBMVALVE.COM  
 INFO.PBMVALVE@IMI-CRITICAL.COM

