



APPLICATION BRIEF - 22/0805

INDUSTRY: CONSUMER PRODUCTS
PRODUCT: RISING STEM SAMPLING VALVE
MEDIA: WATER

IMI PBM Solution:

A major consumer products manufacturer was looking to sample water from a filter housing. PBM integrated its Rising stem sampling valve design into a 1 inch flange fitting that attached to an existing flange connection on the filter housing. This design allowed the seal of the sampling valve to be flush with the inside-facing flange face.

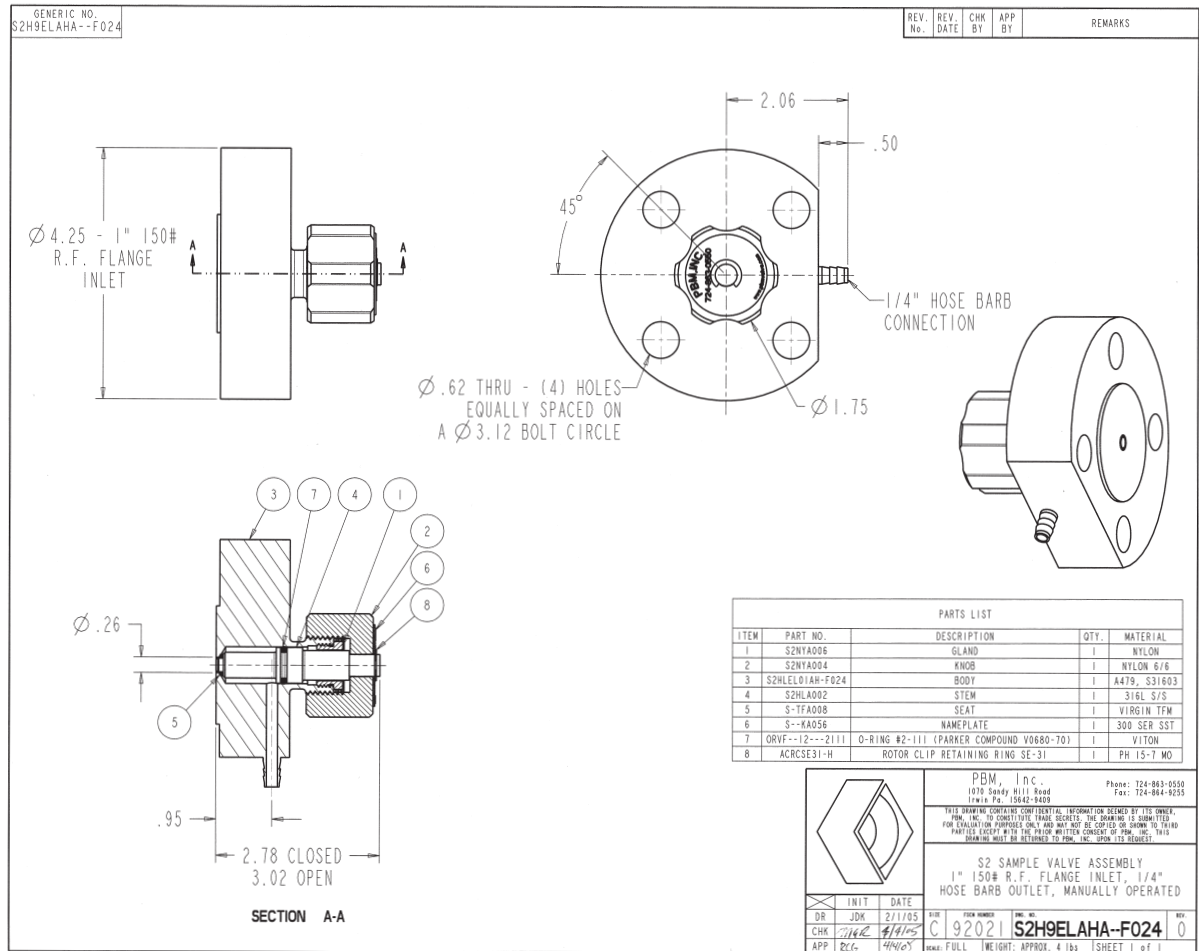

1070 SANDY HILL ROAD, IRWIN, PA 15642 USA
 1-800-967-4PBM
 WWW.PBMVALVE.COM
 INFO.PBMVALVE@IMI-CRITICAL.COM

