



APPLICATION BRIEF - 71/1211

INDUSTRY: CONSUMER PRODUCTS

PRODUCT: DIVERTER PORT SANITARY BALL VALVES

MEDIA: LIQUID SOAP LINE

IMI PBM Solution:

A Cosmetic company often relied on diaphragm valves to handle their sanitary applications. PBM's adjustable sealing not only allowed in-line adjustment for normal valve wear, but also allowed for Clean-in-Place without process interruption. They preferred not to use purge ports to assist in valve cleaning, and discovered how milled ball flats on both the upstream and downstream side could accommodate this instead. They also like the benefits of the lift out/swing out feature and reviewed the various seat and seal material options for steam applications. The valve had to handle the 176°F temperatures of CIP service.

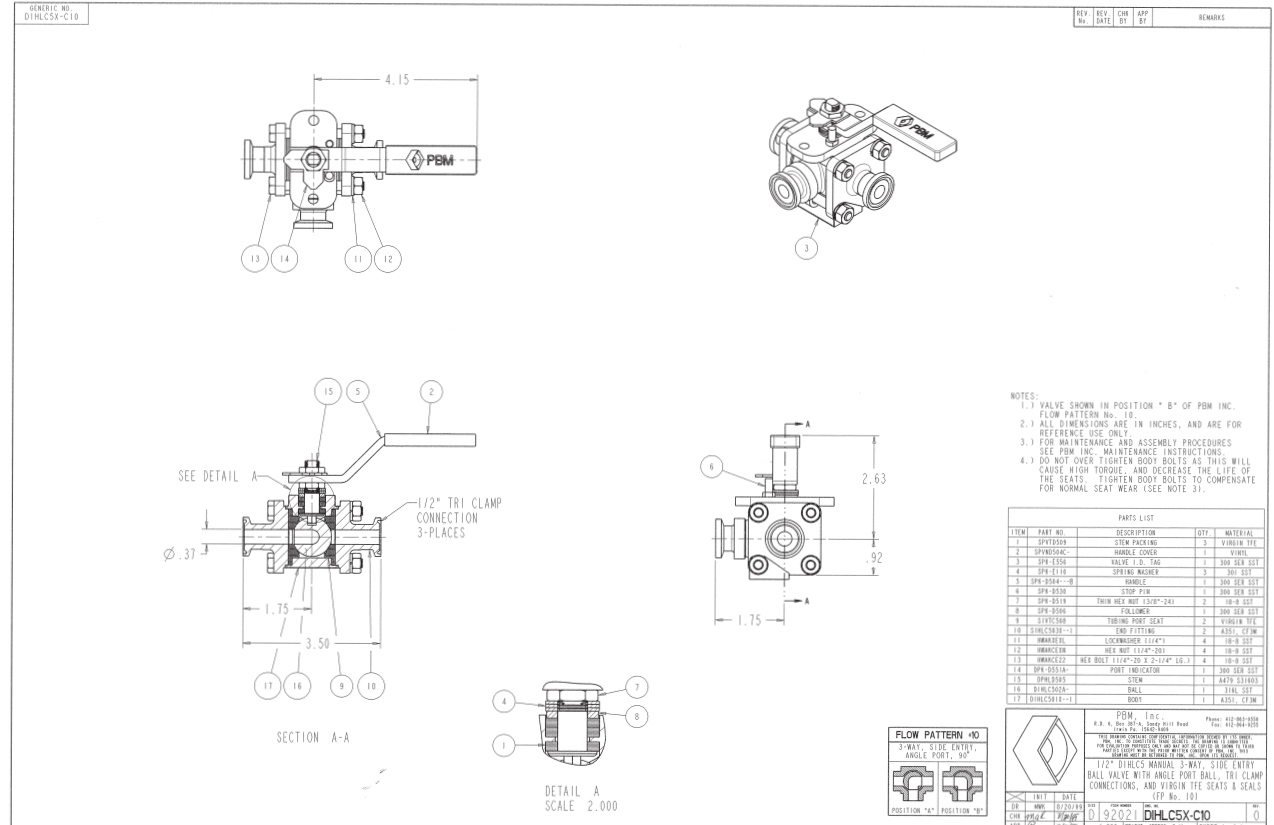

1070 SANDY HILL ROAD, IRWIN, PA 15642 USA
1-800-967-4PBM
WWW.PBMVALVE.COM
INFO.PBMVALVE@IMI-CRITICAL.COM

