



APPLICATION BRIEF - 78/1211

INDUSTRY: CONSUMER PRODUCTS
PRODUCT: 2-WAY SELF FLUSHING VALVES
MEDIA: SHAMPOO

IMI PBM Solution:

A major producer of home and personal care products was having a problem getting enough flow through a diaphragm and pinch valves. PBM's Self Cleaning valves provided full unobstructed flow resulting in no shampoo being trapped in the valve cavity. PBM self-cleaning balls join the cavity of the valve with the piping when the valve is open. The holes allow product to fill the cavity just as it fills the piping. When flushing the lines, the cleaning fluid fills the cavity and displaces the product. The valves remain double seated and seal in either direction when closed.

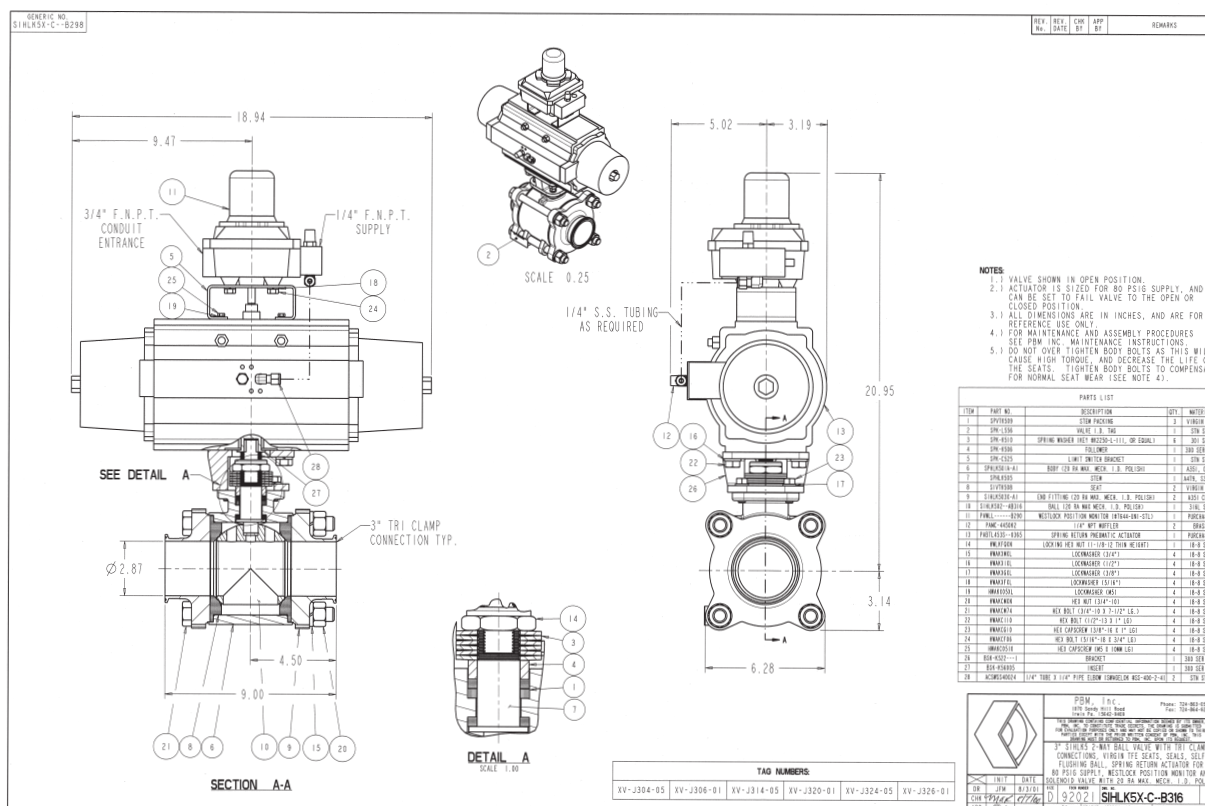

1070 SANDY HILL ROAD, IRWIN, PA 15642 USA
 1-800-967-4PBM
 WWW.PBMVALVE.COM
 INFO.PBMVALVE@IMI-CRITICAL.COM

