



APPLICATION BRIEF - 51/0610

INDUSTRY: ENERGY
PRODUCT: PBM CENTER SECTIONS
MEDIA: ROCKET FUEL

IMI PBM Solution:

Baker Perkins center sections to replace obsolete Contramatic valves by using PBM product placed between Contramatic ends.

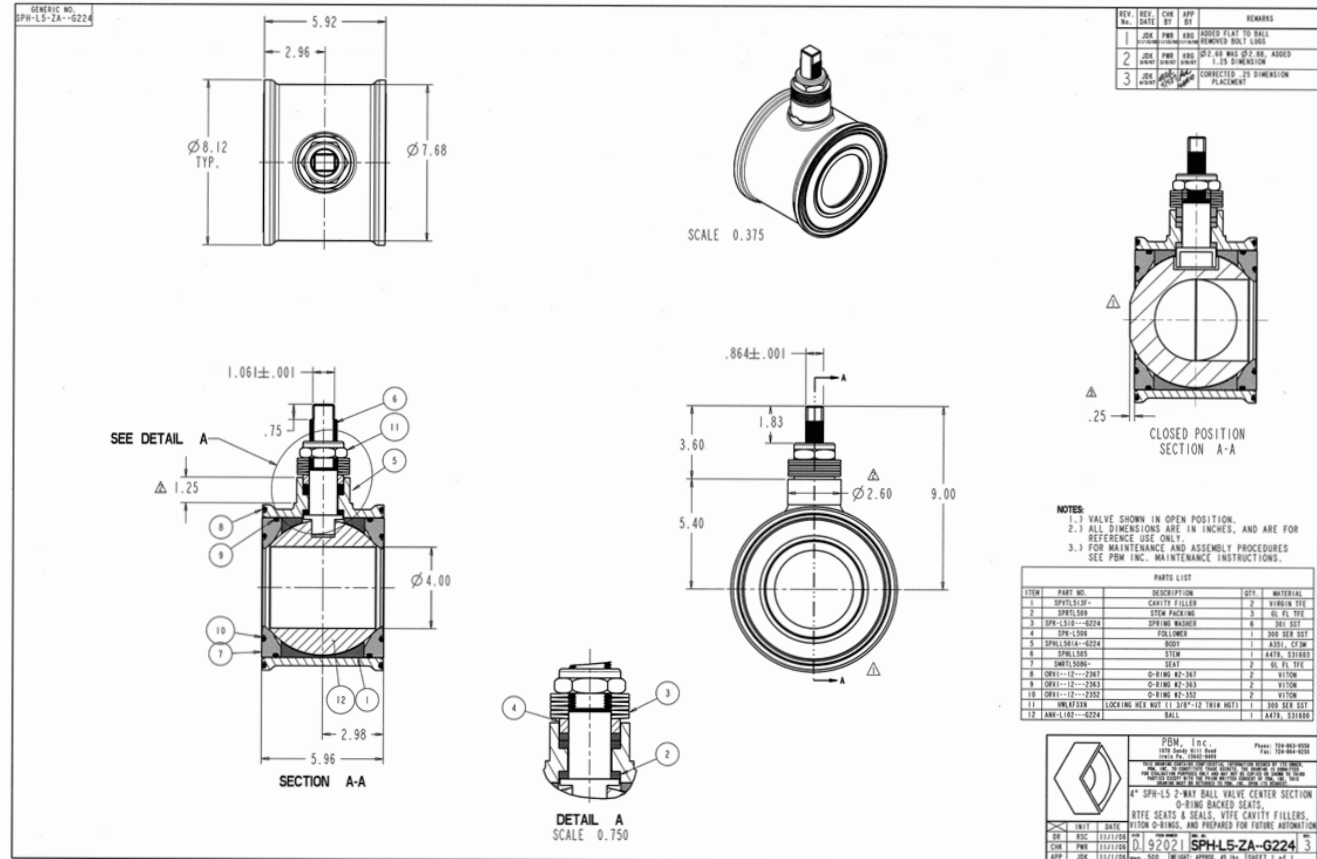

1070 SANDY HILL ROAD, IRWIN, PA 15642 USA
 1-800-967-4PBM
 WWW.PBMVALVE.COM
 INFO.PBMVALVE@IMI-CRITICAL.COM

