



# APPLICATION BRIEF - 13/0805

**INDUSTRY:** FOOD & BEVERAGE

**PRODUCT:** MULTI-PORT BALL VALVE

**MEDIA:** MUST (GRAPES, SKINS, SEED, STEMS)

## IMI PBM Solution:

A major California winery was looking for a valve to handle the flow of must, which would flow through a main header and into one of 24 fermenters in a tank farm. The primary concern was to maintain the integrity of the grape by having a valve that allowed full unobstructed flow, no sharp edges, and limited voids. PBM provided 24 automated true-bore™ 3-way multi-port ball valves with smooth ball edges to minimize damage to the grapes, body cavity fillers to eliminate void areas in the body where product might collect, and metal encapsulated ultra-high molecular weight polyethylene seats to handle the abrasive grape stems and seeds. PBM's ability to design a valve to meet the application along with on-time delivery resulted in a satisfied customer who was able to have the process up and running prior to the next grape harvest.

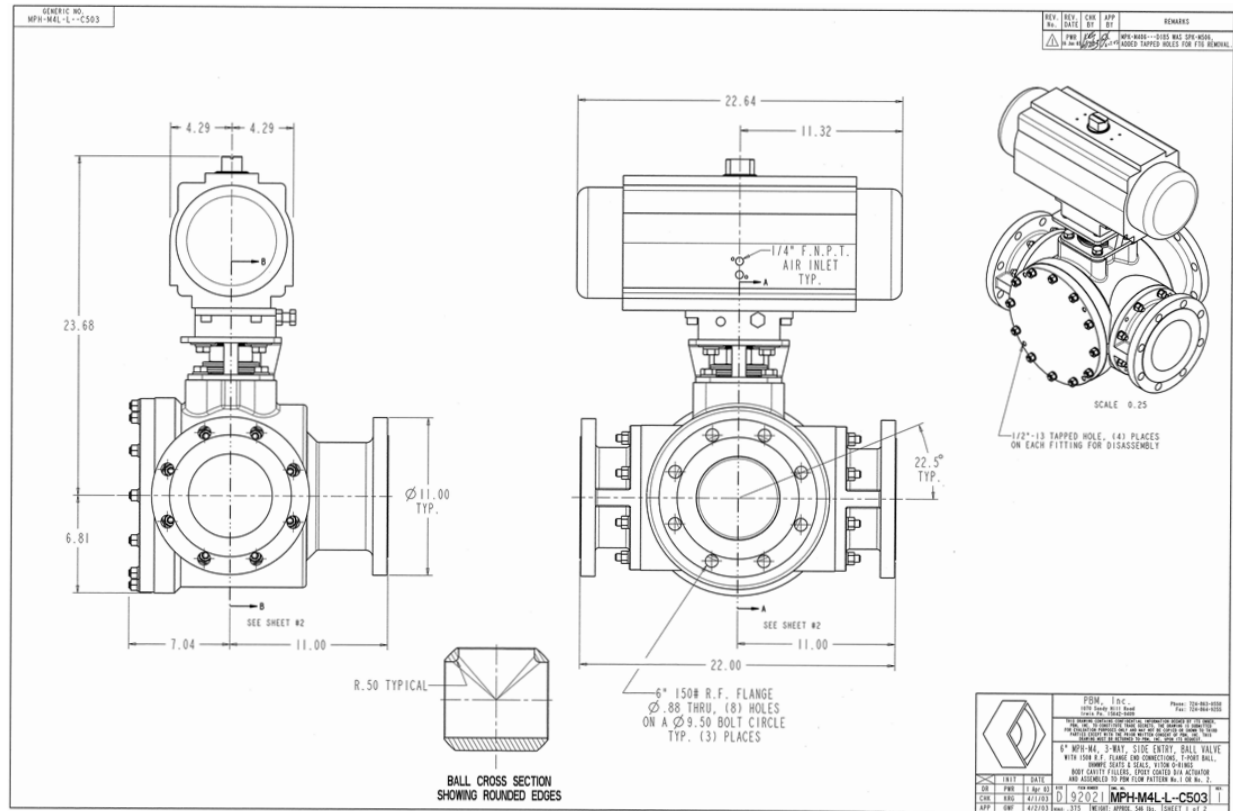

1070 SANDY HILL ROAD, IRWIN, PA 15642 USA  
 1-800-967-4PBM  
 WWW.PBMVALVE.COM  
 INFO.PBMVALVE@IMI-CRITICAL.COM

