



APPLICATION BRIEF - 42/1008

INDUSTRY: FOOD & BEVERAGE
PRODUCT: DOUBLE BLOCK AND BLEED VALVE
MEDIA: ALCOHOL

IMI PBM Solution:

A large distiller of alcoholic beverages needed Double Block and Bleed valves with roddable hot tap to address plugged pressure taps on the 250 steam line.

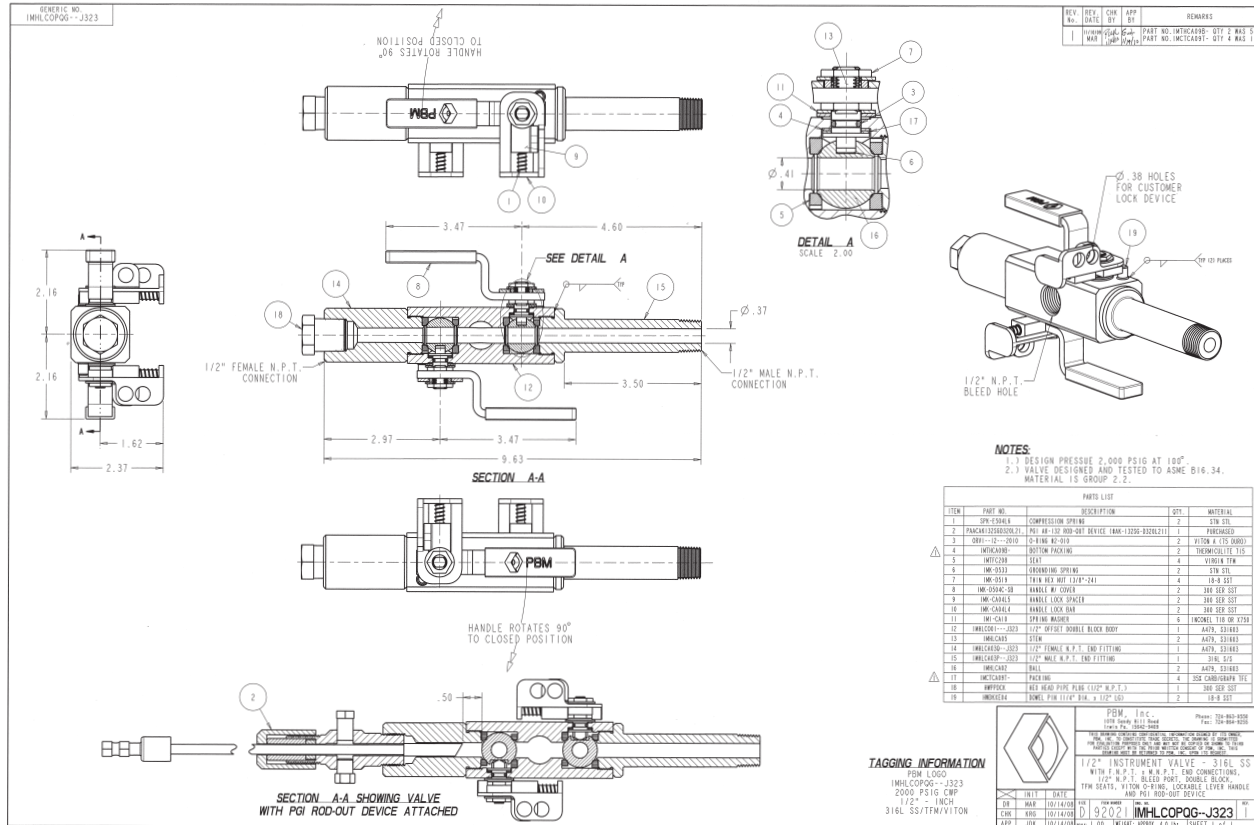

1070 SANDY HILL ROAD, IRWIN, PA 15642 USA
 1-800-967-4PBM
 WWW.PBMVALVE.COM
 INFO.PBMVALVE@IMI-CRITICAL.COM

