



APPLICATION BRIEF - 114/1016

INDUSTRY: PHARMACEUTICAL

PRODUCT: CLEAN STEAM DOUBLE BLOCK AND BLEED VALVES

MEDIA: PURE STEAM FEED

IMI PBM Solution:

A major pharmaceutical company needed forged 3 and 4-inch double block and bleed clean steam valves.

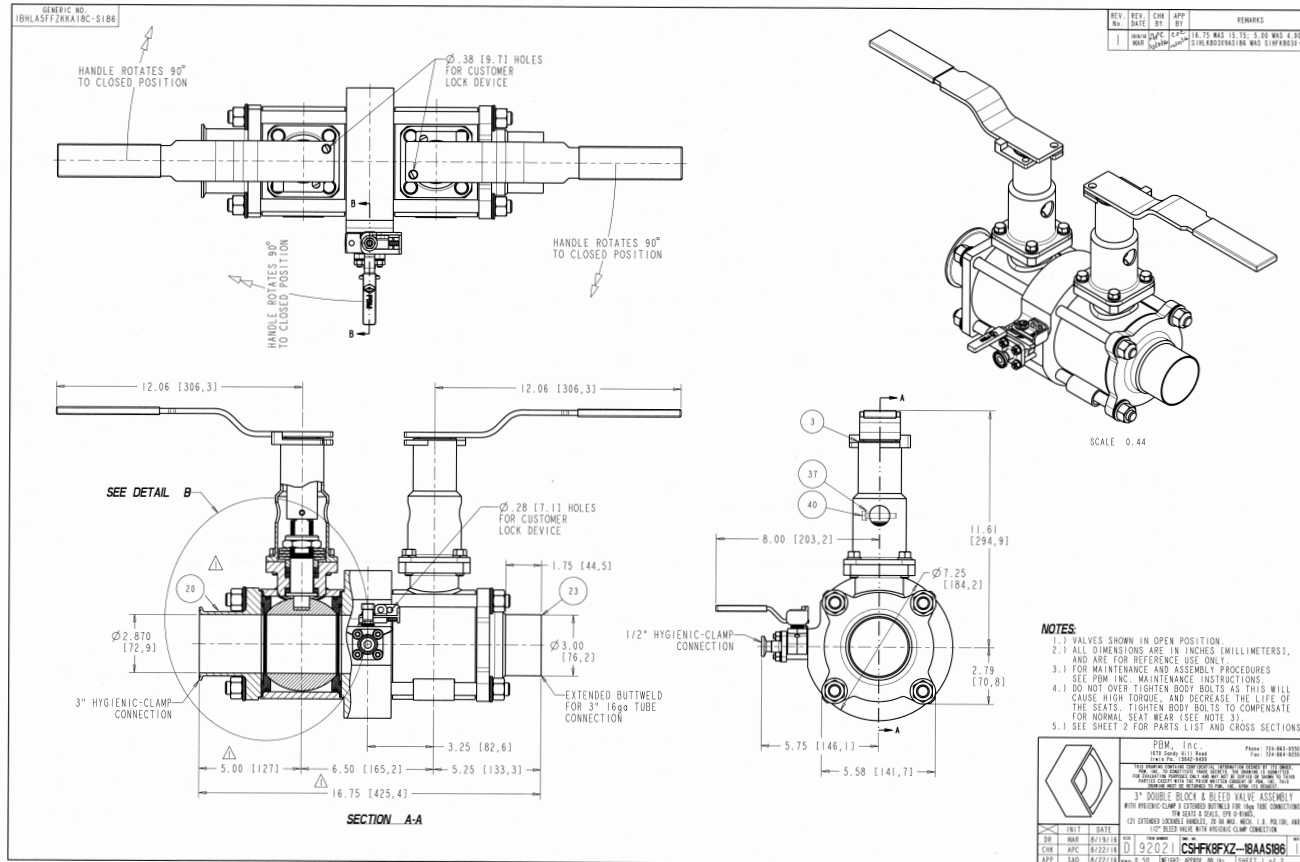

1070 SANDY HILL ROAD, IRWIN, PA 15642 USA
 1-800-967-4PBM
 WWW.PBMVALVE.COM
 INFO.PBMVALVE@IMI-CRITICAL.COM

