



APPLICATION BRIEF - 15/0805

INDUSTRY: PHARMACEUTICAL

PRODUCT: FLUSH TANK BALL VALVE, REDUCED POCKET

MEDIA: DEIONIZED (DI) WATER

IMI PBM Solution:

A west coast US Pharmaceutical company added an additional DI water loop to their facility. They were looking for clean and reliable automated valves that would deliver consistent DI water to each point of use in the loop. PBM designed a fabflex® assembly consisting of a sanitary Igenix™ flush tank ball valve with a reduced pocket weld pad and unique ball configuration. To ease installation, PBM welded the flush tank pad to a piece of sanitary tubing, which could be orbitally weld in-place at the installation site. After installation and operation, tests were performed to measure and monitor the quality of the DI water. The water quality in the loop containing PBM valves was equal to or better than the quality of water in loops using diaphragm and butterfly valves. Go PBM!

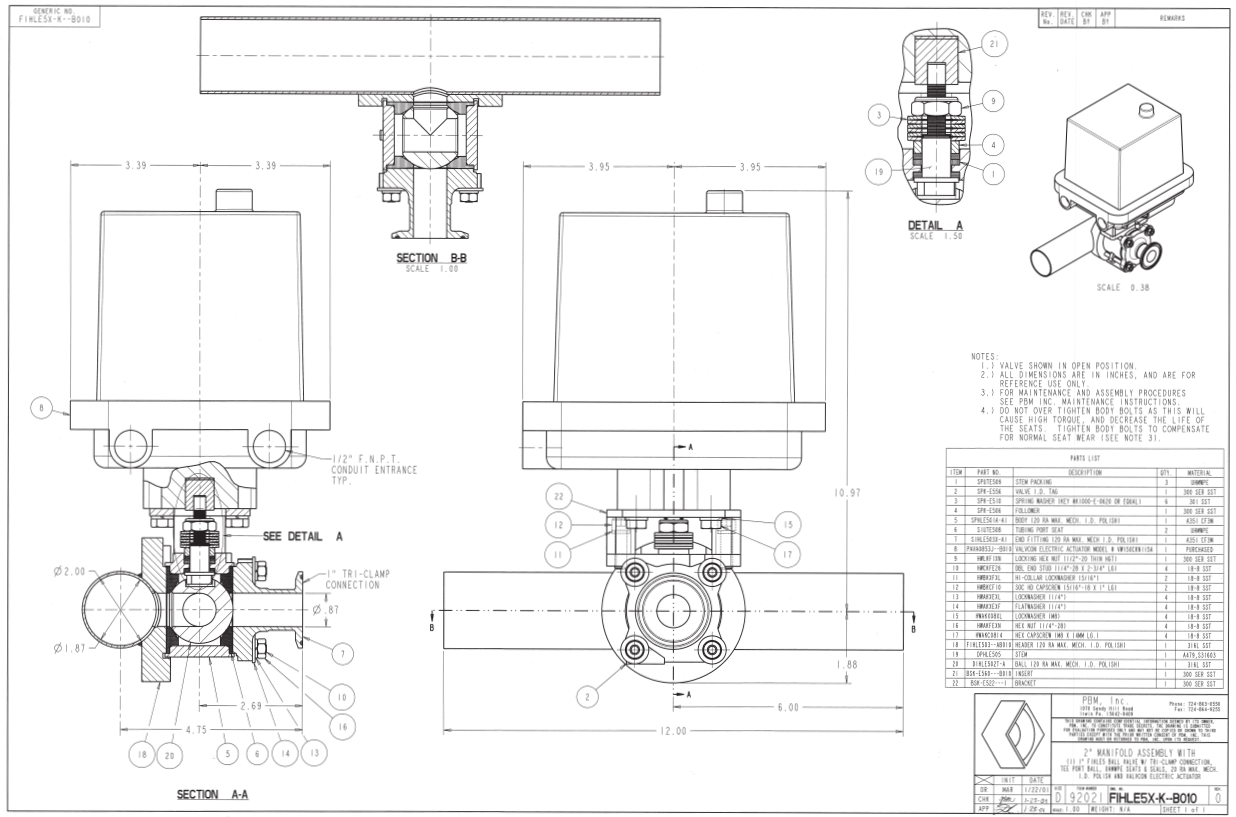

1070 SANDY HILL ROAD, IRWIN, PA 15642 USA
 1-800-967-4PBM
 WWW.PBMVALVE.COM
 INFO.PBMVALVE@IMI-CRITICAL.COM

