



APPLICATION BRIEF - 24/0805

INDUSTRY: PHARMACEUTICAL

PRODUCT: FT FLUSH TANK BALL VALVE, HASTELLOY C-22 MATERIAL, WITH SAMPLE CUP BALL AND PURGE PORTS

MEDIA: PHARMACEUTICAL PREPARATIONS

IMI PBM Solution:

A major pharmaceutical company required a sampling valve to mount on the side of a process mixing tank. The valve was made from Hastelloy C-22 material to handle a vast array of pharmaceutical preparations. The weld pad was machined to a cylindrical radius to match the inside radius of the mixing tank. The “cup” was machined in the ball so when facing the inside of the vessel would fill with a specific volume of the process media that could be extracted for testing without breaking the sterile barrier. The handle rotates 180 degrees to expose the ball to the downstream fitting and allow a sample to be “scooped” out of the ball. Purge ports allow the valve internals to be cleaned and sterilized between sampling.

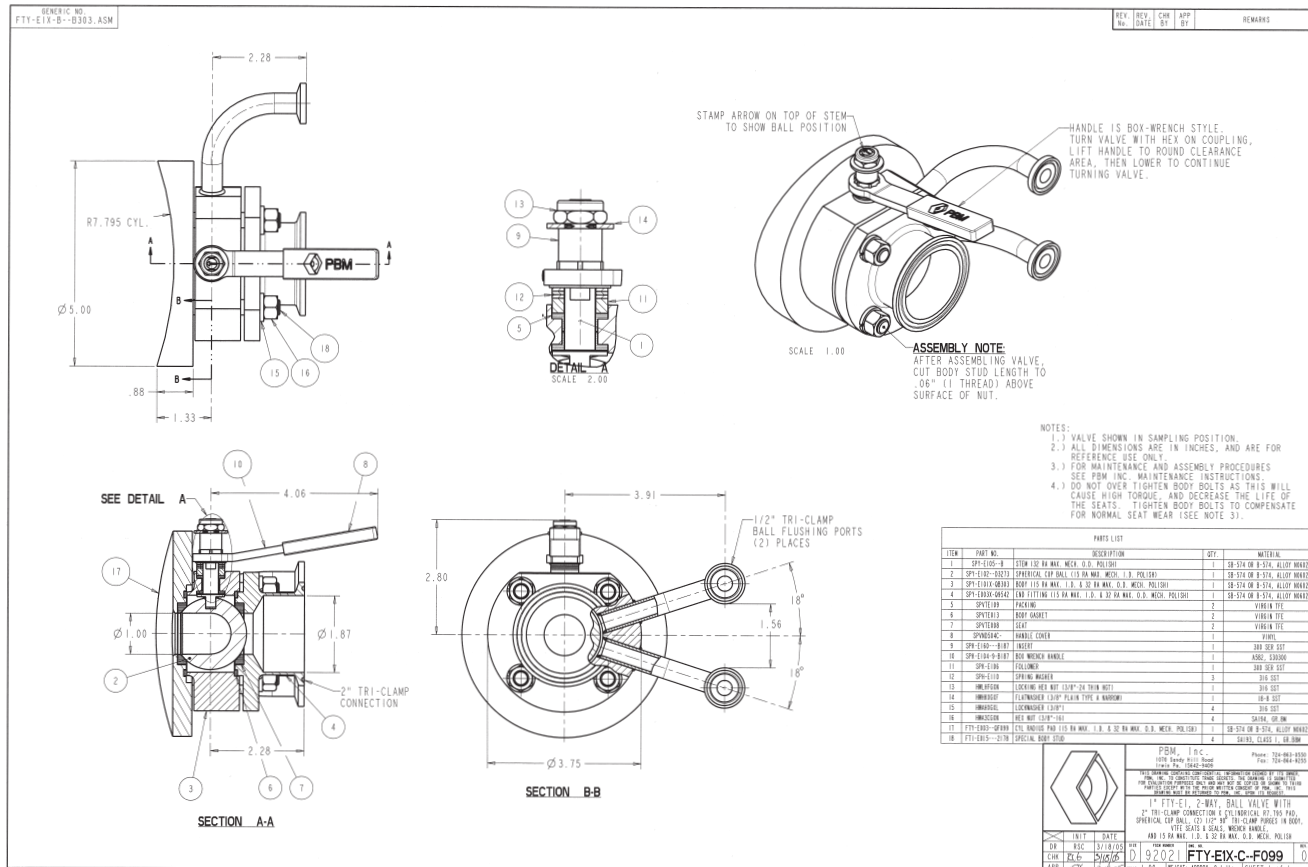

1070 SANDY HILL ROAD, IRWIN, PA 15642 USA
1-800-967-4PBM
WWW.PBMVALVE.COM
INFO.PBMVALVE@IMI-CRITICAL.COM

