



APPLICATION BRIEF - 102/0613

INDUSTRY: REFINERY

PRODUCT: 1 1/2-INCH 1500# CLASS DOUBLE BLOCK & BLEED INSTRUMENT VALVE

MEDIA: GASES AND HYDROCARBONS

IMI PBM Solution:

A major petroleum company selected PBM double block and bleed valves for their safety and reliability, tight shut-off for isolating instrumentation on their Gas Oil Hydrotreater Units.

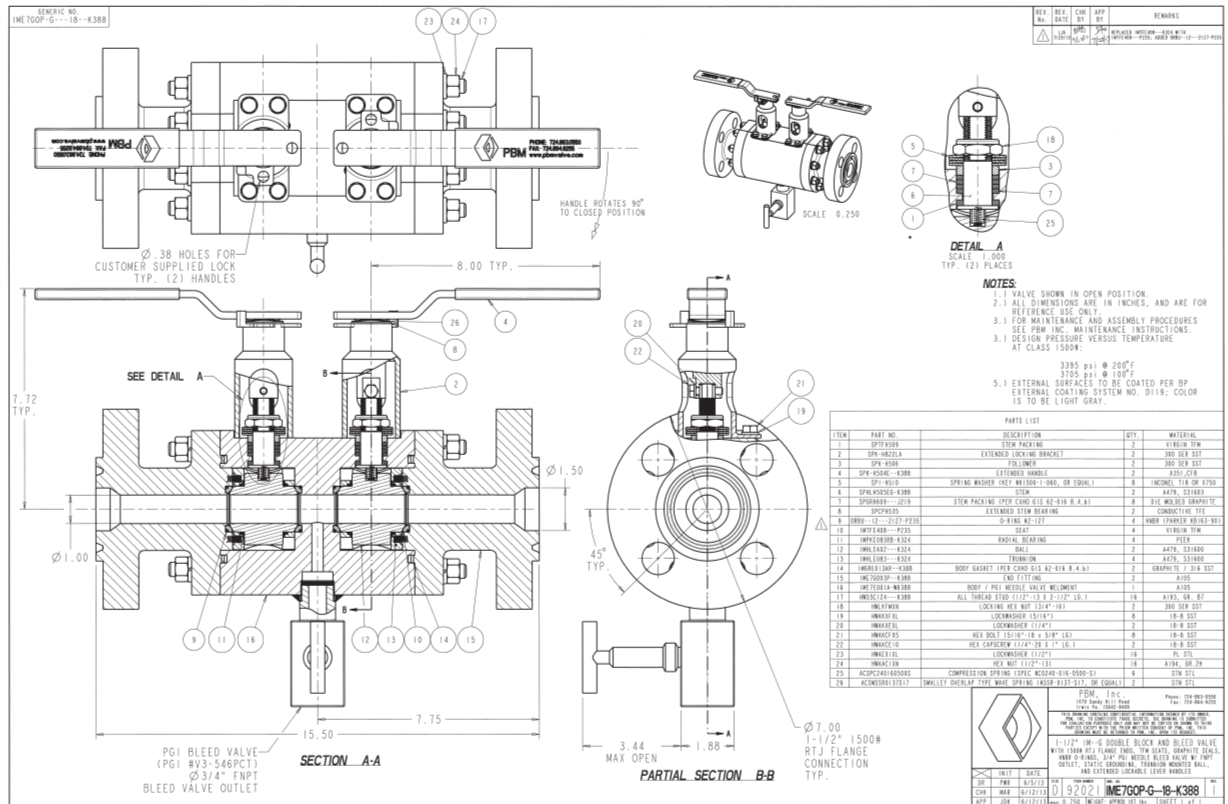

1070 SANDY HILL ROAD, IRWIN, PA 15642 USA
 1-800-967-4PBM
 WWW.PBMVALVE.COM
 INFO.PBMVALVE@IMI-CRITICAL.COM

