



APPLICATION BRIEF - 107/1214

INDUSTRY: REFINING

PRODUCT: DBB-IB, CARBON STEEL/NACE TRIM 2", CLISO

MEDIA: SOUR WATER

IMI PBM Solution:

A major oil refinery needed to convert a site level gauge on a vessel to a magnetic level gauge and two remote transmitters. The isolation requirement was for a double positive isolation arrangement. The PBM solution provided a fire tested, double positive isolation valve that fit their space requirements and met all their safety, reliability, emissions and operating requirements.

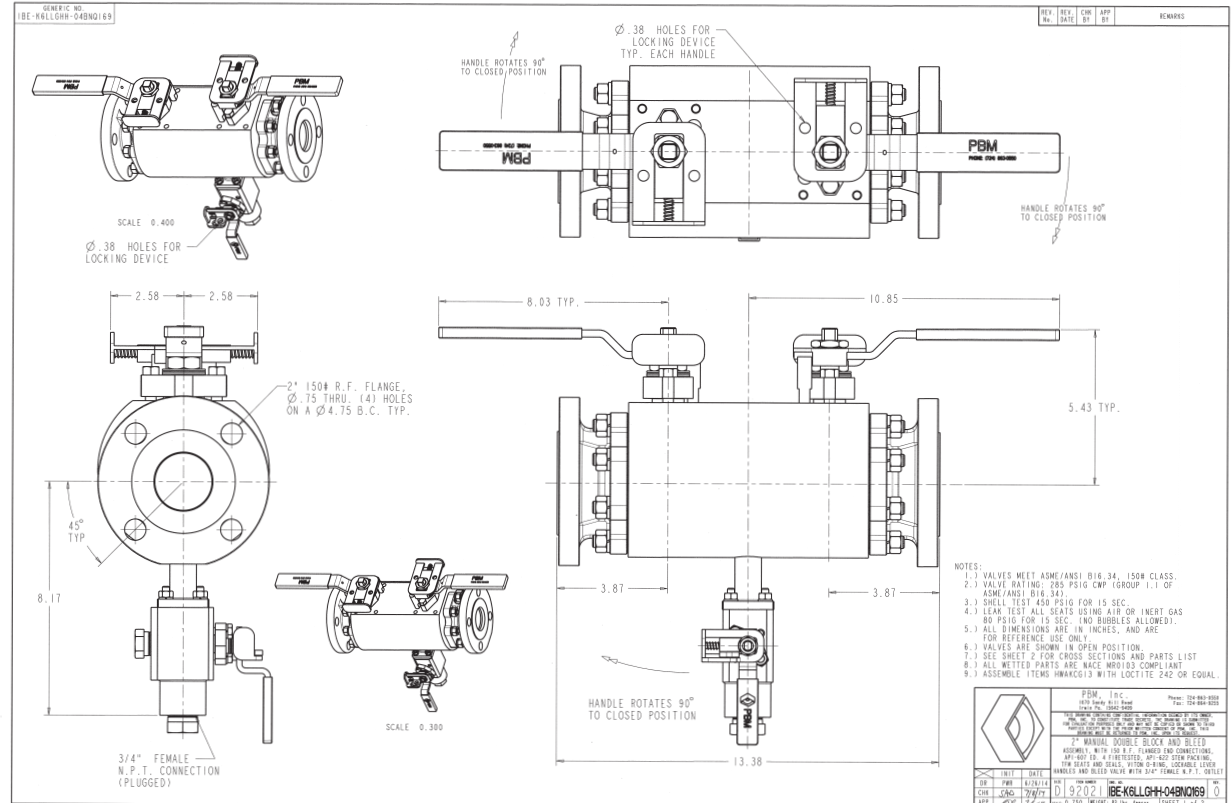

1070 SANDY HILL ROAD, IRWIN, PA 15642 USA
 1-800-967-4PBM
 WWW.PBMVALVE.COM
 INFO.PBMVALVE@IMI-CRITICAL.COM

