



APPLICATION BRIEF - 19/0805

INDUSTRY: PETROCHEMICAL
PRODUCT: TRANSMITTER ISOLATION VALVE
MEDIA: PETROCHEMICALS

IMI PBM Solution:

A major International petrochemical company was looking for a triple-redundant method of isolating transmitters used to provide vital feedback on petrochemicals stored in tanks. The valves required to insolate transmitters had to be fire rated and capable of providing a tight shutoff against corrosive and high-temperature petrochemicals. Each assembly contained 3 transmitter isolation valves, each with 2 fire-rated valve on the purge connections to facilitate cleaning the valve bodies and calibrating the transmitters.

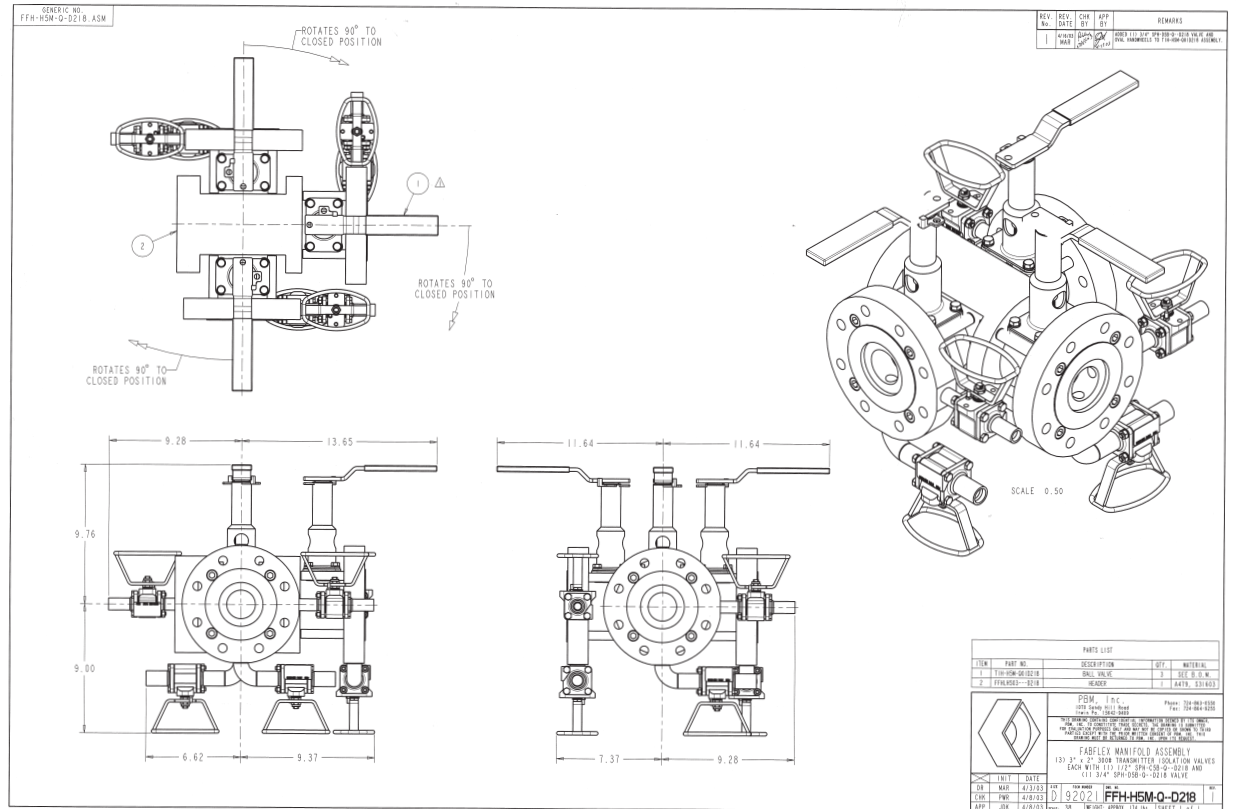

1070 SANDY HILL ROAD, IRWIN, PA 15642 USA
 1-800-967-4PBM
 WWW.PBMVALVE.COM
 INFO.PBMVALVE@IMI-CRITICAL.COM

