



APPLICATION BRIEF - 33/0906

INDUSTRY: PETROCHEMICAL

PRODUCT: INSTRUMENT ISOLATION - ROOT VALVE

MEDIA: OIL, SAND, SALTWATER

IMI PBM Solution:

A Major Petroleum company required an instrument root valve for use on an offshore platform. Over 600 valves were required to isolate critical instruments and gauges from process flows containing a mixture of oil, sand, and seawater. PBM designed and supplied valves with stellite seats to handle the abrasive, erosive, and corrosive environment.

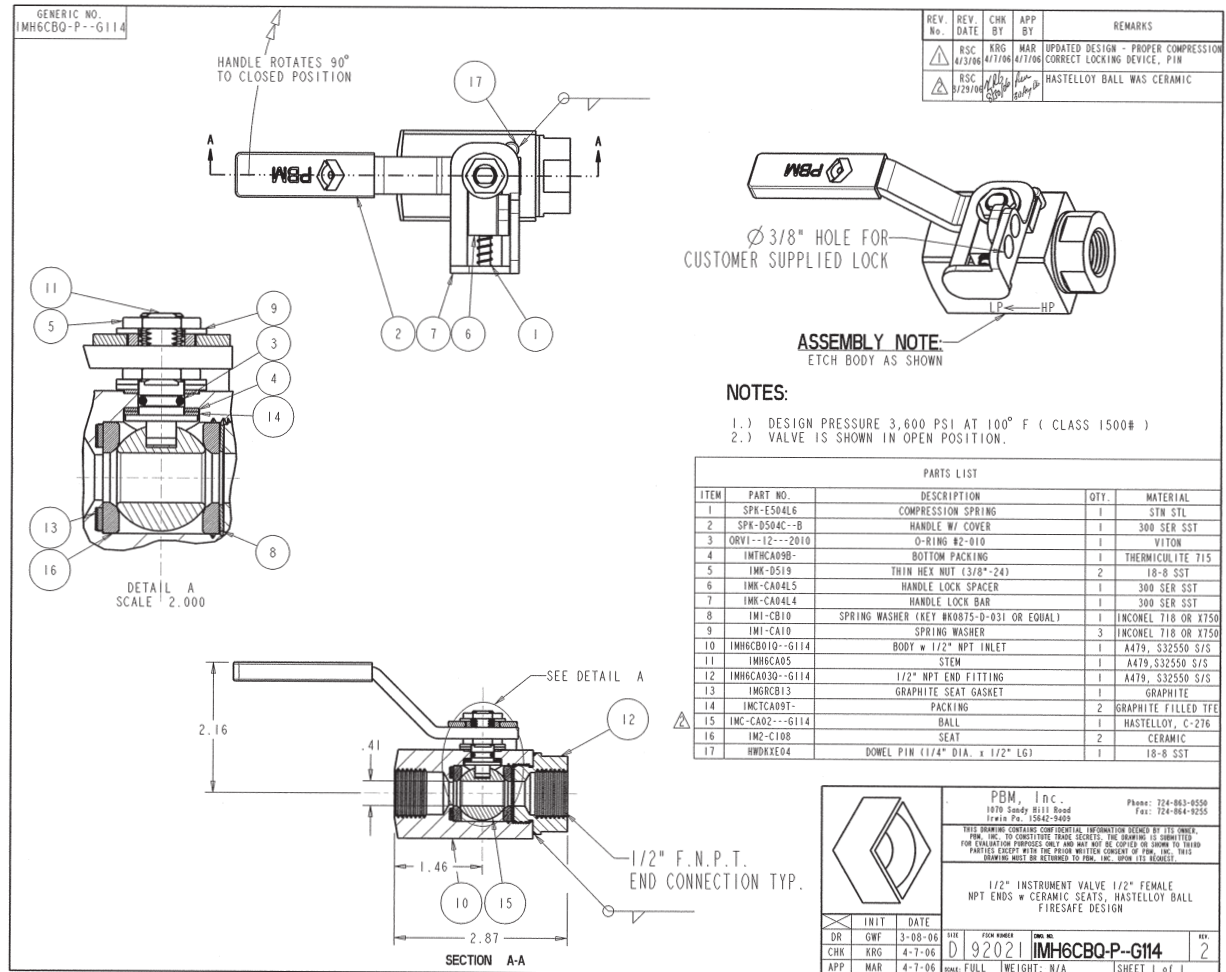

1070 SANDY HILL ROAD, IRWIN, PA 15642 USA
 1-800-967-4PBM
 WWW.PBMVALVE.COM
 INFO.PBMVALVE@IMI-CRITICAL.COM

