



# APPLICATION BRIEF - 61/0111

**INDUSTRY:** REFINING

**PRODUCT:** TRANSMITTER ISOLATION VALVE

**MEDIA:** ISOLATION OF ELECTRONIC TRANSMITTERS

## IMI PBM Solution:

A major Northwestern US refinery producing various grades of gasoline, jet fuel, and diesel fuel required quality and dependable valves for isolation of electronic transmitters (differential pressure). PBM supplied it's Transmitter Isolation valves rated to ANSI Class 300# and 600# with carbon-graphite seats for higher temperature applications to 650°F and with TFM seats for lower temperature applications between 150°F to 325°F.

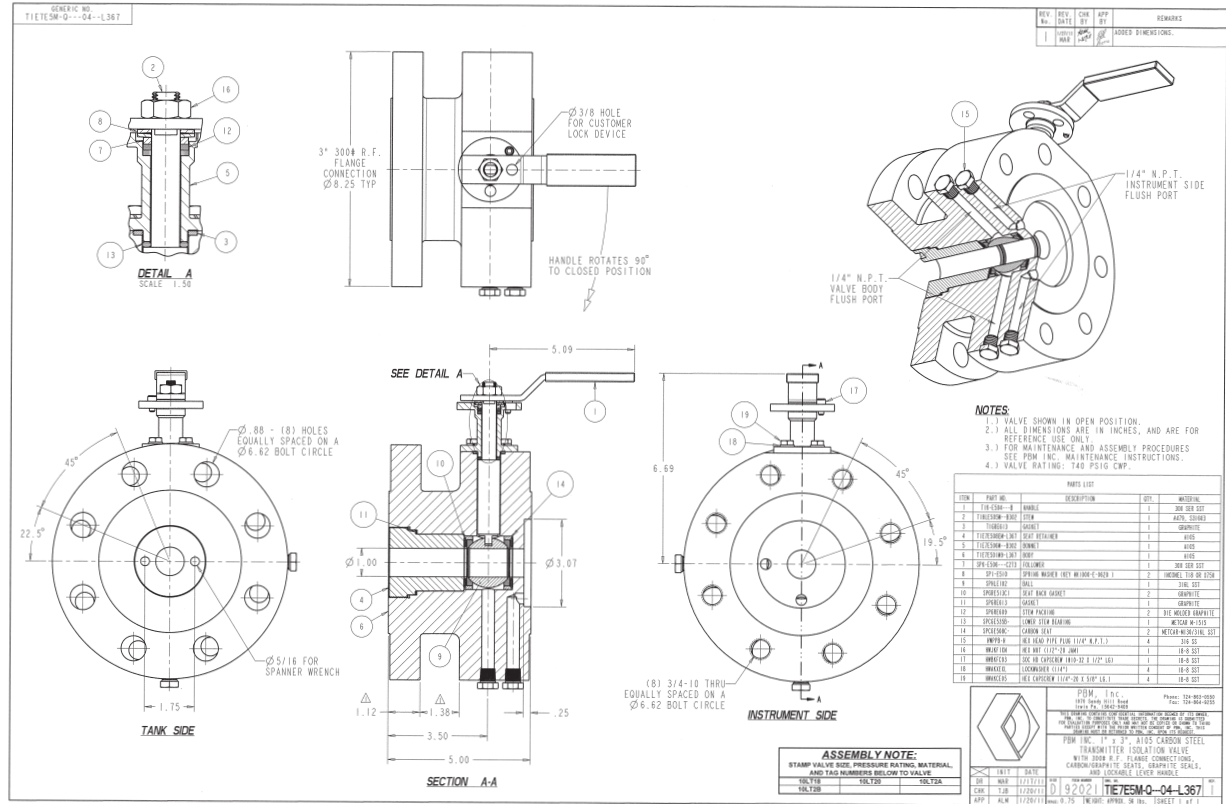

1070 SANDY HILL ROAD, IRWIN, PA 15642 USA  
 1-800-967-4PBM  
 WWW.PBMVALVE.COM  
 INFO.PBMVALVE@IMI-CRITICAL.COM

