



APPLICATION BRIEF - 95/0712

INDUSTRY: REFINING

PRODUCT: PBM FABFLEX® MANIFOLDS WITH TRANSMITTER ISOLATION VALVES

MEDIA: HYDROCARBONS

IMI PBM Solution:

Major refinery needed a way to reduce space, control the fabrication process, reduce emissions and simplify field installation while providing for redundant level transmitter mounts at the top of their stripper columns. PBM provided a Fabflex® fabricated manifold to solve the problems. The Fabflex® manifold is factory fabricated in a controlled manufacturing environment, ensuring high quality welds and allowing for optimal space utilization. By replacing the old system of multiple flanges and individual valves with valves fabricated “into” the manifold, many emission leak paths were eliminated to improve the overall EPA rating of the system. Field installation was simplified into bolting up one flange and installing the transmitters.

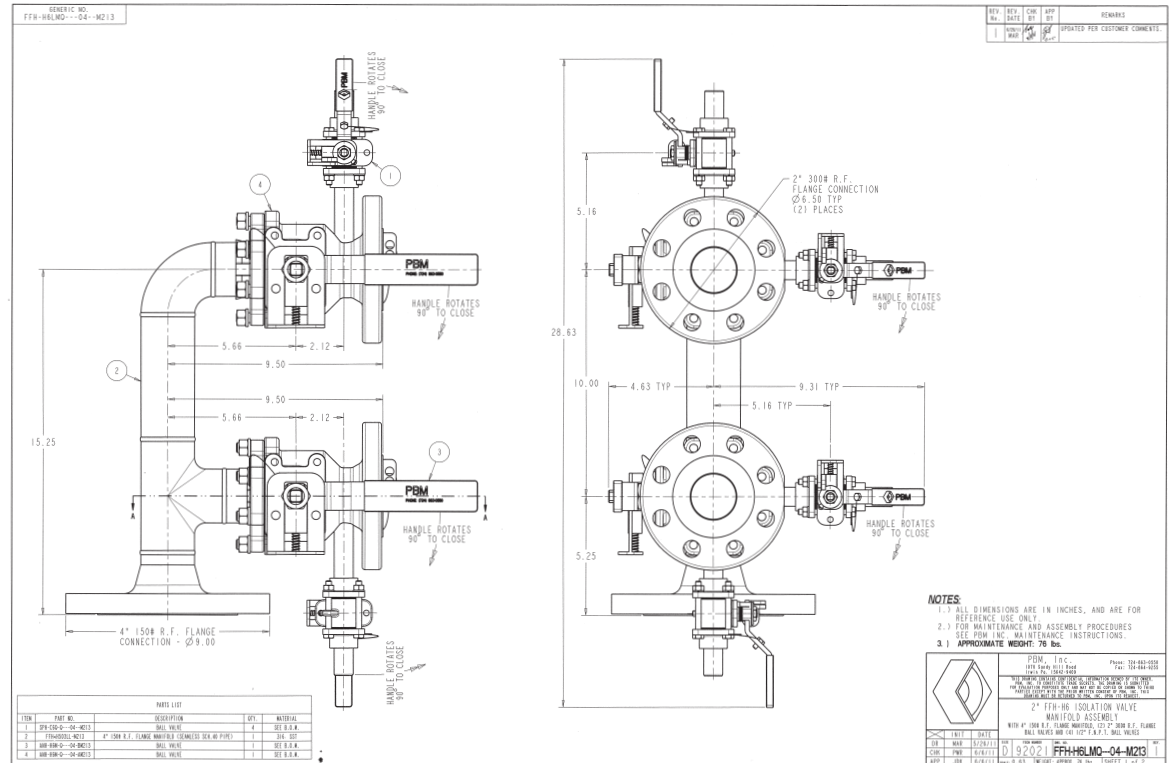

1070 SANDY HILL ROAD, IRWIN, PA 15642 USA
 1-800-967-4PBM
 WWW.PBMVALVE.COM
 INFO.PBMVALVE@IMI-CRITICAL.COM

