

WARNING:

For your safety and protection it is important that the following precautions be taken prior to working on the actuator.

1. Remove from the actuator all dust that may cause sparks; clean periodically to prevent dusting on the actuator. Do not hit the actuators with metallic objects, as they may give off sparks.
2. The installation and the maintenance of pneumatic actuators must be assigned to trained and qualified personnel.
3. The use of the actuators out of the allowed temperature and pressure ranges may cause damage to the internal and external components.
4. Prior to any installation and maintenance of the actuator, close and disconnect any kind of power or air supply.
5. Disassembling the spring return type actuators (springs inside) may cause severe injuries. The maintenance must be assigned to qualified expert personnel in full observance of the instruction described at paragraph 5, otherwise, the actuator has to be returned to PBM.

TABLE OF CONTENTS:

1. SERVICE CONDITIONS
2. FUNCTION
3. STORAGE
4. MAINTENANCE
5. EXPLODED VIEW
6. DISASSEMBLING
7. ASSEMBLING
8. ADJUSTMENT
9. INSTRUCTIONS FOR CHANGING FAIL CLOCKWISE OR FAIL COUNTERCLOCKWISE OPERATION
10. TORQUE RATINGS, WEIGHTS AND OPERATION VOLUMES

1 Service conditions

- **AIR SUPPLY:** dehumidified or lubricated air (standard). Other non-corrosive gases or fluids are a possible alternative option, if compatible to the materials of the actuator components (internal parts and lubricant). The maximum particle size must not exceed 40µm (ISO 8573 Part 1, Class 5). In order to prevent water condensation and/or solidification (ice, when actuator work below 0°C), the operating medium must have a dew point equal to 20°C or, at least 10°C below the ambient temperature (ISO 8573 Part 1, Class 3).
 - **WORKING PRESSURE:** minimum 29 PSI (2.5 BAR) – maximum 116 PSI (8 BAR)
 - **TEMPERATURE:**
 - minimum -20°C to maximum + 85°C - standard execution – NBR gaskets
 - minimum -20°C to maximum + 150°C - HIGH temperature execution – FKM (Viton) gaskets
 - minimum -40°C to maximum + 85°C - LOW temperature execution – silicone gaskets
 - Warning: in case of high or low temperature executions, a special grease is used as lubricant and such conditions may alter the torque generated by the actuator. For further information please refer to PBM.
 - **ROTATION:** half turn, 0° – 90° adjustable ±5° in both end positions (double adjustment).
 - **LUBRICATION:** The actuators are equipped with filled-for-life lubrication for normal service conditions.
 - **OPERATING TIME:** Please refer to the technical documentation. The operating time depends on various parameters such as air supply pressure, capacity of the air supply installation (size of piping, control equipment), type of valve and fluid, selected safety factor, temperature, etc.).

2 Function

The air pressure acts on the surface of the pistons (12) causing their alternate movement, which is converted into rotation (standard 90°) of the pinion (2) as a result, the pneumatic actuators can be used for remote operation of valves.

2.1 Double Acting

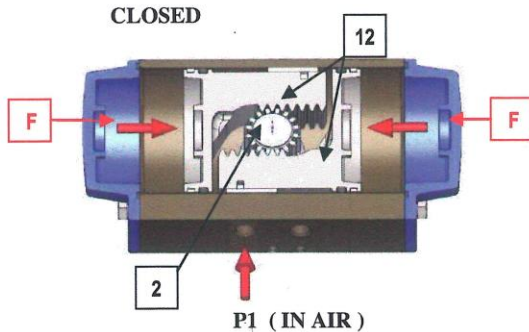

Supplying air through port **P1**, the external chambers fill up and the pressure on the surface of the pistons (12) creates a force (**F**) pushing them close to the pinion, generating a torque with **CLOCKWISE** rotation. (top view)

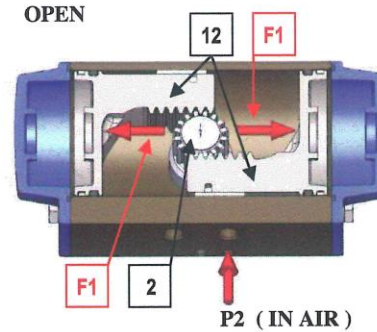

When the pistons (12) are close to the pinion, supplying air through port **P2** the internal chamber fills up and the pressure on the surface of the pistons creates a force (**F1**) pushing them away from each other, generating a torque with **COUNTERCLOCKWISE** rotation (top view).

2.2 Spring return

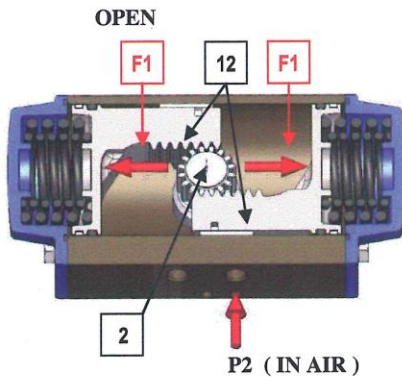

Supplying air through port **P2**, the internal chamber fills up and the action of the pressure on the surface of the pistons (12) creates a force (**F1**) pushing them away from each other, generating a torque with **COUNTERCLOCKWISE** rotation. (top view)

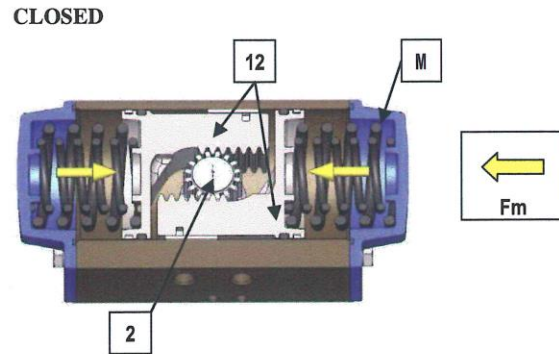

The springs (**M**) are now compressed. Terminating the supply of air through port **P2** the **springs (M)** start extending and apply a force (**Fm**) pushing the pistons (12) close to the pinion, generating a torque with **CLOCKWISE** rotation. (top view).

3 Storage

It is recommended that the actuator be kept in clean and dry place. The state of preservation during the storage time is improved if the actuator is preserved in the original packing box.

For a **long storage period** we recommend to effect periodically one complete cycling by pressurizing the chambers.

The actuators have two air ports which should be plugged during storage to avoid any intrusion

4 Maintenance

The maintenance of the actuator is permitted to Valbia personnel or to properly trained personnel. Valbia supplies the spare parts (gaskets, guide elements) in appropriate kits (except for lubricating grease). The maintenance may become necessary between 500.000 and 1.000.000 cycles, according to the local service conditions.

5 Exploded View

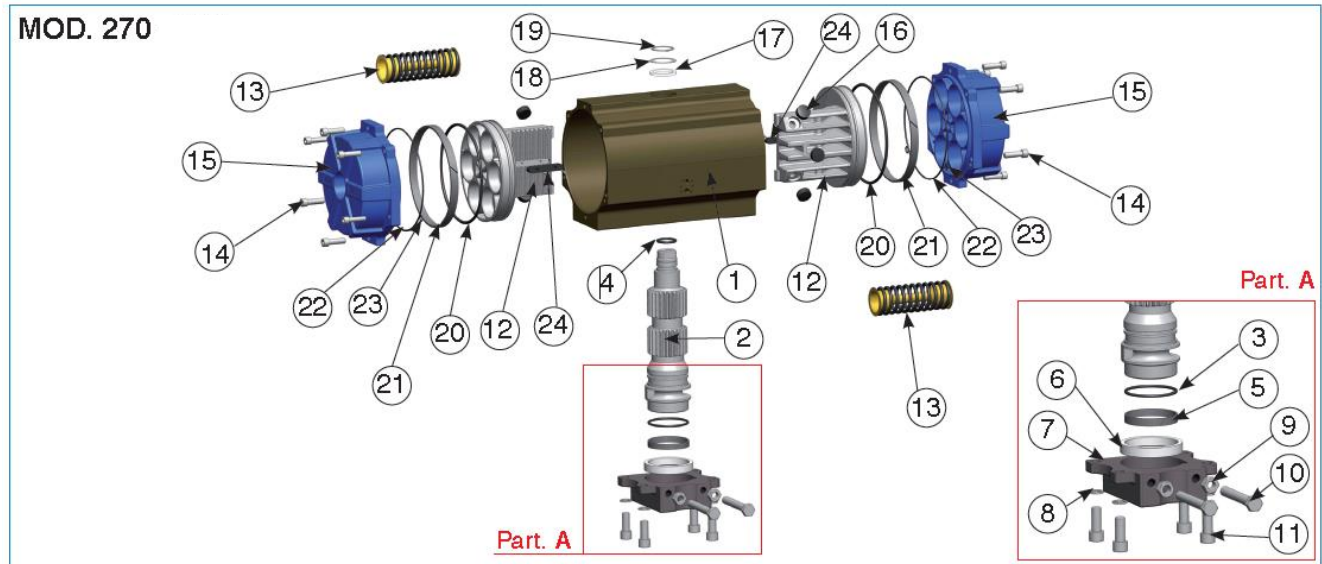

POS.	Description	Material	DA	SR
1	Body	Extruded Aluminum	1	1
2	Anti-blowout pinion	Steel	1	1
*3	O-ring	NBR	1	1
*4	O-ring	NBR	1	1
*5	Anti-Friction Ring	PTFE 15% Graphite	1	1
*6	Anti-Friction Ring	PTFE	1	1
7	Plate	GGG40	1	1
8	Washer	Stainless Steel	4	8
9	Stop Bolt Retaining Nut	Stainless Steel	2	2
10	Stop Screw	Steel	2	2
11	Fixing Screws	Stainless Steel	4	4
12	Piston	Die Cast Aluminum	2	2
13	Pre-Compressed Spring	Steel	0	*****
14	End Cap Fixing Screw	Stainless Steel	12	12
15	End Cap	Die Cast Aluminum	2	2
*16	Thrust Block	POM	6	6
*17	Spacer Ring	POM	1	1
18	Pinion Washer	Stainless Steel	1	1
19	Snap Ring	Steel	1	1
*20	O-ring	NBR	2	2
*21	Anti-Friction Ring	PTFE 15% Graphite	2	2
22	O-ring	NBR	2	2
23	O-ring	NBR	4	4
24	Anti-Blowout Key	POM	2	2

* Part subject to wear

Number of springs for each side –
 60 PSI Spring Return is 4/5 (Spring Set 05)
 80 PSI Spring Return is 6/6 (Spring Set 08)



6 Disassembling

6.1 Disassembling mod. 0270

CAUTION : It is recommended to use suitable safety equipment during the handling for maintenance because of heavy and/or bulky parts.

1. Disconnect pneumatic and electric supplies from the actuator;
 2. After having disconnected their power supply, remove carefully any accessory attached to the actuator, preventing any damage during the handling;
 3. Detach the actuator from the valve taking careful note of all references that may be helpful for the attachment after maintenance.
 4. Place the actuator on a support with a square of the same size of the pinion (2) so as to easily execute the below listed operation (see Fig. 6);
 5. Before disassembling the actuator check from the label on the body whether it is a double acting (DA) or spring return (SR) type;
 6. For DOUBLE ACTING ACTUATOR: Unscrew in crossed sequence the screws (14) for fastening the end caps (15) see Fig. 7
 7. For SPRING RETURN ACTUATOR: Unscrew GRADUALLY in crossed sequence the screws (14) for fastening the end caps (15), Fig. 7; Note: the screws are long enough to hold the pre-compressed springs (13) even if extended; Loosen nuts (9) and unscrew completely screws (10) see Fig. 8 ;
 8. Rotate the cylinder (1) in CLOCKWISE direction (top view) holding the pinion (2) so as to release the rack of the pistons (12) from the pinion (2) and to push the pistons towards to the cylinder ends. Now both pistons (12) can be removed see Fig. 9.
- NOTE: Do not use compressed air to remove the pistons (12) from the cylinder (1)
9. Lay the actuator on one base of its cylinder (1) and unscrew the screws (11) in crossed sequence to remove the plate (7) see Fig. 10 ;
 10. Place the actuator on the support again.
 11. Remove the snap ring (19) from the pinion (2), the washer (18), and the spacer (17), See Fig. 11.
 12. Gradually raise the cylinder (1) making sure that the pinion (2) gets extracted with special caution for all seatings (if necessary, use a rubber hammer), see Fig. 12..

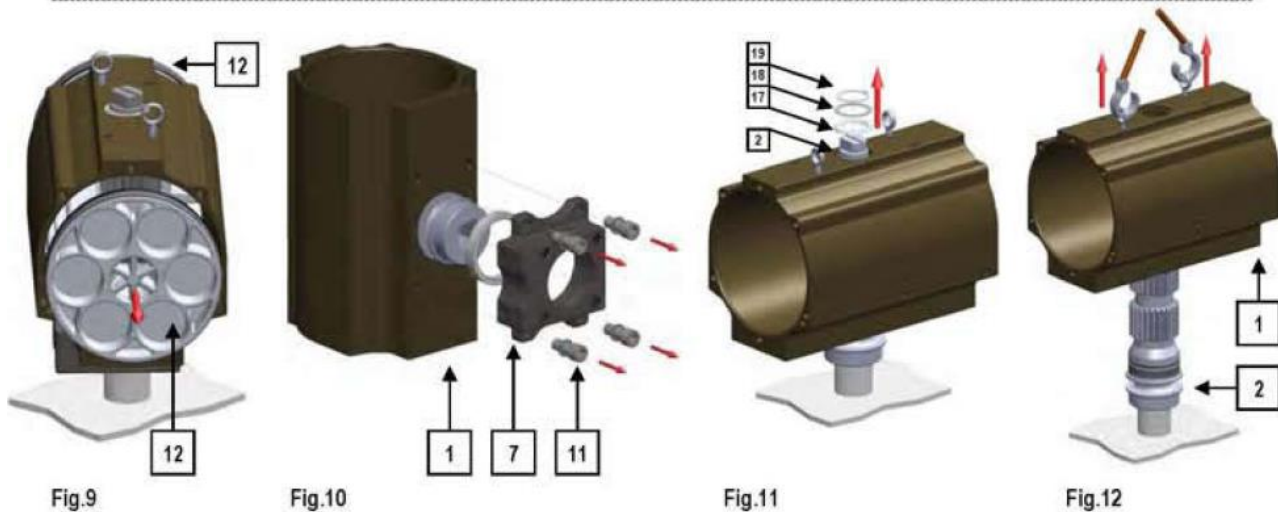
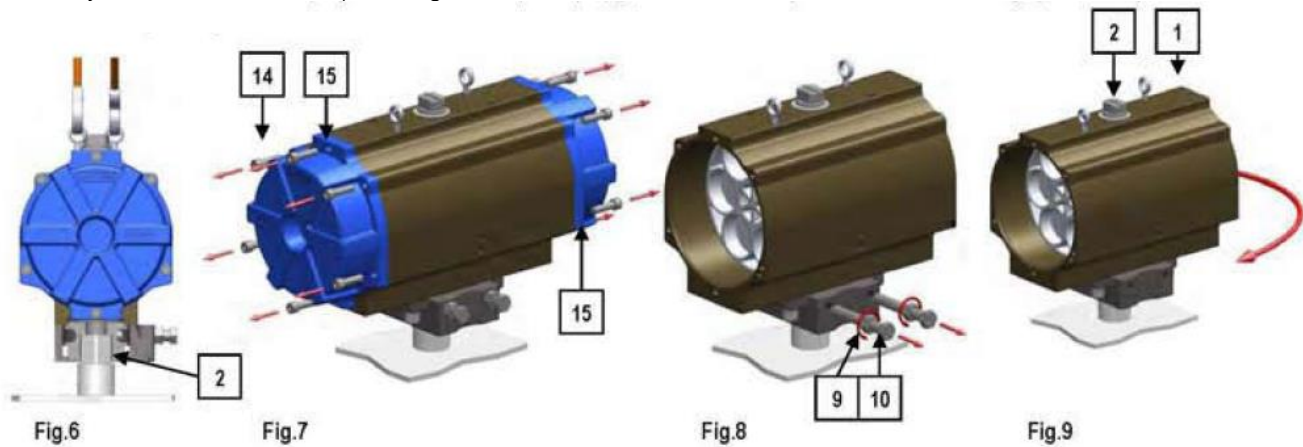

7 Assembling

7.1 Assembling mod. 0270

CAUTION: It is recommended to use suitable safety equipment during the handling for maintenance because of heavy and/or bulky parts.

1. Before assembling clean all components preferably with degreaser.
 2. Place the pinion (2) on a support with a square of the same size of the female attachment. Make sure that the pinion is provided with lower O-ring (3), spacer (5) and upper O-ring (4). Lubricate the O-rings (see arrows fig. 19). The recommended lubricating grease is "KLUBER" TRIBO STAR 1EP"
 3. Lay the cylinder (1) down on the pinion (2), see fig. 20.
 4. Fit on the pinion (2) the spacer (17), the washer (18), the snap ring (19), see Fig. 21.
 5. Remove the cylinder with pinion from the support and lay it on one base to mount the plate (7) with anti-friction ring (6) (holes for adjusting screws on the same side as the NAMUR attachments), then screw down the fastening screws (11) with washer (8) in crossed sequence, see fig. 22, and place the cylinder on the support again.
 6. Grease the internal chamber of the cylinder (1) and both pistons (12) provided with O-ring (20), antifriction ring (21), anti-blowout key (24), and thrust block (16). The recommended lubricating grease is "KLUBER" TRIBO STAR 1EP".
 7. Rotate the Cylinder (1) by approx.. 50° to the upper slot of the pinion, see fig. 23.
 8. For the standard execution (clockwise rotation opens) press the pistons (12) into the cylinder (1) while turning the cylinder (1) in counterclockwise direction (top view) until the pistons come into contact, see fig. 23, 24 ;
 8. Introduce the adjustment screws (10) with nuts (9) into the plate (7) and adjust the travel stop, see fig. 25 and paragraph 8;
 9. For DOUBLE ACTING ACTUATOR: Mount the end cap (15) with O-ring (22) and gasket (23) on the cylinder and screw down in crossed sequence the screws (14), see fig. 26. Repeat the operation on the opposite side.
- For SPRING RETURN ACTUATOR: Introduce the spring sets into the cylinder (1) and center them in the appropriate pockets of the piston (12), then mount the end caps (15) with O-ring (22) and gaskets (23) **Note: the pistons have to be in CLOSED position.** Screw partially down the screws (14) in crossed sequence compressing the springs uniformly until the cap is completely closed, see fig. 26. Repeat the operation on the opposite side;
10. Execute some test cycles to check the correct functioning of the actuator before installing it.

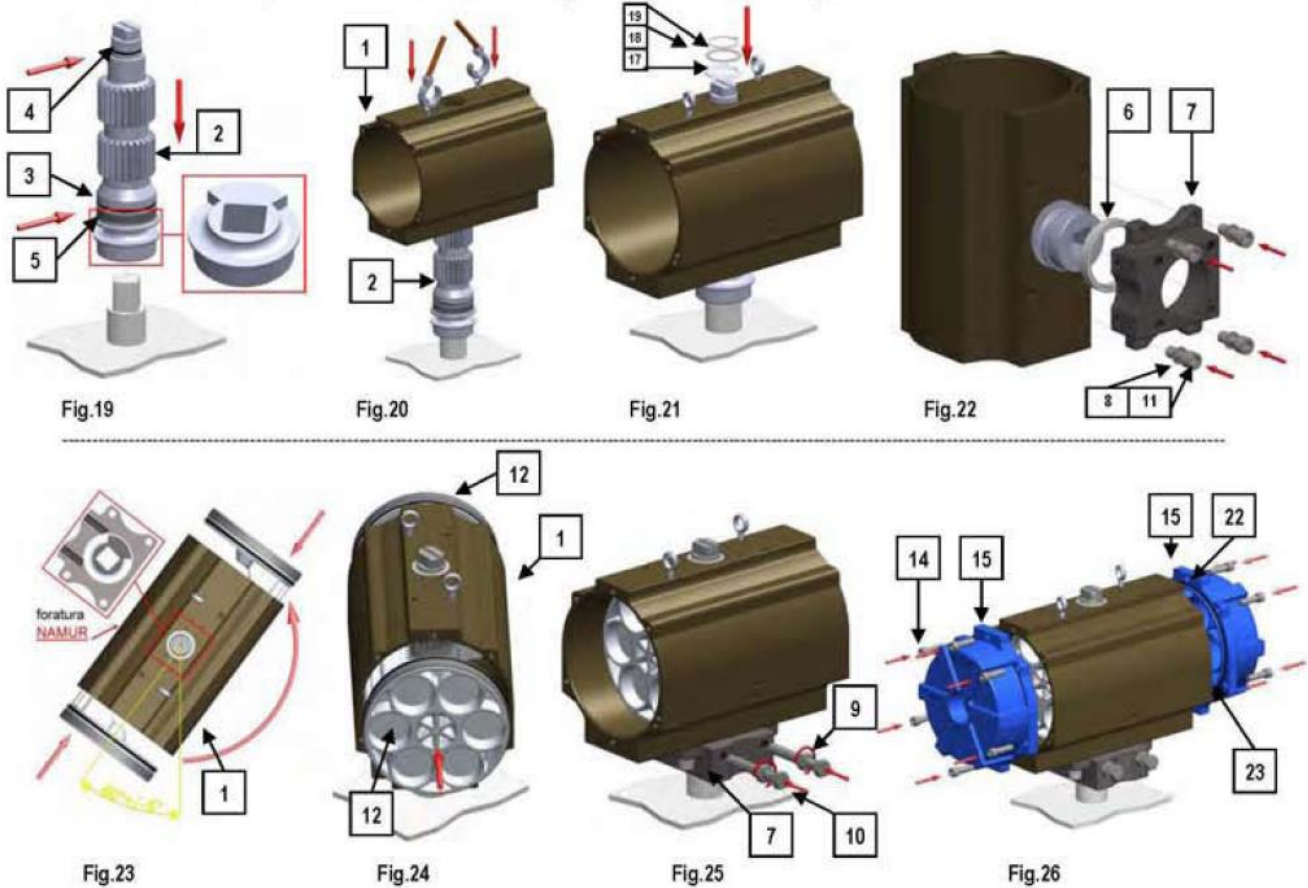

8 Adjustment

By means of the left screw the 90° end position (open) can be adjusted, see Fig. 27, of the right screw the 0° end position (closed), see Fig. 28.

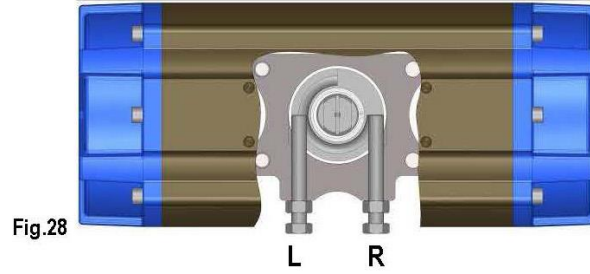
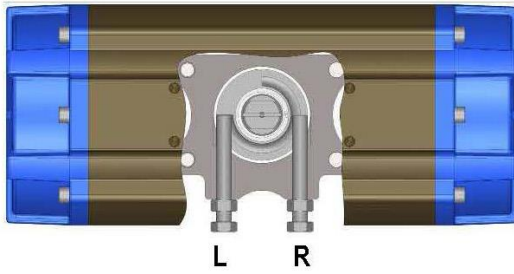
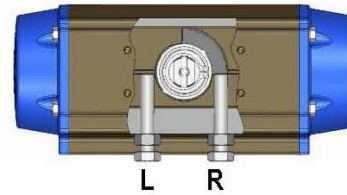
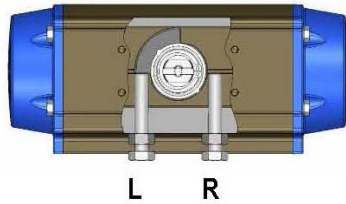

Fig.27

Fig.28

NOTE : During the adjustment the pinion must not be blocked on the support.

8.1 Adjustment procedure, actuator in **counter clockwise position.**

- Put the actuator in **clockwise position**
- **Adjust** by means of the left adjustment screw (L)
- Put the actuator in **counter clockwise** position and check the adjustment
- Repeat until the desired adjustment is achieved
- Hold the screw in the correct position and tighten the nut.

8.2 Adjustment procedure, actuator in **clockwise** position

- Put the actuator in **counter clockwise** position (supply compressed air for mod SR);
- **Adjust** by means of the right adjustment screw (R);
- Put the actuator in **clockwise** position and check the adjustment (interrupt the air supply for mod.SR);
- Repeat until the desired adjustment is achieved;
- Hold the screw in the correct position and tighten the nut.

9. Instructions for Changing Fail Clockwise or Fail Counterclockwise Operation of Pneumatic Actuators

WARNING:

For your safety and protection it is important that the following precautions be taken prior to working on the actuator.

1. Remove from the actuator all dust that may cause sparks; clean periodically to prevent dust on the actuator.
2. The installation and the maintenance of pneumatic actuators must be assigned to trained and qualified personnel.
3. Prior to any installation and maintenance of the actuator, close and disconnect any kind of power or air supply.
4. Disassembling the spring return type actuators (springs inside) may cause severe injuries.

1. Instruction

- 1.) Depressurize actuator and disconnect air supply and any accessories that are attached to the actuator.
- 2.) Remove the actuator from valve.
- 3.) Remove fasteners that attach the end caps to the actuator body. These will be difficult to turn at the beginning because the springs are pushing against the end caps. Do this in a staggered fashion, taking care to make sure that the end caps stay straight as they move away from the actuator body. The fasteners will stay engaged in the actuator body until the spring load is completely gone. Then remove the end caps from the body. There are rubber seals between the end caps and the body, make sure that they stay in the grooves in the end caps.
- 4.) Back out the travel stops until they are no longer visible when looking down thru the passages in the actuator body.
- 5.) Turn the actuator shaft with a wrench, this will back the pistons out of the actuator body.
- 6.) Remove the pistons from the actuator body, noting which

side of the pinion that each was engaged by each piston.

7.) Using a wrench, rotate the actuator shaft back to its original position.

8.) Re-install the pistons in the actuator. Note that they will be inverted from their original location. If the right hand piston engaged on the front of the pinion, it now must engage on the back of the pinion.

9.) Push the pistons into the body using hand force only until they engage with the pinion.

10.) Turn the pinion with a wrench to make sure that both pistons are engaged with the pinion and make sure that each piston is an equal distance from the end of the actuator. If distances are not the same, remove both pistons and reinstall.

11.) Re-install the springs into the actuator in their original locations and reinstall the end caps. Make sure that the threads on the long fasteners are clean and well lubricated before re-installing.

12.) Tighten the fasteners equally, making sure that the end caps come down equally and straight.

13.) Test actuator travel and function, re-install on valve and reset travel stops.

This is Normal Fail Close Operation –
Note the location of the Piston Racks
 Right Piston Rack is in Front – Just Behind Air Supply Parts

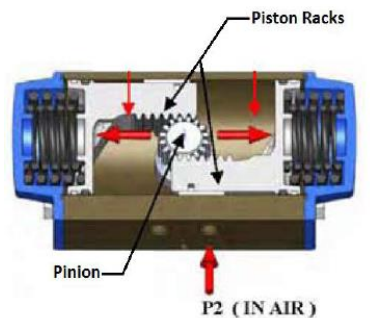

This is Normal Fail Open Operation –
Note the location of the Piston Racks
 Left Piston Rack is in Front – Just Behind Air Supply Parts

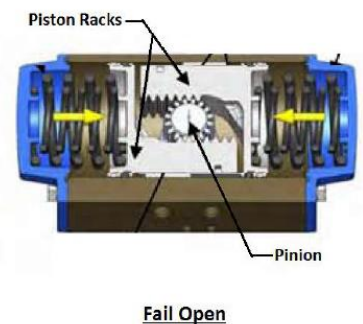
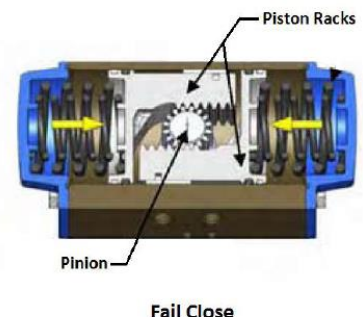
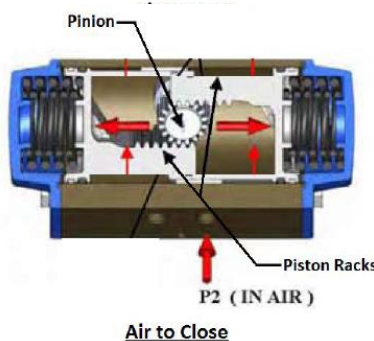

10 Torque Ratings, Weights and Operation Volumes

SPRING RETURN ACTUATORS

Actuator Model	Spring Set	Spring Torque Output (in-lbs)		Air Pressure at Actuator (psig)			
				60		80	
		Start	End	Start	End	Start	End
PAVCL253S - -0270	5	10,788	6,915	11,495	6,884	N/A	N/A
PAVCL453S - -0270	8	14,387	9,230	N/A	N/A	15,360	9,220

WEIGHTS AND VOLUMES

Actuator Model	Rotate CCW Volume (cu.in.)	Rotate CW Volume (cu.in.)	PVC series Approx. weight (lbs)
PAVCL453D - - 0270	915	1,086	222
PAVCL453S - - 0270	915	946	269

DOUBLE ACTING ACTUATORS

Actuator Model	Air pressure at actuator (psig)	
	60 psig	80 psig
	Constant Torque Output	
PAVCL453D - - 0270	19,097	25,469



1070 Sandy Hill Road, Irwin, PA 15642

Phone: (724) 863-0550 or (800) 967-4PBM Fax: (724) 864-9255

E-mail: info.pbmvalve@imi-critical.com Web: www.pbmvalve.com

© Copyright 2020 PBM, Inc. IOM-ACTUATOR-C-270 R1 11/20 Printed in USA

