

# Installation, Operation, and Maintenance Instructions for Class 600, CN Series 6 Cryogenic Valves, 1/2" thru 6" Reduced Port



## **WARNING:**

For your safety and protection, it is important that the following precautions be taken prior to and while work on the valve.

1. Depressurize and drain the line.
2. Cycle the valve to relieve any pressure trapped in the valve.
3. Disconnect any air and electrical connections to the valve assembly.
4. Determine what type of media is in the line and wear appropriate protective clothing and equipment. Obtain the appropriate MSDS sheets.
5. To ensure safe product selection and operation, it is the responsibility of the process system designer and end user to determine the appropriate compatible materials of construction and adequate product ratings for the process system. Process system designer, installer, and end user are responsible for proper installation, operation, and maintenance.
6. When disposing of Teflon parts, do not incinerate or subject to open flames.
7. Special precautions should be taken for valves that are to be cleaned for oxygen service. Consult standard on-site practices for oxygen service valve maintenance.

### 1. General

This Installation, Operation, and Maintenance manual is for the safe use of PBM 2-piece, Class 600, CN Series 6 Reduced Port, Cryogenic ball valves. Please read the instructions carefully and save them for future reference.

### 2. Installation

The Class 600, CN Series 6, Reduced Port Cryogenic valves are unidirectional with the vent hole in the upstream side of the ball, and therefore, must be installed according to the direction of the flow arrows etched onto sides of the valve body. It is recommended that the valve be in the closed position during installation and initial cool-down.

### 3. Operation

For manual valves, operation consists of turning handle 90° to either close or open the valve. The valve is in the open position when the handle is parallel with the pipeline. These valves may also be automated with actuators and other valve automation equipment. Mechanical handle stops must be removed if manual valves are converted to automated valves. For automated valves, operation is controlled by the actuator placed on top of the valve. Valve stops are an integral part of the actuators. Good operating procedure requires periodic inspection of the valves and replacement of parts as required. Always use PBM factory authorized replacement parts.

### Locking Handle Device, manual valves only

1. Depress handle lock bar inward toward the valve stem until it clears the stop on the valve gland plate.
2. While maintaining the handle lock bar in this position, turn handle to desired position.
3. Release the handle lock bar, ensuring that it returns to the proper position against the handle.

Follow instructions to ensure optimum performance:

### Adjusting for Normal Wear

1. If the valve shows signs of leakage between the body and either the bonnet or end fitting, the gasket(s) require replacement.
2. If the valve shows signs of leakage in stem area due to normal stem packing wear, tighten the four gland plate bolts (ensuring the gland plate is level), then loosen the upper jam nut on the stem, then tighten the lower jam nut as follows:
  - a.) For valves 2" and smaller, tighten nut to completely compress spring washers, then loosen nut ½ turn.
  - b.) For valves 3", tighten nut until a gap of about 0.05" (1.3 mm) exists between the adjacent spring washers.
  - c.) For valves 4" and larger, tighten the nut until a gap of about 0.10" (2.5 mm) exists between the adjacent spring washers.
3. Re-tighten the upper jam nut. Leakage should stop, and the valve should continue to operate smoothly.
4. If packing leakage cannot be stopped, a repair kit will be required.

PARTS LIST	
ITEM	DESCRIPTION
1	Lower Stem Packing
2	Locking Handle Spring (Manual Only)
3	Locking Handle Spacer (Manual Only)
4	Locking Handle Lock Bar (Manual Only)
5	Thin Stem Hex Nut
6	Stem Spring Washers
7	Follower
8	End Fitting Fastener
9	Grounding Lug
10	Stem Hex Nut
11	Body Lock Washers
12	Bonnet/Gland Plate Lock Washers
13	Gland Plate Fasteners
14	Ground Wire Fastener
15	Bonnet Fasteners
16	End Fitting Hex Nut
17	Stem
18	Bonnet
19	Ball
20	Handle
21	Stop Pin (Manual Only)
22	Gland Plate
23	Upper Stem Packing
24	End Body Gasket
25	Seat Back Gasket
26	End Fitting
27	Body
28	Bonnet Gasket
29	Seat
30	Grounding Spring
31	Grounding Wire
32	Dowel Pin (if Supplied)

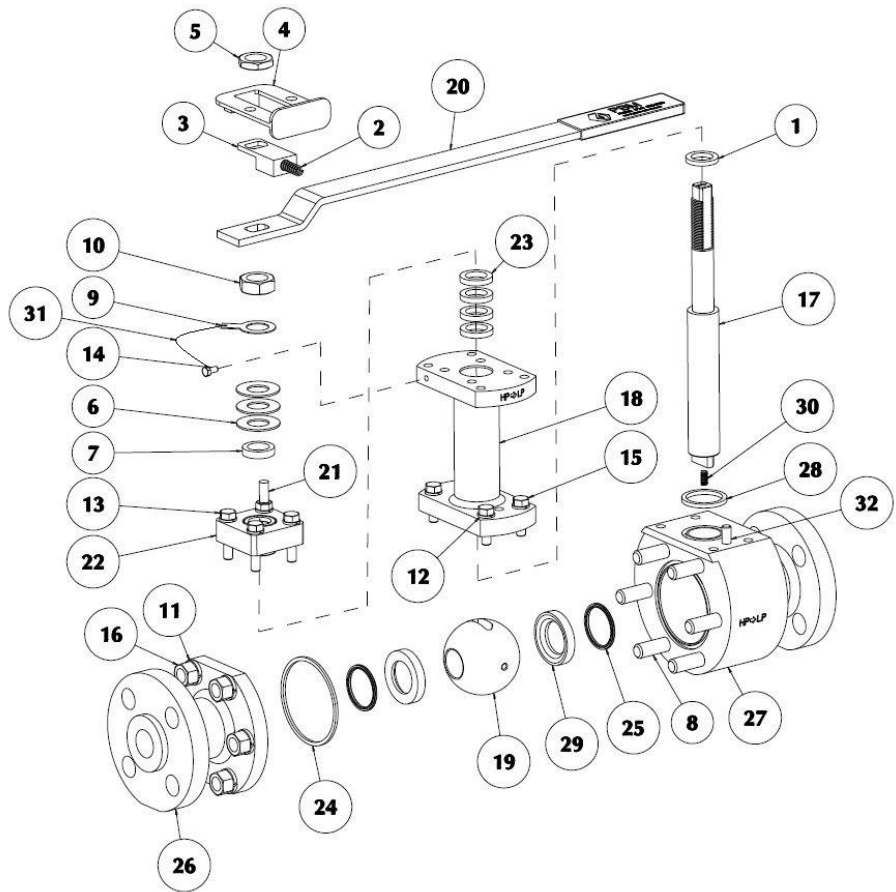

### Disassembly of valve:

1. Isolate and depressurize the associated piping system. Cycle the valve to ensure there is no trapped pressure or fluid in the valve cavity. The valve should be left fully open or fully closed. Remove insulation, if any.
2. **For Automated Valves Only:** Remove all air and electrical power from the actuator, solenoid valve, and switchbox, if any. Then remove the automation assembly from the valve. Retain coupling and mounting bracket.
3. **For Manual Valves Only:** Loosen and remove the upper jam nut from the stem and then remove the handle and lock components.
4. Loosen and remove the flange bolting and remove the valve from the piping.
5. Remove the end fitting hex nuts or fasteners, lock washers, and tag, if equipped.
6. Pull the end fitting free from the body. It may require force to remove.
7. Remove the seats and seat back gaskets from the end fitting and body.
8. Remove the body gasket from the body. If the valve is equipped with graphite gaskets, carefully remove them from the body with a hook or pick type hand tool. Take care not to scratch or otherwise damage the gasket grooves in the body.
9. Rotate the stem to orient the ball to the closed position. Slide the ball out, taking care not to nick or scratch the ball. Remove ground spring from the hole in the bottom

of the stem.

10. Loosen and remove the upper jam nut from the stem. Remove the handle, remaining jam nut, spring washers, follower and ground wire terminal.
11. Loosen and remove the gland plate fasteners and lock washers, then remove the gland plate from the bonnet.
12. Loosen and remove the bonnet fasteners and lock washers, then pull the bonnet away from the body.
13. Remove the bonnet gasket from the body. If the valve is equipped with graphite gaskets, carefully remove them from the body with a hook or pick type hand tool. Take care not to scratch or otherwise damage the gasket grooves in the body.
14. Push the stem into the bonnet and out the bottom of the bonnet. The bottom packing may come off with the stem. If not, reach into the bonnet counterbore and remove.
15. Remove the top packings from the bonnet.

## Reassembly of valve:

1. Before reassembling the valve, examine all parts. Replace any worn or damaged parts. PBM recommends using new seats, seals, and gaskets upon each disassembly and reassembly.

 **Warning: All valve components must be LOX cleaned and inspected prior to reassembly of the valve in a “clean room” type environment. Failure to do so may create a hazardous operating environment which may result in fire, explosion, and/or bodily harm. Proper LOX cleaning, assembly, installation, and operation are the sole responsibility of the customer or end user.**

2. Insert a new lower stem packing on the stem such that the packing seats on top of the ledge on the stem. This packing should be white in color.
3. Insert the stem into bottom of the bonnet bore and up through the top of the bonnet.
4. Install the upper stem packings over the stem. Push the packings into the bonnet counterbore. Making sure that when installing the packing, if it has a diagonal split, to install the cut 90° from the previous split.
5. Install the gland plate over the stem and on top of the packing.
6. Lubricate gland plate fastener threads with an anti-galling lubricant approved for oxygen service. e.g. Fluorolube.
7. Install a lock washer onto each of the gland plate fasteners and then install each of the fastener and lock washer assemblies into the gland plate and bonnet.
8. Install the follower over the stem until it rests on the top of the gland plate.
9. Install a spring washer onto the stem with the concave side facing upward (away from the bonnet).
10. Install a second spring washer onto the stem with the concave side facing downward.
11. Install the ground wire terminal on the stem.
12. Install the remaining spring washers onto the stem, ensuring that the direction of all spring washers alternate, and that no two adjacent springs are nested or are “parallel”.
13. Lubricate the stem threads with an anti-galling lubricant approved for oxygen service. e.g. Fluorolube.
14. Thread a jam nut onto the stem. Tighten the jam nut to completely compress the spring washers, then back off 1/4 turn.
15. Tighten the gland plate down, to compress the packing, to the torque shown in Table 3 for low emission valve stem packing only (ensuring the gland plate is level).
  - a. Note: For valves with oxygen cleaned stem packing, tighten the gland plate bolts only until the lock washers have been fully compressed.
16. **For Manual Valves Only:** Install the handle and lock components onto the stem such that the right side of the handle will contact the stop pin when the valve is in the open and closed positions. Install and tighten the remaining jam nut to secure the handle to the stem. This step does not apply to valves with gear operators
17. Install the bonnet gasket in the groove on the body, and then install the bonnet on the body.
18. Lubricate bonnet fastener threads with an anti-galling lubricant approved for oxygen service. e.g. Fluorolube.
19. Install a lock washer onto each of the bonnet fasteners and then install each of the fastener and lock washer assemblies into the bonnet. Tighten the bonnet fasteners as per Table 2 and the illustration on Page 4 of these instructions.
20. Rotate the stem to close the valve. Insert the small ground spring into the hole in the bottom of the stem.
21. Install the seat back gaskets into the end fitting and the body.
22. Install a seat into the body cavity.
23. Install the ball into the body by orienting the slot in the ball to engage the stem tang, being careful not to nick or scratch the ball. When the valve is in the closed position, the vent hole in the ball should face towards the upstream (high pressure) end of the body.
24. Rotate the stem until the ball is in the open position. Install the seat and end fitting gasket into the body.
25. For valves with mechanically connected end fittings, install end fittings against body.
26. Lubricate external threads of body bolting with an anti-galling lubricant approved for oxygen service. e.g. Fluorolube.
27. Install fasteners, nameplate, and lock washers into the end fittings and body.
28. Install and hand-tighten the fasteners, and then close the valve. Be sure to verify that the vent hole is positioned on the High Pressure side of the valve when the ball is in the closed position.
29. Torque the body fasteners in a staggered and incremental sequence as per Table 2 of these instructions. Cycle the valve to verify freedom of operation.
30. For valves with gear operators, reinstall the bracket, coupling, and gear operator.
31. **For Automated Valves Only:** Reinstall the automation assembly with the bracket and coupling. Then reconnect air and electrical power.
32. If practical, check the valve seats and seals for leaks.
33. If the valve has mechanically connected end fittings, reinstall the valve into the piping.

Table 1 - Replacement Kits and Parts						
Valve Size	Repair Kit (Oxygen Clean)	Repair Kit (Low-Emission)	Ball (316L S/S)	Stem (17-4PH S/S)	Stem Spring Washers	Follower
1/2" & 3/4"	CNTFC6N - G - - 1	CNTFC6N - Z - - 1	C6HLC502	CPF-D605N-	SPK-E510	ANK-E506
1"	CNTFD6N - G - - 1	CNTFD6N - Z - - 1	C6HLD502	CPF-D605N-	SPK-E510	ANK-E506
1-1/2"	CNTFE6N - G - - 1	CNTFE6N - Z - - 1	C6HLE502	CPF-E605N-	SPK-H510	SPK-H506
2"	CNTFG6N - G - - 1	CNTFG6N - Z - - 1	C6HLG502	CPF-G605N-	SPK-K510	SPK-K506
3"	CNTFH6N - G - - 1	CNTFH6N - Z - - 1	C6HLH502	CPF-H605N-	SPK-K510	SPK-K506
4"	CNTFK6N - G - - 1	CNTFK6N - Z - - 1	C6HLK502	CPF-K605N-	MPK-L110	SPK-L506
6"	CNTFL6N - G - - 1	CNTFL6N - Z - - 1	C6HLL502	CPF-L605N-	SPK-M510	SPK-M506

**Notes for Table above:**

- Standard repair kits include V-TEF™ seats, Graphite stem packings, spring energized VTFE seat back gaskets, and Graphite body gaskets.
- Replacement parts are one each per part number.

**Tightening Procedure for Bonnet and End Fittings:**

- Hand-tighten fasteners.
- Wrench-tighten each fastener in the sequence illustrated at right until the spring washers begin to compress.
- Continue tightening fasteners 1/4 turn in sequence until the recommended torque value in Table 2 is achieved.

Table 2 - Fastener Torque		
Valve Size	Fastener Torque 600# Body/ Bonnet	
	in – lbs.	N - m
3/4"	225 / 150	25.4 / 17
1"	225 / 150	25.4 / 17
1-1/2"	300 / 150	33.9 / 17
2"	480 / 150	54.2 / 17
3"	480 / 150	54.2 / 17
4"	1200 / 250	135.6 / 28.2
6"	1200 / 250	135.6 / 28.2

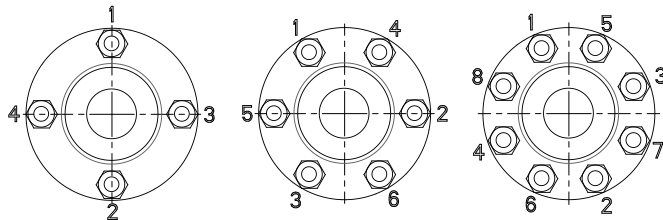

Table 3 – Gland Plate Fastener Torque (Low-Emission Stem Packing Only)		
Valve Size	In. - lbs.	N - m.
1/2" & 3/4"	25 - 35	2.8 - 4.0
1" & 1-1/2"	40 - 50	4.5 - 5.6
2" & 3"	100 - 125	11.3 - 14
4"	125 - 150	14 - 17
6"	125 - 150	14 - 17



1070 Sandy Hill Road, Irwin, PA 15642

Phone: (724) 863-0550 or (800) 967-4PBM Fax: (724) 864-9255

E-mail: info.pbmvalve@imi-critical.com Web: www.pbmvalve.com



© Copyright 2020 PBM, Inc. IOM-CN6-RP 600# R0 01/20 Printed in USA