

Technical Instructions for determining if a PBM Flush Tank valve has a cut-back weld pad



1. General

This Technical instruction is to provide reference information to help determine if an old Series 0 or Series 1 flush tank valve has a cut-back weld pad. Angle stem flush tank valve dimension is for standard valves. If this dimension is something different, please contact PBM.

2. Checking of dimensions per table below:

Verification of dimensions per the table below will help determine if a valve has a cut-back weld pad.

Valve Size	"A" Standard Valve	"A" Cut-Back Pad Valve	"B" Standard Valve	"B" Cut-Back Pad Valve	"C" Standard Valve	"C" Cut-Back Pad Valve	"D" Standard Valve	"D" Cut-Back Pad Valve	"E" Standard Valve	"E" Cut-Back Pad Valve	"F" Angle Stem Standard Valve
1"	1.41"	1.33"	.122"	.048"	.122"	.122"	.219"	.318"	.062"	.178"	1.49"
1-1/2"	2.22"	1.94"	.244"	.051"	.244"	.244"	.365"	.521"	.093"	.156"	2.33"
2"	2.58"	2.21"	.162"	.045"	.162"	.162"	.350"	.632"	.093"	.125"	2.73"
3"	3.72"	3.59"	.172"	.172"	.172"	.172"	.449" or 469"	.720"	.167" or 187"	.312"	3.94"
4"	4.31"	4.31"	.162"	.162"	.162"	.162"	.625"	.750"	.187"	.312"	4.69"

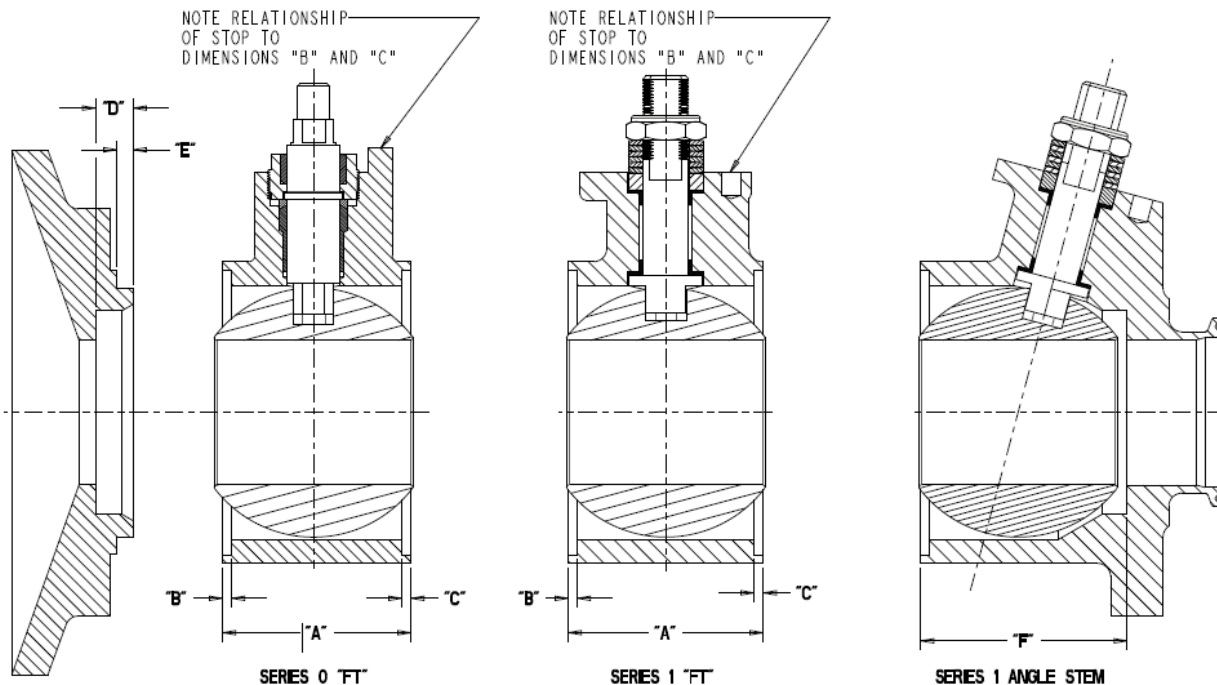

3. Type of Body Bolting

The type of body bolting also needs to be determined – please verify if the body bolts are either fine threads or coarse threads.



1070 Sandy Hill Road, Irwin, PA 15642

Phone: (724) 863-0550 or (800) 967-4PBM Fax: (724) 864-9255

E-mail: info.pbmvalve@imi-critical.com Web: www.pbmvalve.com



© Copyright 2020 PBM, Inc. IOM-CUTBACK-PAD R1 11/20 Printed in USA