

# Installation, Operation, and Maintenance Instructions HC and VC, 1/2" thru 4" Sanitary Check Valves



## **WARNING:**

For your safety and protection it is important that the following precautions be taken prior to working on the valve.

1. Depressurize and drain the line.
2. Determine the type of media in the process line and wear appropriate protective clothing and equipment. Obtain appropriate MSDS sheets.
3. To ensure safe product selection and operation, it is the responsibility of the process system designer and end user to determine the appropriate compatible materials of construction and adequate product ratings for the process system. Process system designer, installer, and end user are responsible for proper installation, operation, and maintenance.
4. When disposing of Teflon parts, do not incinerate or subject to open flames.

## 1. General

This Installation, Operation, and Maintenance manual is for the safe use of PBM 2-piece, HC and VC Sanitary Check Valves. Please read the instructions carefully and save them for future reference.

## 2. Installation

HC check valves must be installed in a horizontal direction and VC check valves must be installed in a vertical direction.

The body of the horizontal check valve (HC) is laser-etched with the word "TOP". In order to ensure proper drainage of the check valve, the check valve must be oriented such that "TOP" is facing vertically upward and at the highest point above the process line.

### **SAFETY NOTE:**

All valves which may see explosive media or see service in a potentially explosive area must be grounded to adjacent piping. The simplest way to achieve this with clamp ended valves is to mount the valve using metallic clamps.

## 3. Operation

Good operating procedure requires periodic inspection of the check valves and replacement of parts as required. Always use PBM factory authorized replacement parts.

Follow instructions to ensure optimum performance.

### Disassembly of check valve:

1. Loosen and remove the clamp, then pull the end fitting away from the body.
2. Remove the gasket and the poppet.

### Assembly of check valve:

1. Place the poppet in the body with the concave side of the poppet facing upward (see illustration).
2. Place the gasket into the groove of the body.
3. For VC vertical check valves, place the end fitting on the gasket, ensuring that it is seated properly on the gasket. In the case of the 1 inch check valve, be certain to orient the end fitting such that the concave side of the fitting is facing towards the poppet.
4. For HC horizontal check valves, place the end fitting on the gasket, ensuring that the laser-etched alignment markings on the body and end fitting are aligned, and that the end fitting is seated properly on the gasket (see illustration).
5. Install and tighten the clamp wing nut to 25 in-lbs. (2.9 N-m) of torque.

# HC Horizontal Check Valve

# VC Vertical Check Valve

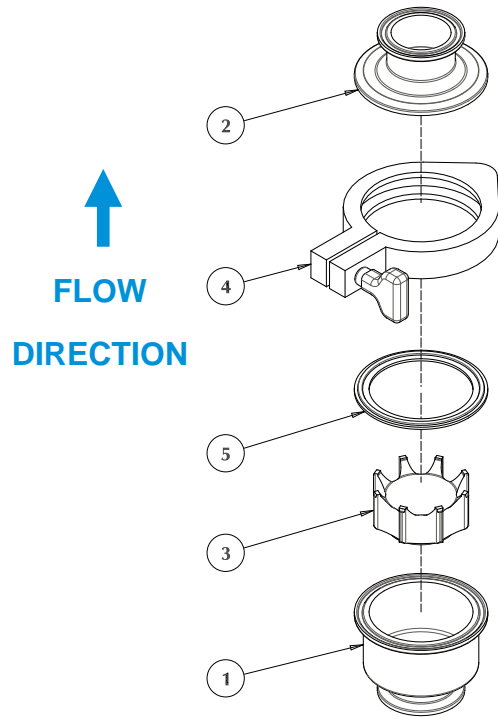
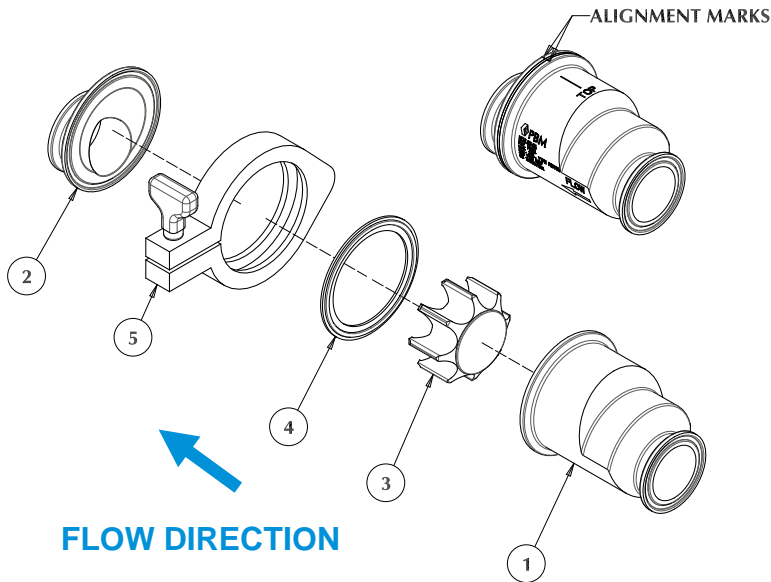

| HORIZONTAL PARTS LIST |             |
|-----------------------|-------------|
| ITEM                  | DESCRIPTION |
| 1                     | Body        |
| 2                     | End         |
| 3                     | Poppet      |
| 4                     | Gasket      |
| 5                     | Clamp       |

| VERTICAL PARTS LIST |             |
|---------------------|-------------|
| ITEM                | DESCRIPTION |
| 1                   | Body        |
| 2                   | End         |
| 3                   | Poppet      |
| 4                   | Clamp       |
| 5                   | Gasket      |

## Repair parts for VC and HC Check Valves

| Size       | Poppet   | Poppet Material | Gasket   | Gasket Material   |
|------------|----------|-----------------|----------|---|
| 1/2"       | HCVTC002 | Virgin PTFE     | HCXXC013 | Insert VI for FKM,<br>ED for EPDM,<br>Or VT for PTFE<br>in the gasket part<br>designation where<br>XX is shown. |
| 3/4"       | HCVTD002 |                 | HCXXD013 |   |
| 1"         | HCVTE002 |                 | HCXXE013 |   |
| 1-1/2"     | HCVTG002 |                 | HCXXG013 |   |
| 2"         | HCVTH002 |                 | HCXXH013 |   |
| 2-1/2", 3" | HCVTK002 |                 | HCXXK013 |   |
| 4"         | HCVTL002 |                 | HCXXL013 |   |



1070 Sandy Hill Road, Irwin, PA 15642

Phone: (724) 863-0550 or (800) 967-4PBM Fax: (724) 864-9255  
 E-mail: info.pbmvalve@imi-critical.com Web: www.pbmvalve.com  
 © Copyright 2020 PBM, Inc. IOM-CV R1 11/20 Printed in USA

