

Installation, Operation, and Maintenance Instructions 2-Way and Flush Tank Ball Valves SI, SP, FI, & FT Series 1, 1/2" thru 6", Series 4, 3" thru 6"



IMI PBM



WARNING:

For your safety and protection it is important that the following precautions be taken prior to working on the valve.

1. Depressurize and drain the line.
2. Cycle the valve to relieve any pressure trapped in the valve.
3. Disconnect any air and electrical connections to the valve assembly.
4. Know what the media is in the line and wear appropriate protective clothing and equipment. Obtain appropriate MSDS sheets.
5. To ensure safe product selection and operation, it is the responsibility of the process system designer and end user to determine the appropriate compatible materials of construction and adequate product ratings for the process system. Process system designer, installer, and end user are responsible for proper installation, operation, and maintenance.
6. Fasteners are designed to prevent loosening under normal operating conditions. Prior to commissioning at final point of operation, all valves should be inspected to ensure fasteners are tightened to manufacturer's recommendations and no damage has occurred during transit or handling.
7. When disposing of Teflon parts, do not incinerate or subject to open flames.

1. General

This Installation, Operation, and Maintenance manual is for the safe use of PBM 3-piece, Adjust-O-Seal[®], Bi-Directional, SI, SP, FI, and FT Series 1 ball valves. Please read instructions carefully and save for future reference.

2. Installation

Fasteners are designed to prevent loosening under normal operating conditions. Prior to commissioning at final point of operation, all valves should be inspected to ensure fasteners are tightened to manufacturer's Recommendations and no damage has occurred during transit or handling. SI, SP, FI, and FT valves may be installed in either direction with the valve in the "open" position. SI and SP valves do not need to be disassembled before installation except for socket weld, sil-braze, or solder joint end connections. For FI and FT valves, disassemble the valve and attach the tank pad to the vessel. Reassemble valve to tank pad. See IOM-WELD for welding of end connections or tank pads.

3. Operation

For manual valves, operation consists of turning the handle 1/4 turn to close or open the valve. When handle is parallel with the pipeline, the valve is in the open position. These valves may also be automated with actuators and other valve automation equipment. Mechanical handle stops must be removed if manual valves are converted to automated valves. For automated valves, operation is controlled by the actuator placed on top of the valve. Valve stops are an integral part of the actuators. Good operating procedure requires periodic inspection of the valves and replacement of parts as required. Always use PBM factory authorized replacement parts.

Follow instructions to ensure optimum performance:

Adjusting for Normal Wear

Note: Valve to be in fully opened or fully closed position prior to adjustments.

1. PBM Ball Valves are designed with the Adjust-O-Seal[®] feature. If the valve shows signs of leakage due to normal seat wear, tighten the end fitting fasteners evenly, in the staggered sequence as shown at bottom of Page 4, until the leakage stops and the valve operates smoothly:
 - a) Initially, there should be a space between end fittings and the body. This space is the key to the Adjust-O-Seal[®] feature and allows in-line adjustment of the seats and gasket.
 - b) End fitting fasteners should be tightened only until valve stem breakaway torque is reached (Torque Table - Page 4).
2. If valve shows signs of leakage in stem area due to normal stem packing wear, perform the following:
 - a) For valves 4" and smaller, tighten the locking jam nut on the stem to fully compress the spring washers, then back off the nut 1/8 turn. Leakage should fully stop, and the valve should continue to operate smoothly.
3. After adjustments have been made to seats, or if packing leakage cannot be stopped, a repair kit will be required.

PARTS LIST	
ITEM	DESCRIPTION
1	Stem Nut
2	Handle
3	Follower
3a	Follower (Manual Only)
4	Grounding (If Any)
5	Lock-Washers
6	Body Hex Nuts
7	Stop Disc (Manual Only)
8	Spring Washers
9	Stem Packings
10	Stem
11	Grounding Spring (If Any)
12	End Fittings
13	Body Bolts
14	Body Gaskets
15	Seats
16	Cavity Filler (If Any)
17	Ball
18	Body
19	Stop Pin (Manual Only)

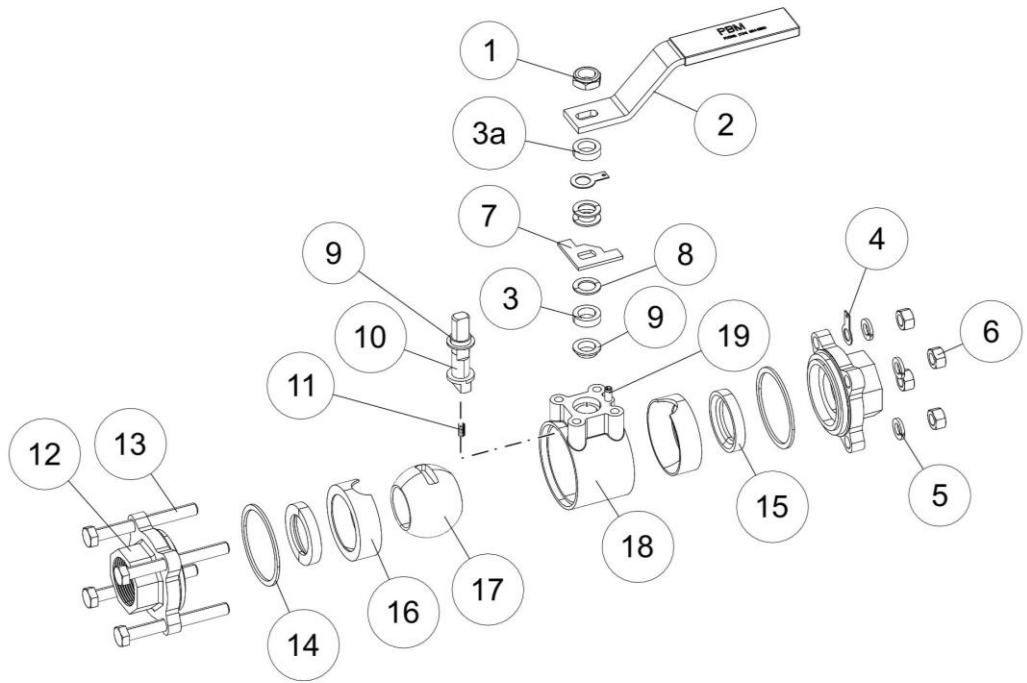

Disassembly of valve:

1. Isolate and depressurize the associated piping system. Cycle the valve to ensure there is no trapped pressure or fluid in the valve cavity. The valve should be left fully open or fully closed.
2. **For Automated Valves Only:** Remove all air and electrical power from the actuator, solenoid valve, and switchbox, if any. Then remove the automation assembly from the valve. Retain coupling and mounting bracket.
3. **For Manual Valves Only:** Loosen and remove the upper jam nut from the stem and then remove the handle.
4. Loosen and remove the hex nuts and lock washers from the fasteners. Remove the fasteners. Pull the end fitting(s) free from the body. Remove the body subassembly.
5. Remove the seat, gaskets, O-Rings, if any, and cavity fillers, if any.
6. Rotate the stem to orient the ball to the closed position. Slide the ball out, taking care not to nick or scratch the ball.
7. Remove the internal ground spring, if any, from under stem.
8. Remove the follower(s), any spring washers, stop disc, if any, and grounding, if any. For valves with gear operators, remove the gear operator, bracket, and coupling.
9. Push the stem into the body and out an open end of the body.
10. Remove the packings from the body and the stem.

Reassembly of valve:

1. Before reassembling the valve, examine the parts and repair or replace damaged or worn parts. Clean metal parts, as necessary, using a solvent compatible with the process fluid and a non-abrasive cloth. PBM recommends using new seats, body gaskets, and seals at each assembly.
2. Install a new bottom packing onto the threaded end of the stem and slide it down with the flanged surface touching the shoulder.
3. Insert the stem into body bore and through the stem bore in the body. Install the new top packing onto the stem with the flanged surface facing upwards. Push the packing into the body counterbore.
4. Install the follower onto the stem, until the follower is resting on the upper packing.
5. Lubricate the stem threads with an anti-galling lubricant.
6. For **Manual** 1" and smaller valves:
 - a) Install a spring washer, concave side facing upward, on the follower.
 - b) Install a second spring washer, concave side facing downward. Install a third spring washer, concave side facing upward. Ensure that the spring washers on the stem are in an alternating or *series* arrangement. No two adjacent spring washers should be facing the same direction or in a *parallel* arrangement.
 - c) Install the external ground wire, if any, between any two spring washers.
 - d) Install a second follower on top of the spring washers. Install the handle (with stops) on top of the follower such that the handle is over the stop pin when the valve is in the open position.
 - e) Thread the jam nut onto the stem and tighten to fully compress the spring washers, then back off the nut 1/8 turn.

7. For **Manual** 1-1/4" and larger valves:
 - a) Install a spring washer, concave side facing upward, on the follower. Install the stop disc such that the valve rotates 90° clockwise to open the valve.
 - b) Install two (three for 6" and 8" valves) more spring washers, alternating direction, starting concave side facing downward. If an external ground wire is used, install between any two spring washers. Ensure that the spring washers on the stem are in an alternating or *series* arrangement. No two adjacent spring washers should be facing the same direction or in a *parallel* arrangement.
 - c) Install a second follower on top of the spring washers. Install the handle on top of the follower such that the handle is over the stop pin when the valve is in the open position.
 - d) Thread the jam nut onto the stem and tighten to fully compress the spring washers, then back off the nut 1/8 turn.
8. For **Automated or Prepared for automation** valves:
 - a) For 1" and smaller valves, with a handle (03 option) and all valves that will be actuated (02 option), install a spring washer, concave side facing upward, on the follower.
 - b) For valves 1-1/2" and larger with a handle (03 option), install one spring washer, concave side facing upward, on the follower. Install the stop disc on top of the spring washer such that 90° clockwise stem rotation opens the valve.
 - c) Install a second spring washer onto the stem with the concave side facing downward. Install the remaining spring washers onto the stem in an alternating or *series* arrangement. No two adjacent spring washers should be facing the same direction or in a *parallel* arrangement.
 - d) For valves with a handle (03 option), install the handle on top of the spring washer such that the handle is over the stop pin when in the open position.
 - e) For 4" and smaller valves, tighten the locking jam nut on the stem to fully compress the spring washers, then back off the nut 1/8 turn.
 - f) For 6" and 8" valves, tighten the locking jam nut on the stem until the gap between the adjacent spring washers is about 0.1".
9. Rotate the stem to the closed position of the valve. Insert the internal ground spring, if any, into the hole at the bottom of the stem.
10. Orient the ball to the closed position and insert the ball into the body. Slide the stem tang into the ball slot, being careful not to nick or scratch the ball. Rotate the stem until the ball is in the open position.
11. Install the cavity fillers, if any, into the body.
12. Install the new seats, gaskets, and O-rings, if any, in their mating cavities in the end fittings. Lubricate O-rings with a lubricant compatible with the process fluid. Insert the end fittings in the body bores, making sure the seats, gaskets, and O-rings remain in position.
13. Lubricate external threads of body bolting with anti-galling lubricant.
14. Install fasteners, tagging, and lock washers then install and hand-tighten hex nuts. The external ground wire connected to the stem should have its terminal installed underneath one of the closest nuts and lock washers, if applicable. If the valve is electrically grounded, install the external ground spring around the bolt that passes through the swing out ring.
15. Wrench-tighten the bolting or hex nuts according to the procedure shown at the bottom of Page 4, while maintaining an even gap between the body and end fittings, and until the stem torque, as shown in the torque table on Page 4 is reached. The torque is the measured stem torque as the valve leaves the closed position. Cycle the valve to verify freedom of operation and torque. If practical, check the valve seats and seals for leaks.
16. For valves with gear operators, reinstall bracket, coupling, and gear operator.
17. **For Automated Valves Only:** Reinstall the automation assembly with the bracket and coupling. Then reconnect air and electrical power.
18. Insulate the valve, if applicable.

Tightening Procedure for End Fittings:

1. Hand tighten fasteners.
2. Wrench tighten each fastener in increments per the staggered sequence illustrated at right until the spring washers begin to compress.
3. Continue tightening bolts or hex nuts 1/8 turn until the recommended torque value is achieved when measuring at the valve stem.

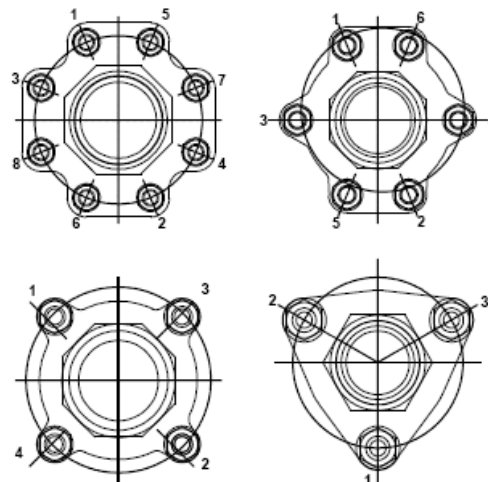

Replacement Kits and Parts					
Valve Size	SP, FT Repair Kit (RTFE)	SP, FT Cavity Filler Kit (VTFE)	SP, SI Ball (316L S/S)	Stem (316L S/S)	Spring Washers
1/2"	SPRTC1 -- A -- 1	SPVTC1 -- D -- 3	SPH-C102	SPHLC105	SPK-E110
3/4"	SPRTD1 -- A -- 1	SPVTD1 -- D -- 3	SPHLD102	SPHLC105	SPK-E110
1"	SPRTE1 -- A -- 1	SPVTE1 -- D -- 3	SPHLE102	SPHLE105	SPK-E110
1-1/4"	SPRTF1 -- A -- 1	SPVTF1 -- D -- 3	SPHLF102	SPHLF105	SPK-H110
1-1/2"	SPRTG1 -- A -- 1	SPVTG1 -- D -- 3	SPHLG102	SPHLH105	SPK-H110
2"	SPRTH1 -- A -- 1	SPVTH1 -- D -- 3	SPHLH102	SPHLH105	SPK-H110
2-1/2"	SPRTJ1 -- A -- 1	SPVTJ1 -- D -- 3	SPHLJ102	SPHLJ105	SPK-K110
3"	SPRTK1 -- A -- 1	SPVTK1 -- D -- 3	SPHLK102	SPHLK105	SPK-K110
4"	SPRTL1 -- A -- 1	SPVTL1 -- D -- 3	SPHLL102	SPHLK105	SPK-K110
6"	SPRTM1 -- A -- 1	SPVTM1 -- D -- 3	SPHLM102	SPHLM105	SPK-M110

Notes for Table above:

- For SI, FI repair kits, change SP repair kits to use VTFE – example SPVTC1—C—1.
- Standard repair kits include 2 RTFE seats, 2 RTFE body gaskets, and 2 RTFE stem packings.
- Cavity filler kits include 2 VTFE fillers.
- Standard repair kits and replacement parts are RTFE or VTFE.
- For 3" thru 6" Series 4 balls, change the 102 at the end to 402. For Series 4 repair kits, change the first 1 to a 4.
- Replacement parts are one each per part number.
- For materials other than RTFE, substitute the correct material ID and code.
- For valves with grounding, add "G" to the end of the stem part number.

Material Definitions:

TF	V-TEF™	Chemically modified polytetrafluoroethylene
HT	S-TEF®	Stainless steel reinforced polytetrafluoroethylene
RT	RTFE	Glass reinforced polytetrafluoroethylene
VT	VTFE	Virgin Polytetrafluoroethylene
PK	PEEK™	Polyetheretherketone
UT	UHMWPE	Ultra High Molecular Weight Polyethylene
KY	KYNAR	Polyvinylidene Fluoride

Notes for Table at right:

- Stem torques are shown in nominal values and represent ideal conditions. (100 psig / 6.9 bar or less, ambient temperature, with fluid free of suspended solids and comparable in viscosity to water).
- For UHMWPE seats, multiply by 1.25. For S-TEF® or Kynar seats, multiply by 1.56. Consult factory for PEEK seat torques.
- Torque values measured at the stem, NOT at the fasteners.

Valve Size	Size Code	Valve Stem Nominal Breakaway Torque – RTFE™ Seats	
		in – lbs.	N-m
1/2"	C1	48	5.4
3/4"	D1	60	6.8
1"	E1	72	8.1
1-1/4"	F1	132	14.9
1-1/2"	G1	168	19.0
2"	H1	192	21.7
2-1/2"	J1	300	33.9
3"	K1	420	47.5
4"	L1	540	61.0
6"	M1	1,920	216.9



1070 Sandy Hill Road, Irwin, PA 15642

Phone: (724) 863-0550 or (800) 967-4PBM Fax: (724) 864-9255
 E-mail: info.pbmvalve@imi-critical.com Web: www.pbmvalve.com
 © Copyright 2020 PBM, Inc. IOM-S1 R2 11/20 Printed in USA

