

Installation, Operation, and Maintenance Instructions 2-Way and Flush Tank Ball Valves SI, SP, FI, & FT Series 5, 1/2" thru 6", Non-Adjust-O-Seal



WARNING:

For your safety and protection it is important that the following precautions be taken prior to working on the valve.

1. Depressurize and drain the line.
2. Cycle the valve to relieve any pressure trapped in the valve.
3. Disconnect any air and electrical connections to the valve assembly.
4. Know what the media is in the line and wear appropriate protective clothing and equipment. Obtain appropriate MSDS sheets.
5. To ensure safe product selection and operation, it is the responsibility of the process system designer and end user to determine the appropriate compatible materials of construction and adequate product ratings for the process system. Process system designer, installer, and end user are responsible for proper installation, operation, and maintenance.
6. When disposing of Teflon parts, do not incinerate or subject to open flames.

1. General

This Installation, Operation, and Maintenance manual is for the safe use of PBM 3-piece, Non-Adjust-O-Seal®, Bi-Directional, SI, SP, FI, and FT Series 5 ball valves. Please read instructions carefully and save for future reference.

2. Installation

SI, SP, FI, and FT valves may be installed in either direction with the valve in the "open" position. SI and SP valves do not need to be disassembled before installation except for socket weld, sil-braze, or solder joint end connections. For FI and FT valves, disassemble the valve and attach the tank pad to the vessel. Reassemble valve to tank pad. See IOM-WELD for welding of end connections or tank pads.

3. Operation

For manual valves, operation consists of turning the handle 1/4 turn to close or open the valve. When handle is parallel with the pipeline, the valve is in the open position. These valves may also be automated with actuators and other valve automation equipment. Mechanical handle stops must be removed if manual valves are converted to automated valves. For automated valves, operation is controlled by the actuator placed on top of the valve. Valve stops are an integral part of the actuators. Good operating procedure requires periodic inspection of the valves and replacement of parts as required. Always use PBM factory authorized replacement parts.

Locking Handle Device, manual valves only – (When Supplied)

1. Depress handle lock bar inward toward the valve stem until it clears the stop on the valve body.
2. While maintaining the handle lock bar in this position, turn handle to desired position.
3. Release the handle lock bar, ensuring that it returns to the proper position against the handle.

Follow instructions to ensure optimum performance:

Adjusting for Normal Wear

1. If valve shows signs of leakage in stem area due to normal stem packing wear, loosen the upper jam nut on the stem, then tighten the lower jam nut as follows:
 - a) For valves 2" and smaller, tighten nut to completely compress spring washers, then loosen nut 1/2 turn.
 - b) For valves 3", tighten nut until a gap of about 0.05" (1.3 mm) exists between the adjacent spring washers.
 - c) For valves 4" and larger, tighten the nut until a gap of about 0.10" (2.5 mm) exists between the adjacent spring washers. Leakage should stop, and the valve should continue to operate smoothly.
2. If packing leakage cannot be stopped, a repair kit will be required.

| PARTS LIST | |
|------------|----------------------------------|
| ITEM | DESCRIPTION |
| 1 | Cavity Filler (If Any) |
| 2 | Stem Packings |
| 3 | Seat |
| 4 | Stop Pin |
| 5 | Stem Hex Nut(s) |
| 6 | Metal Shim Ring |
| 7 | Spring Washers |
| 8 | Follower |
| 9 | Handle (Manual Only) |
| 10 | Stem Packing |
| 11 | Stem |
| 12 | End Fitting |
| 13 | Body |
| 14 | Ball |
| 15 | Stem Ground Wire (If Any) |
| 16 | Lock Washer |
| 17 | End Fitting Hex Nut |
| 18 | Body Bolt |
| 19 | Body Bolt Ground Spring (If Any) |
| 20 | Stem Ground Spring (If Any) |

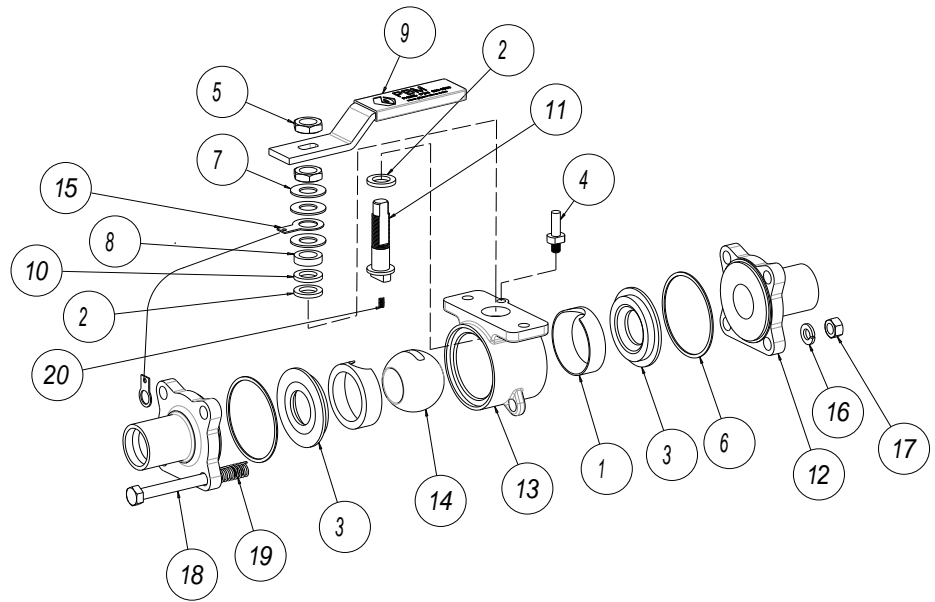

Disassembly of valve:

1. Isolate and depressurize the associated piping system. Cycle the valve to ensure there is no trapped pressure or fluid in the valve cavity. The valve should be left fully open or fully closed.
2. **For Automated Valves Only:** Remove all air and electrical power from the actuator, solenoid valve, and switchbox, if any. Then remove the automation assembly from the valve. Retain coupling and mounting bracket.
3. **For Manual Valves Only:** Loosen and remove the upper jam nut from the stem and then remove the handle.
4. For valves with welded end connections, the valve can be disassembled with the body subassembly swung out from the end fittings, or it can be disassembled with the body subassembly completely removed from the end fittings.
 - A. In order to swing out the body subassembly from the end fittings, fully open the valve and loosen the end fitting hex nuts. Then remove the fasteners, nuts, and lock washers between the body swing out ring and the stem.
 - B. Spring the connecting piping 1/8" to remove the compression on the body from the end fittings.
 - C. Swing the body out from the end fittings until the body completely clears the end fittings. The body's swing out ring will rotate about its fastener. The sprung piping can now be returned to its original compression, if desired.
 - D. In order to remove the body subassembly, loosen all end fitting fasteners. Then, remove the fasteners, including the nuts and lock washers, between the body swing out ring and the stem. Remove the fastener, including tag, nut, lock washers, and external ground spring, if any, that passes through the body swing out ring.
 - E. Spring the connecting piping 1/8" to remove the compression on the body from the end fittings.
 - F. Slide the body out from the end fittings until the body completely clears the end fittings. The sprung piping can now be returned to its original compression, if desired.
5. If the entire valve is to be removed from the piping, disconnect the end connections, remove the valve, then loosen and remove the body fasteners. Then pull the end fitting(s) free from the body. It may require force to remove.
6. Remove the seat, metal shim ring, and cavity filler, if any.
7. Rotate the stem to orient the ball to the closed position. Slide the ball out, taking care not to nick or scratch the ball.
8. Remove the internal ground spring, if any, from under stem.
9. Remove the jam nut, any spring washers, and follower. For valves with gear operators, remove the gear operator, bracket, and coupling.
10. Push the stem into the body and out an open end of the body. The bottom packing may come off with the stem. If not, reach into the body counterbore and remove.
11. Remove the top packings from the body, the inner cavity filler, if any, and the seat from the body recess.

Reassembly of valve:

1. Before reassembling the valve, examine the parts and repair or replace damaged or worn parts. Clean metal parts, as necessary, using a solvent compatible with the process fluid and a non-abrasive cloth. PBM recommends using new seats, body gaskets, and seals at each assembly.
2. Install a new packing onto the threaded end of the stem and slide it down until it contacts the shoulder.
3. Insert the stem into body bore and through the stem bore in the body. Install the remaining packings onto the stem with the S-TEF® (gray) packing installed last. Push the packings into the body counterbore. Install the follower onto the stem.
4. Install a spring washer onto the stem with the concave side facing upward. Install the external ground wire terminal onto the stem, if applicable, such that the ground wire extends towards the end fitting side of the body
5. Install a second spring washer onto the stem with the concave side facing downward. Install the remaining spring washers onto the stem in an alternating or *series* arrangement. No two adjacent spring washers should be facing the same direction or in a *parallel* arrangement
6. Lubricate the stem threads with an anti-galling lubricant.
7. Thread a stem hex nut onto the stem. For valves 2" and smaller, tighten the nut to completely compress the spring washers, then back off 1/2 turn. For 3" valves, tighten the nut until a gap of about 0.05" (1.3 mm) exists between the adjacent spring washers. For valves 4" and larger, tighten the nut until a gap of about 0.10" (2.5 mm) exists between the adjacent spring washers.
8. **For Manual Valves Only:** Install the handle on the stem such that stop pin will contact the right side of the handle when the valve is open and closed. Install and tighten the remaining hex nut to secure the handle to the stem. This step does not apply to valves with gear operators
9. Rotate the stem to the closed position of the valve. Insert the internal ground spring, if any, into the hole at the bottom of the stem.
10. Orient the ball to the closed position and insert the ball into the body. Slide the stem tang into the ball slot, being careful not to nick or scratch the ball. Rotate the stem until the ball is in the open position.
11. Install the cavity fillers, if any, into the body.
12. Install the seats into the body.
13. Install the metal shim ring onto the end fittings.
14. Lubricate external threads of body bolting with anti-galling lubricant.
15. For valves with end fittings welded into the piping, with the valve open, spring the end fittings outward and slide the body between them. Release spring force from the end fittings to allow the end fittings to enter the body.
16. For valves with the valve body in the swing-out position, spring the end fittings outward and slide the body between them. Release spring force from the end fittings to allow the end fittings to enter the body.
17. For valves that were completely removed, with the valve closed, install end fitting against body.
18. Install fasteners, tagging, and lock washers then install and hand-tighten hex nuts. The external ground wire connected to the stem should have its terminal installed underneath one of the closest nuts and lock washers, if applicable. If the valve is electrically grounded, install the external ground spring around the bolt that passes through the swing out ring.
19. Wrench-tighten the bolting or hex nuts according to the procedure shown at the bottom of Page 4 until the end fitting and metal shim ring comes into contact with the body, creating a tight seal.
20. For valves with gear operators, reinstall the bracket, coupling, and gear operator.
21. **For Automated Valves Only:** Reinstall the automation assembly with the bracket and coupling. Then reconnect air and electrical power.
22. Insulate the valve, if applicable.

Tightening Procedure for End Fittings:

1. Hand tighten fasteners.
2. Wrench-tighten each fastener in a staggered and incremental sequence as illustrated below until the recommended torque value in Table 2 on Page 4 is achieved.

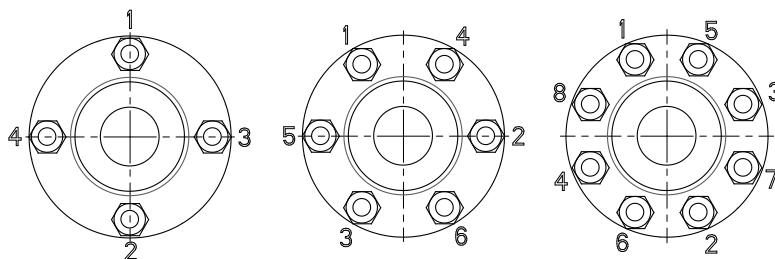

| Replacement Kits and Parts | | | | | | | |
|----------------------------|----------------------------|---------------------------------|--------------------|--------------------|-----------------|----------------|-----------------|
| Valve Size | SP, FT Repair Kit (V-TEF™) | SP, FT Cavity Filler Kit (VTFE) | SP Ball (316L S/S) | SI Ball (316L S/S) | Stem (316L S/S) | Spring Washers | Metal Shim Ring |
| 1/2" | SPTFC5 -- G -- 1 | SPTFC5 -- J -- 3 | SPHLC502 | SIHLC502 | SPHLD505 | SPK-E110 | SPK-C513NA |
| 3/4" | SPTFD5 -- G -- 1 | SPTFD5 -- J -- 3 | SPHLD502 | SIHLD502 | SPHLD505 | SPK-E110 | SPK-D513NA |
| 1" | SPTFE5 -- G -- 1 | SPTFE5 -- J -- 3 | SPHLE102 | SIHLE402 | SPHLE505 | SPK-E510 | SPK-E513NA |
| 1-1/2" | SPTFG5 -- G -- 1 | SPTFG5 -- J -- 3 | SPHLG102 | SIHLG402 | SPHLH505 | SPK-H510 | SPK-G513NA |
| 2" | SPTFH5 -- G -- 1 | SPTFH5 -- J -- 3 | SPHLH102 | SIHLH402 | SPHLH505 | SPK-H510 | SPK-H513NA |
| 2-1/2" | SPTFJ5 -- G -- 1 | SPTFJ5 -- J -- 3 | SPHLJ102 | SIHLJ402 | SPHLK505 | SPK-K510 | SPK-J513NA |
| 3" | SPTFK5 -- G -- 1 | SPTFK5 -- J -- 3 | SPHLK402 | SIHLK402 | SPHLK505 | SPK-K510 | SPK-K513NA |
| 4" | SPTFL5 -- G -- 1 | SPTFL5 -- J -- 3 | ANH-L102 | SIHLL502 | SPHLL505 | MPK-L110 | SPK-L513NA |
| 6" | SPTFM5 -- G -- 1 | SPTFM5 -- J -- 3 | SPHLM502 | SIHLM502 | SPHLM505 | SPK-M510 | SPK-M513NA |

Notes for Table above:

- For SI, FI repair kits, change SP repair kits to begin with SI – example SITFC5—G—1.
- Standard repair kits include 2 V-TEF™ seats, 2 V-TEF™ stem packings, and 1 S-TEF® (gray) stem packing. Cavity filler kits include 2 VTFE fillers.
- Standard repair kits and replacement parts are V-TEF™.
- Replacement parts are one each per part number.
- For materials other than V-TEF™, substitute the correct material ID and code.
- For valves with grounding, add "G" to the end of the stem part number.

| Table 2 – Fastener Torque | | | |
|---------------------------|-----------|------------------------------------|------|
| Valve Size | Size Code | Fastener Torque Body / End Fitting | |
| | | in - lbs | N-m |
| 1/2" | C5 | 30 | 3.4 |
| 3/4" | D5 | 30 | 3.4 |
| 1" | E5 | 60 | 6.8 |
| 1-1/2" | G5 | 120 | 13.6 |
| 2" | H5 | 180 | 20.3 |
| 2-1/2" | J5 | 240 | 27.1 |
| 3" | K5 | 360 | 40.7 |
| 4" | L5 | 480 | 54.2 |
| 6" | M5 | 720 | 81.3 |

Material Definitions:

| | | |
|----|--------|--|
| TF | V-TEF™ | Chemically modified polytetrafluoroethylene |
| VT | VTFE | Virgin Polytetrafluoroethylene |
| HT | S-TEF® | Stainless steel reinforced polytetrafluoroethylene |
| PK | PEEK™ | Polyetheretherketone |
| UT | UHMWPE | Ultra High Molecular Weight Polyethylene |
| KY | KYNAR | Polyvinylidene Fluoride |



1070 Sandy Hill Road, Irwin, PA 15642

Phone: (724) 863-0550 or (800) 967-4PBM Fax: (724) 864-9255

E-mail: info.pbmvalve@imi-critical.com Web: www.pbmvalve.com

© Copyright 2020 PBM, Inc. IOM-S5-NA R1 11/20 Printed in USA

