

IMI PBM IGENIX® DIVERTER STEAM VALVES

3-Way, Cast Series 9 or Forged Series 8, 1/2" - 6"



DESIGN FEATURES:

- Unique Adjust-O-Seal® feature allows in-line valve adjustment to compensate for normal wear on valve seats.
- **DC Series Divertor Steam valves have o-rings.**
- Integral side-entry or bottom entry common port. Seats shall provide both upstream and downstream bubble-tight seal and be adjustable for inline wear.
- A single Divertor valve can replace two or three 2-Way valves to reduce cost and space.
- Full-port diameters minimize pressure drops (1/2 - 6").
- True-Bore® (tube) for sanitary valves
- Stem assembly accommodates IMI PBM Direct Mount Actuation for accurate alignment and increased cycling life.
- A Divertor Port ball valve can be an economical alternative to a 3-Way Multi-port valve depending on the sealing requirements.
- Full port design
- Valves are rated to full vacuum.
- Specify IMI PBM flow pattern.
- Certified Material Test Report (CMTRS) are provided for wetted components.
- Surface finishes are achieved without the use of ADIs (Animal Derived Ingredients).

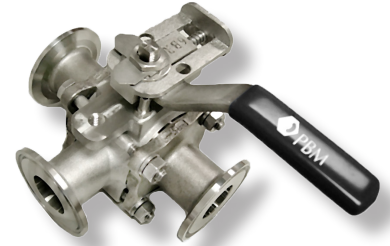

SPECIFICATIONS	SANITARY DIVERTER VALVES
Sizes	1/2" - 6"
Material	316L Stainless Steel with low controlled ferrite, Hastelloy® C276 or C22®, others
Temperatures	Ambient for V-TEF™ to 450° F depending on seat and seal material
End Connections	Extended tube, hygienic clamp, or others
Seats, Seals and Stem Packings	V-TEF™ or S-TEF® material
O-rings	EPR O-ring energizer (Viton V1274-75/80, EPR E3608-70, others available)
Body Bolts & Nuts	18-8 Stainless Steel
Maximum Working Pressure	up to 900 psig CWP depending on valve size and temperature
Polish	Standard internal polish of 20 Ra ID Series 8, 30 Ra ID Series 9

CV Values (gpm)			
Size	L-Port	T-Port	
		Straight	Branch
1/2"	4.0	4.7	3.0
3/4"	12	15	9.0
1"	25	29	18
1-1/2"	68	81	49
2"	133	160	92
3"	324	390	233
4"	590	715	430
6"	1,450	1,750	1,040

ID Surface Finish, Ra Readings for Valves per ASME BPE			
Surface Finish	IMI PBM Polish Code	μ-in.	μ-m.
Mechanical Polish			
SF 1	A	20 Ra max	0.51
SF 2	A	25 Ra max	0.64
SF 3	-	30 Ra max	0.76
Mechanical Polish and Electropolish			
SF 4	G	15 Ra max	0.38
SF 5	F	20 Ra max	0.51
SF 6	F	25 Ra max	0.64

How To Order:

PRODUCT (1-2) MATERIAL (3-4)		SIZE (5) SERIES (6)		END CONN. (7-8)		SEAT & SEAL (9)		FLOW PATTERNS (10-11)		BALL & STEM (12)		OPERATOR (13-14)		POLISH (15-16)			
DC	HL	Cast (Ser. 9) 316L S / S	C	1/2"	8	X-	Hygienic Clamp	G	V-TEF™ Seats / Seals FKM O-Rings	10	3-Way Side Entry L-Port Ball 90°	-	Standard Ball and Stem	--	W/ Standard Lever Handle (1/2" thru 4")	-	30 Ra ID (Std. Series 9)
	HF	Forged 316L S / S	D	3/4"	9	F-	Ext. Butt weld for Tube	J	V-TEF™ Seats / Seals / VTFE Cav Fill / FKM O-Rings	03	3-Way Side Entry T-Port Ball 90°	F	Internal / External Grounding	02	W/O Handle W/ Stem Actuator Prep	A	20 Ra ID (Std. Series 8)
		Other material options available - Contact PBM.		E	1"			Z	V-TEF™ Seats / Seals EPR O-Rings	04	3-Way Side Entry T-Port Ball 90°	G	17-4PH Stem	04	Locking Lever Handle (1/2" thru 4")	D	15 Ra ID
				G	1-1/2"			2	V-TEF™ Seats / Seals / VTFE Cav Fill / EPR O-Rings	14	3-Way Btm. Entry L-Port Ball 360°			08	Gear Operator (Req'd for 6")	E	10 Ra ID
				H	2"			0	S-TEF™ Seats / Seals FKM O-Rings	15	3-Way Btm. Entry L-Port Ball 180°			20	DA 80psig actuator	F	20 Ra ID after Electro Polish
				K	3"			H	S-TEF™ Seats / Seals FKM O-Rings	15	3-Way Side Entry L-Port Ball 180°			27	DA 60psig actuator	G	15 Ra ID after Electro Polish
				L	4"			0	S-TEF™ Seats / Seals EPR O-Rings	18	3-Way Btm. Entry LL-Port Ball 90°			34	SR 80psig actuator - Fail Position must be specified	H	10 Ra ID after Electro Polish
				M*	6"	* Not available in forged		9	V-TEF™ Seats / Seals FEP Encaps. FKM O-Rings	18	3-Way Btm. Entry LL-Port Ball 90°			41	SR 60psig actuator - Fail Position must be specified	H	10 Ra ID after Electro Polish

<http://pbmvalve.com/build-a-part-number>

Other Flow Pattern Options available - Contact PBM.
Other Seat/seal options available - contact PBM.

Other operator options available - Contact PBM.

More polish available - Contact PBM.

IMI PBM Igenix® Diverter Steam Valves

Diverter Port with Locking Handle

Diverter Port with Butt Weld Ends

Diverter Port with Gear Operator (6" only)

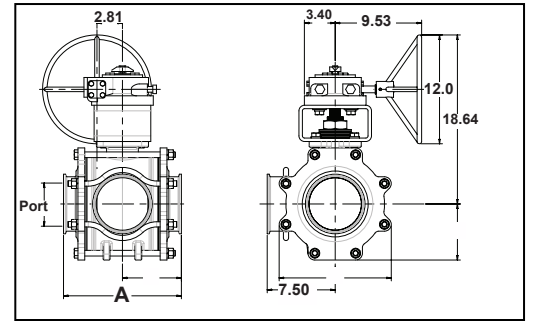
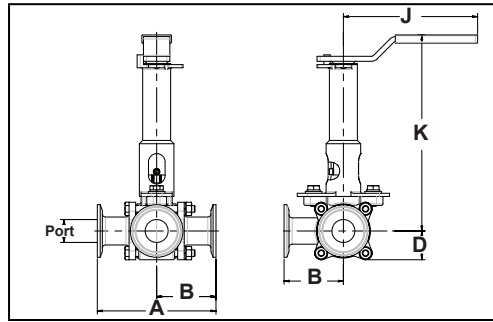
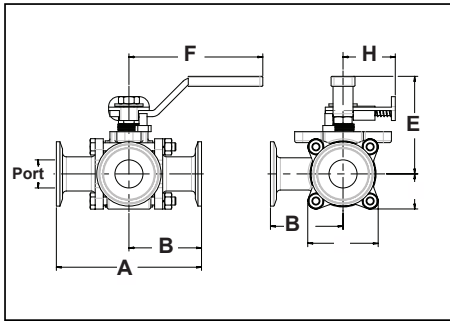

3-Way Diverter Steam valves dimensioned in inches												Locking Handle		Ext. Locking Handle		
Valve Size	Size Code	I.D. Port	A		B		D	E	F	G	Approx. Wgt (lbs)	H	Hole Dia. for Lock	J	K	Hole Dia. for Lock
			F-	X-	F-	X-										
1/2"	C	0.37	5.50	3.50	2.75	1.75	0.75	2.05	4.00	1.50	1.6	1.55	.28	5.09	4.00	0.31
3/4"	D	0.62	6.00	4.00	3.00	2.00	0.85	2.23	4.00	1.68	2.0	1.55	.28	5.09	4.14	0.31
1"	E	0.87	6.50	4.50	3.25	2.25	1.09	3.01	4.15	2.18	3.6	1.62	.25	5.09	5.44	0.31
1-1/2"	G	1.37	7.50	5.50	3.75	2.75	1.68	5.02	8.81	3.31	12.0	2.57	.38	8.00	7.46	0.38
2"	H	1.87	8.00	6.25	4.00	3.13	2.15	4.47	8.03	4.30	22.0	2.57	.38	8.00	7.74	0.38
3"	K	2.87	10.50	8.00	5.25	4.00	2.78	6.77	12.06	5.58	33.0	3.47	.38	12.06	11.61	0.44
4"	L	3.84	13.00	10.00	6.5	5.00	3.66	7.53	12.06	7.33	67.0	3.47	.38	12.06	12.38	0.44
6"	M	5.78	17.00	13.00	8.5	6.5	6.18	NA	NA	12.37	177.0**	NA	NA	NA	NA	NA

* Cast Only ** Weight without handle

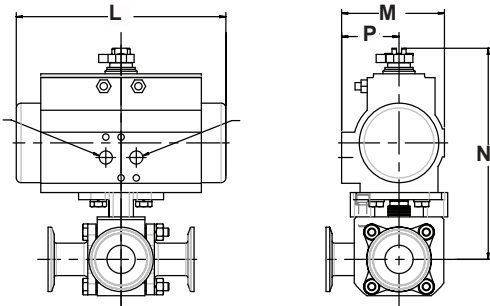

Code (#) Port Style	DIVERTER PORT • 3-way • SIDE ENTRY				DIVERTER PORT • 3-way • BOTTOM ENTRY				
	03 T-90°	04 T-90°	06 T-180°	10 L-90°	14 L-360°	15 L-180°	16 T-90°	17 TT-180°	18 LL-90°
Position A									
Position B									
Position C									
Position D									

ACTUATED DIMENSIONS

Unit of Measure = inches
Dimensions based on actuators used with V-TEF™ seats.

Size	80 PSI Spring Return					60 PSI Spring Return					60, 80 PSI Double Acting				
	L	M	N	P	R	L	M	N	P	R	L	M	N	P	R
1/2"	5.55	2.80	5.45	1.61	1/8 NPT	5.55	3.17	5.90	1.77	1/8 NPT	5.55	2.80	5.45	1.61	1/8 NPT
3/4"	5.55	2.80	5.59	1.61	1/8 NPT	6.46	3.17	6.04	1.77	1/8 NPT	5.55	2.80	5.59	1.61	1/8 NPT
1"	6.46	3.17	6.51	1.77	1/8 NPT	8.27	3.72	7.22	2.07	1/8 NPT	5.55	2.80	6.06	1.61	1/8 NPT
1-1/2"	9.47	4.17	9.65	2.30	1/8 NPT	10.83	4.84	9.65	2.68	1/4 NPT	8.27	3.72	9.10	2.07	1/8 NPT
2"	10.83	4.84	10.45	2.68	1/4 NPT	13.11	5.39	11.80	2.87	1/4 NPT	8.27	3.72	9.39	2.07	1/8 NPT
3"	14.65	5.83	14.21	3.15	1/4 NPT	17.13	6.46	15.10	3.44	1/4 NPT	13.11	5.39	13.73	2.87	1/4 NPT
4"	17.13	6.46	15.86	3.44	1/4 NPT	19.69	7.32	16.80	3.90	1/4 NPT	13.11	5.39	14.51	2.87	1/4 NPT
6"	22.78	8.54	23.02	4.29	1/4 NPT	22.64	11.42	27.78	5.71	1/4 NPT	22.78	8.54	23.02	4.29	1/4 NPT

Manual Valves with Tube Ends when used with insulation		
Tube OD	Insulation max with no extension	Insulation max with extension
0.50	0.76	2.68
0.75	0.79	2.72
1.00	1.45	3.88
1.50	3.10	5.57
2.00	2.31	5.60
3.00	4.08	8.88
4.00	4.35	9.12

www.PBMValve.com

PBM, Inc. • 1070 Sandy Hill Road, Irwin, PA 15642

Phone: 800.967.4PBM • 724.863.0550

E-mail: info.pbmvalve@imi-critical.com

