

IMI PBM IND. TANK BOTTOM STEAM VALVES

FD Series 5, 1/2" - 6"



DESIGN FEATURES:

- Unique Adjust-O-Seal[®] feature allows in-line valve adjustment to compensate for normal wear on valve seats. Note: **FD Series Tank Bottom Steam valves have o-rings.**
- Pad radius facilitates efficient drainage and reduces the pocket area above the ball.
- Upstream and downstream bubble-tight sealing capability allows valve body cleaning, purging, and draining.
- Stem assembly accommodates IMI PBM Direct Mount Actuation for accurate alignment and increased cycling life.
- Available in Angle Stem versions for applications where automation may interfere with tank head or jacket.
- Valves are rated for full vacuum.
- Standard bottom-entry stem provides protection from inadvertent stem removal. Engagement between the slot and ball is specially designed for high torque applications.



SPECIFICATIONS	2-Way Tank Bottom Valves
Sizes	1/2" - 6" depending on series
Material	316L, Hastelloy™, AL6XN, others
Temperatures	Ambient for V-TEF™ to 400° F, S-TEF [®] to 450° F
End Connections	Buttweld, Flange, NPT, Socket Weld, others
Seats & Seals	White V-TEF™ standard, others available
Stem Packing Material	V-TEF™ and S-TEF [®]
O-rings	EPR O-ring energizer (Viton V1274-75/80, EPR E3608-70, others available)
Body Bolts & Nuts	18-8 Stainless Steel
Maximum Working Pressure	up to 720 psig (49.6 bar) depending on valve series, size and temperatures
Temperatures	up to 450° F (232.2° C), depending on seat and seal material

CV Values (gpm), FD Series 5	
Size	End Connection
1/2"	14
3/4"	42
1"	70
1-1/2"	190
2"	370
3"	900
4"	1,650
6"	3,900

Custom pads for special applications

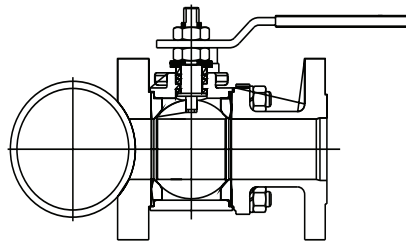

Cylindrical radius pads or reduced pocket cylindrical radius pads accommodate customer-specified or existing valve products.

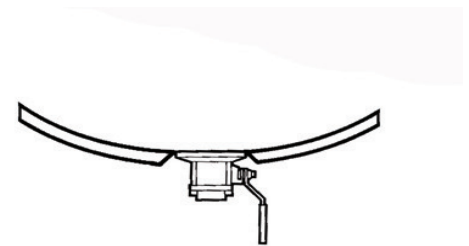

Spherical radius pads or reduced pocket spherical radius pads facilitate efficient drainage and reduces the pocket area above the ball.

How To Order:

PRODUCT (1-2) MATERIAL (3-4)		SIZE (5) SERIES (6)		END CONN. (7-8)	SEAT & SEAL (9)	Weld Pad (10-11)	BALL & STEM (12)	OPERATOR (13-14)	POLISH (15-16)						
FD	H- Cast 316/316L S / S	C	1/2"	5	B- Sch. 40 Butt Weld	G	V-TEF™ Seats / Seals FKM O-Rings	--	Standard Weld Pad	-	Standard Ball and Stem	--	W/ Standard Lever Handle	-	125 Ra ID Standard
	HL Cast 316L S / S	D	3/4"		D- Sch. 10 Butt Weld	J	V-TEF™ Seats / Seals / VTFE Cav Fill / FKM O-Rings	02	w/o weld pad w/ shipping pad	F	Internal / External Grounding	02	W/O Handle W/ Stem Actuator Prep	A	20 Ra ID
	C- Hastelloy C-276	E	1"		L- 150# Flange	Z	V-TEF™ Seats / Seals EPR O-Rings		Other Weld Pad Options available - Contact PBM.	G	17-4PH Stem	04	Locking Lever Handle	C	20 Ra ID / 32 Ra OD
	Y- Hastelloy C-22	H	2"		M- 300# Flange	2	V-TEF™ Seats / Seals / VTFE Cav Fill / EPR O-Rings			18	Extended Handle (1/2" thru 4")	F	20 Ra ID after Electro Polish		
	P- AL6XN	K	3"		Q- Female NPT		S-TEF [®] Seats / Seals FKM O-Rings		20	DA 80psig actuator					
	Other material options available - Contact PBM.	L	4"		U- Socket Weld		S-TEF [®] Seats / Seals FKM O-Rings		27	DA 60psig actuator					More polish available - Contact PBM.
		M	6"				S-TEF [®] Seats / Seals EPR O-Rings		34	SR 80psig actuator					
							V-TEF™ Seats / Seals FEP Encaps. FKM O-Rings		41	SR 60psig actuator					

IMI PBM Flush Tank Steam Valves Series 5 Manual

Flush Tank Valve with Locking Handle

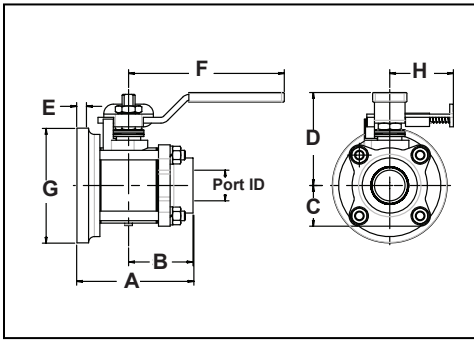

Flush Tank Valve with Ext. Locking Handle

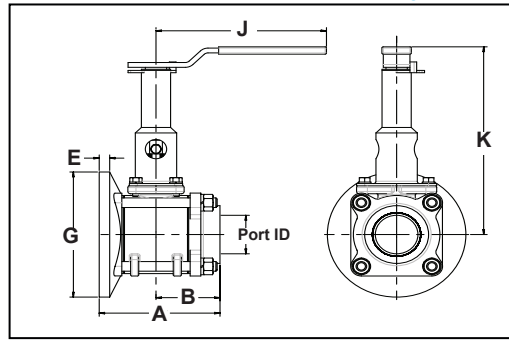

Flush Tank Valve with Gear Operator (6" only)

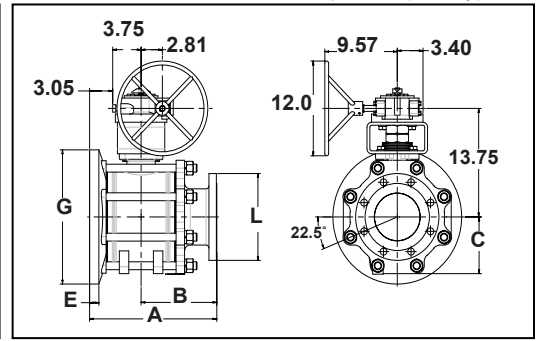

Industrial Flush Tank Dimensioned Valves in inches

Valve Size	Size Code	I.D. Port	A		B		Q _c to Bottom	Q _c to Top	Pad Thick.	Length from Q _c	Pad Dia.	End Fitting	Locking Handle		Ext Lock Handle		Approx Weight	
			Q-	L-	Q-	L-	C	D	E	F	G	L	Q-	Hole Dia.	J	K	Q-	L-
1/2"	C	0.5	2.83	4.02	1.56	2.75	0.98	2.63	0.28	4.15	2.75	3.50	2.75	.25	7.19	5.09	2 lbs.	3 lbs.
3/4"	D	0.75	3.07	4.23	1.72	2.88	1	2.78	0.31	4.15	3	3.88	3	.25	7.19	5.09	2.5 lbs.	4 lbs.
1"	E	1.0	3.84	4.96	2.13	3.25	1.33	3.1	0.32	5.09	3.75	4.25	3.75	.28	7.34	5.09	5 lbs.	7 lbs.
1-1/2"	G	1.5	5.07	6.32	2.75	4.00	1.78	4.41	0.46	8.68	5.5	5.00	5.5	.38	7.62	5.09	13 lbs.	16 lbs.
2"	H	2.0	5.66	7.54	3.00	4.88	2.2	4.7	0.49	8.68	6.5	6.00	6.5	.38	9.76	8.00	19 lbs.	25 lbs.
3"	K	3.0	8.38	10.26	4.50	6.38	3.1	6.78	0.77	12.44	9	7.50	9	.38	11.69	12.06	57 lbs.	68 lbs.
4"	L	4.0	10.81	12.31	6.00	7.50	4.9	7.34	0.9	24.44	11.5	9.00	11.5	.44	13.97	24.06	120 lbs.	133 lbs.
6"	M	6.0	NA	16.80	NA	10.00	7.2	Note 2	1.23	CF	17	11.00	17	NA	NA	NA	CF	CF

*Weight with gear operator.

ACTUATED DIMENSIONS

Unit of Measure = inches
Dimensions based on actuators used with V-TEF™ seats.

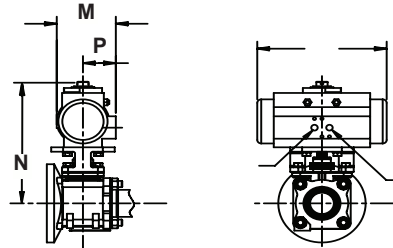

Size	80 PSI Double Acting					60 PSI Double Acting					80 PSI Spring Return					60 PSI Spring Return				
	L	M	N	P	R	L	M	N	P	R	L	M	N	P	R	L	M	N	P	R
1/2"	5.55	2.79	5.84	1.61	1/8	6.46	3.17	6.29	1.77	1/8	5.55	2.79	5.84	1.61	1/8	5.55	2.79	5.84	1.61	1/8
3/4"	6.46	3.17	6.44	1.77	1/8	6.46	3.17	6.44	1.77	1/8	5.55	2.79	5.99	1.61	1/8	5.55	2.79	5.99	1.61	1/8
1"	8.27	3.72	7.80	2.07	1/8	8.27	3.72	7.80	2.07	1/8	5.55	2.79	6.64	1.61	1/8	5.55	2.79	6.64	1.61	1/8
1-1/2"	10.83	4.85	10.16	2.68	1/4	10.83	4.85	10.16	2.68	1/4	6.46	3.17	8.39	1.77	1/8	8.27	3.72	9.10	2.07	1/8
2"	10.83	4.85	10.47	2.68	1/4	13.12	5.39	11.82	2.87	1/4	8.27	3.72	9.42	2.07	1/8	8.27	3.72	9.42	2.07	1/8
2-1/2"	13.12	5.39	13.48	2.87	1/4	14.65	5.83	13.96	3.15	1/4	13.12	5.39	13.48	2.87	1/4	13.12	5.39	13.48	2.87	1/4
3"	14.65	5.83	14.29	3.15	1/4	17.13	6.46	15.16	3.44	1/4	13.12	5.39	13.81	2.87	1/4	13.12	5.39	13.81	2.87	1/4



<http://www.pbmvalve.com/valves/tank-bottom-valve-0>

<http://pbmvalve.com/maintenance-instructions>

www.PBMValve.com

PBM, Inc. • 1070 Sandy Hill Road, Irwin, PA 15642

Phone: 800.967.4PBM • 724.863.0550

E-mail: info.pbmvalve@imi-critical.com

IMI Critical Engineering

