

IMI PBM FIRESAFE TANK BOTTOM VALVES

Tank Bottom Series 6, 1/2" - 3"



DESIGN FEATURES:

- Fire Rated, tested to API-607
- **FI Series Fire Rated Flush Tank valves have o-rings.**
- Three-piece "swing-out" body design
- Upstream and downstream bubble-tight sealing capability allows valve body cleaning and draining.
- True-Bore® design
- Valves are rated to full vacuum.
- Material Test Report (MTRS) provided for wetted components
- Surface finishes are achieved without the use of ADIs (Animal Derived Ingredients)
- Optional Fusible Link – A Spring Return Handle unit can be equipped with an optional fusible link specified to a customer's required melt temperature, which closes the valve during fire conditions.
- Direct mount automation

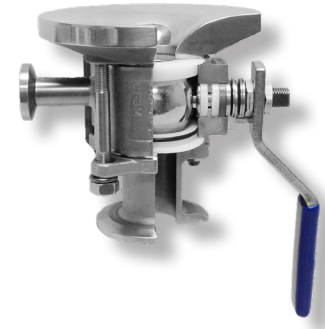

SPECIFICATIONS	2-Way Valves
Sizes	1/2" - 3"
Material	316/316L, (ASTM A351 CF3M), Hastelloy® C276 and other materials
Temperatures	Ambient for V-TEF™ to 400° F, S-TEF® to 450° F
End Connections	Extended tube, hygienic clamp, compression ends (1/2" - 1")
Seats & Seals	V-TEF™ or S-TEF® Seats, Graphite seals, O-rings (EPR, FKM standard)
Stem Packing Material	V-TEF™ or S-TEF®, Graphite secondary seals
Body Bolts & Nuts	18-8 Stainless Steel, Fully encapsulated
Maximum Working Pressure	up to 720 psig CWP depending on valve series, size and temperature
Temperatures	up to 450° F depending on seat and seal material
Polish	Standard internal polish of 30 Ra ID

CV Values (gpm), Series 6		
Size	End Connection	
	F-	X-
1/2"	7	8
3/4"	24	28
1"	55	60
1-1/2"	160	190
2"	370	420
3"	850	1,000

ID Surface Finish, Ra Readings for Valves per ASME BPE			
Surface Finish	IMI PBM Polish Code	µ-in.	µ-m.
Mechanical Polish			
SF 1	A	20 Ra max	0.51
SF 2	A	25 Ra max	0.64
SF 3	-	30 Ra max	0.76
Mechanical Polish and Electropolish			
SF 4	G	15 Ra max	0.38
SF 5	F	20 Ra max	0.51
SF 6	F	25 Ra max	0.64

How To Order:

PRODUCT (1-2) MATERIAL (3-4)		SIZE (5) SERIES (6)	END CONN. (7-8)		SEAT & SEAL (9)	PAD OPTIONS (10-11)	BALL & STEM (12)	OPERATOR (13-14)	POLISH (15-16)
FI	H- Cast 316/316L S / S	C 1/2"	6	F- Ext. Butt-weld for Tube	G V-TEF™ Seats / Graphite Seals / FKM O-Rings	-- Standard Weld Pad	- Standard Ball and Stem	-- W/ Standard Lever Handle	- 30 Ra ID Standard
	HL Cast 316L S / S	D 3/4"		X- Hygienic Clamp	J V-TEF™ Seats / Graphite Seals / VTFE Cav Fill / FKM O-Rings	02 w/o weld pad w/ shipping pad	G 17-4PH Stem	02 W/O Handle W/ Stem Actuator Prep	A 20 Ra ID
	C- Hastelloy C-276	E 1"		SM Compression (thru 1")	Z V-TEF™ Seats / Graphite Seals / EPR O-Rings	Other Weld Pad Options available - Contact PBM.		04 Locking Lever Handle	C 20 Ra ID / 32 Ra OD
		G 1-1/2"		G- Female Cherry Burrell				18 Extended Handle	
	Y- Hastelloy C-22	H 2"		H- Male Cherry Burrell	2 V-TEF™ Seats / Graphite Seals / VTFE Cav Fill / EPR O-Rings			20 DA 80psig actuator	F 20 Ra ID after Electro Polish
		K 3"						27 DA 60psig actuator	
	P- AL6XN				H S-TEF® Seats / Graphite Seals / FKM O-Rings			34 SR 80psig actuator	More polish available - Contact PBM.
					0 S-TEF® Seats / Graphite Seals / EPR O-Rings			41 SR 60psig actuator	
					9 V-TEF™ Seats / Seals / FEP Encaps. FKM O-Rings				

Other material options available - Contact PBM.

<http://pbmvalve.com/build-a-part-number>

Other Seat/seal options available - Contact PBM.

Other operator options available - Contact PBM.

IMI PBM Fire Rated FI Series 6, Manual

Flush Tank Valve with Locking Handle

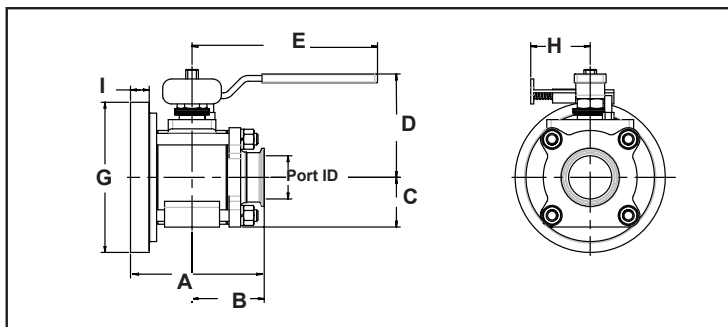

Flush Tank Valve with Extended Locking

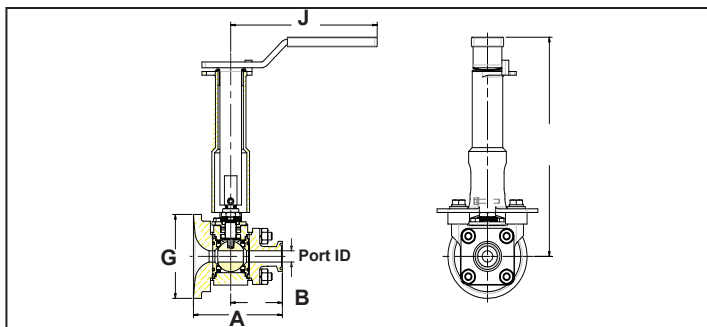

Flush Tank Firesafe Dimensioned valves in inches														Locking Handle		Ext. Locking Handle			
Valve Size	Size Code	ID Port	Face to Face		Q _c to Face		Q _c to Bottom	Q _c to Top	Length from Q _c	Butt Weld Length	Pad Dia. G	Pad < > I	Approx. Wgt. (lbs.)		H	Hole Dia. for Lock	J	K	Hole Dia. for Lock
			X-	F-	X-	F-	C	D					E	X-					
1/2"	C	0.37	3.09	4.04	1.80	2.75	.92	2.71	4.15	1.50	2.75	.28	2.70	2.70	1.62	.25	5.09	7.18	0.31
3/4"	D	0.62	3.36	4.11	2.00	2.75	1.00	2.73	4.15	1.50	3.00	.31	5.30	5.35	1.62	.25	5.09	7.33	0.31
1"	E	0.87	4.40	4.72	2.69	3.00	1.33	3.08	5.09	1.50	3.75	.32	6.40	6.26	1.62	.25	5.09	7.60	0.31
1-1/2"	G	1.37	5.09	6.09	2.75	3.75	1.78	4.38	8.03	1.50	5.50	.62	15.5	15.5	2.58	.38	8.00	9.44	0.38
2"	H	1.87	5.73	6.60	3.10	3.97	2.15	4.69	8.03	1.75	6.50	.81	22.5	22.5	2.58	.38	8.00	9.76	0.38

ACTUATED DIMENSIONS

Unit of Measure = inches
Dimensions based on actuators used with V-TEF™ seats.

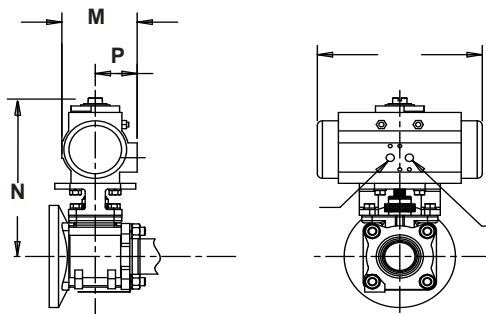

80 PSI Double Acting						60 PSI Double Acting					80 PSI Spring Return					60 PSI Spring Return				
Size	L	M	N	P	R	L	M	N	P	R	L	M	N	P	R	L	M	N	P	R
1/2"	5.55	2.79	5.84	1.61	1/8	6.46	3.17	6.29	1.77	1/8	5.55	2.79	5.84	1.61	1/8	5.55	2.79	5.84	1.61	1/8
3/4"	6.46	3.17	6.44	1.77	1/8	6.46	3.17	6.44	1.77	1/8	5.55	2.79	5.99	1.61	1/8	5.55	2.79	5.99	1.61	1/8
1"	8.27	3.72	7.80	2.07	1/8	8.27	3.72	7.80	2.07	1/8	5.55	2.79	6.64	1.61	1/8	5.55	2.79	6.64	1.61	1/8
1-1/2"	10.83	4.85	10.16	2.68	1/4	10.83	4.85	10.16	2.68	1/4	6.46	3.17	8.39	1.77	1/8	8.27	3.72	9.10	2.07	1/8
2"	10.83	4.85	10.47	2.68	1/4	13.12	5.39	11.82	2.87	1/4	8.27	3.72	9.42	2.07	1/8	8.27	3.72	9.42	2.07	1/8
2-1/2"	13.12	5.39	13.48	2.87	1/4	14.65	5.83	13.96	3.15	1/4	13.12	5.39	13.48	2.87	1/4	13.12	5.39	13.48	2.87	1/4
3"	14.65	5.83	14.29	3.15	1/4	17.13	6.46	15.16	3.44	1/4	13.12	5.39	13.81	2.87	1/4	13.12	5.39	13.81	2.87	1/4



<http://www.pbmvalve.com/valves/tank-bottom-valve>

<http://pbmvalve.com/maintenance-instructions>



www.PBMValve.com

PBM, Inc. • 1070 Sandy Hill Road, Irwin, PA 15642

Phone: 800.967.4PBM • 724.863.0550

E-mail: info.pbmvalve@imi-critical.com

