

IMI PBM IGENIX® PINCH VALVES

PV SERIES, 1/2" - 1"



DESIGN FEATURES:

- IMI PBM Pinch Valves shut off media flow by exerting a clamping force on your existing flexible braided hose and clear tubing.
- IMI PBM's unique design offers absolute shut-off of flexible and braided tubing sizes up to and including 1" / 25.4 mm ID, 1-3/8" / 34.9 mm OD
- Fits over existing tubing without the need for process breaks
- Has absolutely no contact with any process media, thus will never introduce contaminants.
- Can be fitted with limit switches and/or position sensors for your monitoring/flow control needs.
- Modular safety cover shields the pinch area when the valve is in service. It can be opened to load/unload the valve without the need for process breaks or complete removal from the valve body.
- Independent test reports available on flexible braided hose and clear tubing on request.



SPECIFICATIONS	PINCH VALVES
Sizes	1/2" - 1"
Material	316L Stainless Steel, wrought or cast material
Pinch valve plunger	300 Series stainless steel
Stem o-ring	Viton USP Class VI
Knob, Safety Cover, Retaining Nut	Acetal
Allowable Working Pressure	Actuator pressure as low as 60 psig, 4.1 barq with a variety of optional limit switches
Polish	OD surfaces of 50 Ra ID maximum, 32 Ra optional mechanical polish

Pinch Valve Applications

Automated Valves:

- **On/Off valves on automated UF and Chromatography skids**
- **Valves with positioners for flow and pressure control on automated UF and Chromatography skids**

Manual Valves:

- **Shut off valves on bag totes**
- **Manual flow control on bench top UF systems**

Safety Covers to be specified and ordered separately based on tubing OD

Body Size	Code	Safety Cover Sizing Chart	Safety Cover Part Number
1/2-inch For use with hose ID size "C" body	00	Blank Safety Cap	PVACC11100
	02	For .272" OD Hose	PAVCC11102
	03	For .355" OD Hose	PAVCC11103
	04	For .447" OD Hose	PAVCC11104
	05	For .500" OD Hose	PAVCC11105
	06	For .625" OD Hose	PAVCC11106
	07	For .75" OD Hose	PAVCC11107
	08	For .875" OD Hose	PAVCC11108
1-inch For use with hose ID size "E" body	10	For 1.000" OD Hose	PAVCE11110
	11	For 1.125" OD Hose	PAVCE11111
	12	For 1.250" OD Hose	PAVCE11112
	13	For 1.375" OD Hose	PAVCE11113

How To Order:

Product (1-2)	Body Material (3-4)	Size (5)	Series (6)	Pinch Valve Operation (7-8)	Polish (9) (Mech. unless noted)	Tube OD (10-11)
PV PINCH VALVE	HL 316L Stainless Stl.	C 1/16" to 1/2" Tubing	1 PV	MV Manual	- STD polish (50 Ra OD Max)	02 .272" OD
		E 5/8" to 1" Tubing		A- Automated S/S Spring Return Actuator (60-200 psig air/gas supply)	C 32Ra OD	03 .355" OD
				AO A- with Manual Override	L 32Ra OD / EP	04 .447" OD
				AS A- with Inductive Proximity Switch		05 .500" OD
						06 .625" OD
						07 .750" OD
						08 .875" OD
						10 1.000" OD
						11 1.125" OD
						12 1.250" OD
						13 1.375" OD

<http://pbmvalve.com/build-a-part-number>

IMI PBM IGENIX® PINCH VALVES

MANUAL PINCH VALVES

Unit	Tube ID	Dimension					Weight
		A	B	C	D	E	
inches	≤ ½"	5.32	6.32	1.75	1.38	.88	1.4
mm	≤ 12.7	135.1	160.5	44.5	35.1	22.4	.64
inches	> ½" ≤ 1"	6.32	7.83	2.25	1.63	1.38	4.0
mm	> 12.7 ≤ 25.4	160.5	199.0	57.2	41.4	35.1	1.8

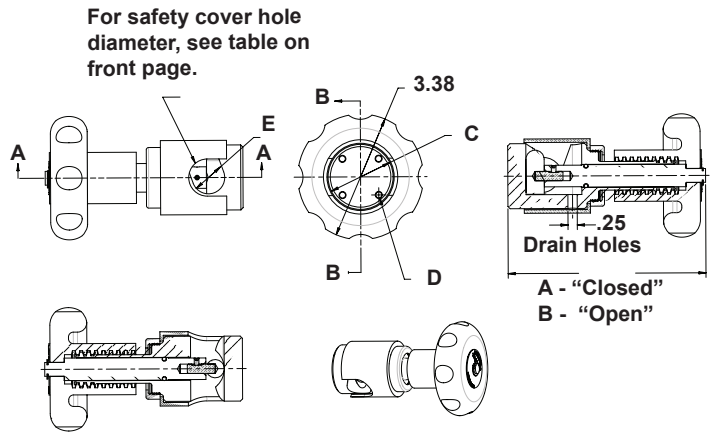

AUTOMATED PINCH VALVES

Unit	Tube ID	Dim.		Approx. Weight	
		A	C	lb.	kg.
in.	≤ ½"	11.80	1.75	7	3.2
mm	≤ 12.7	299.7	44.5		
in.	> ½" ≤ 1"	13.78	2.25	8.5	3.8
mm	> 12.7 ≤ 25.4	350.0	57.2		

