

IMI PBM INDUSTRIAL 2-WAY STEAM VALVE

SD Series 5, 1/4" - 6"



DESIGN FEATURES:

- Unique Adjust-O-Seal® feature allows in-line valve adjustment to compensate for normal wear on valve seats.
- **SD Series valves have o-rings.**
- Valve shall be a three-piece "swing-out" body design.
- Upstream and downstream bubble-tight sealing capability allows valve body cleaning, purging, and draining.
- Stem assembly accommodates IMI PBM Direct Mount Actuation for accurate alignment and increased cycling life.
- Full port design
- Valves are rated to full vacuum.
- Valves shall be a non-firesafe design unless otherwise specified.
- Solder Joint and Sil-brazed ends are bronze only.
- Socket weld ends for bronze valves must be 90/10 CuNi or 70/30 CuNi.

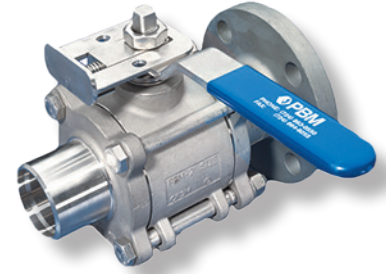

SPECIFICATIONS	2-Way Industrial Steam Valves
Sizes	1/4" - 6" Series 5
Material	316/316L, Hastelloy™ C-276, Carbon Steel, Bronze Alloy 922, 89833 Bronze or other
Temperatures	Ambient for V-TEF™ to 400° F, S-TEF® to 450° F, PEEK to 500° F
End Connections	Flange, NPT, Buttweld and Sil-braze for pipe, Socket weld for pipe, Solder Joint for tube
O-rings	EPR O-ring energizer (Viton V1274-75/80, EPR E3608-70, others available)
Seat, Seals & Stem Packings	V-TEF™ and S-TEF®
Body Bolts & Nuts	18-8 Stainless Steel
Maximum Working Pressure	up to 900 psig CWP depending on valve series, size and temperature

CV Values (gpm)	
Size	Series 5
1/4"	5*
3/8"	10*
1/2"	12
3/4"	42*
1"	73
1-1/2"	170
2"	360
2-1/2"	650
3"	935
4"	1,900
6"	4,800

End Fitting Length or Diameter			
Size	J-, U-	B-D-	L-
1/4", 3/8"	0.41	1.50	—
1/2"	0.41	1.50	3.50
3/4"	0.53	1.50	3.88
1"	0.53	1.50	4.25
1-1/2"	0.53	1.50	5.00
2"	0.66	1.75	6.00
2-1/2"	0.69	2.31	7.00
3"	0.69	2.31	7.50
4"	0.81	2.31	9.00
6"	NA	3.75	11.00

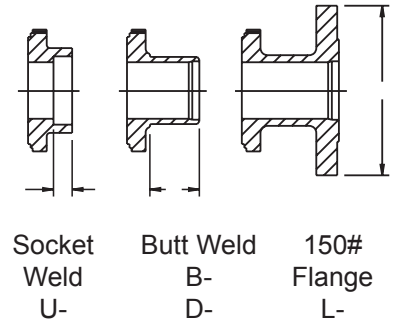

How To Order:

PRODUCT (1-2)		SIZE (5)		END CONN.		SEAT & SEAL		PURGES		BALL & STEM		OPERATOR		POLISH			
MATERIAL (3-4)		SERIES		(7-8)		(9)		(10-11)		STEM		(13-14)		(15-16)			
SD	H-	Cast 316/316L S/S	C	1/2"	5	B-	Sch. 40 Butt Weld	G	V-TEF™ Seats / Seals FKM O-Rings	--	No Purge Port or Ball Option	-	Standard Ball and Stem	--	W/ Standard Lever Handle	-	125 Ra ID Standard
	HL	Cast 316L S/S	D	3/4"		D-	Sch. 10 Butt Weld	J	V-TEF™ Seats / Seals / VTFE Cav Fill / FKM O-Rings	-8	Self Flushing Ball	F	Internal / External Grounding	02	W/O Handle W/ Stem Actuator Prep	A	20 Ra ID
	E-	Carbon Steel	E	1"		J-	Extended Socket Weld	Z	V-TEF™ Seats / Seals EPR O-Rings	-V	Slotted V-Ball	G	17-4PH Stem	04	Locking Lever Handle	C	20 Ra ID / 32 Ra OD
	C-	Hastelloy C-276	G	1-1/2"		L-	150# Flange*			-W	30° V-Ball			08	Gear Operator (Req'd for 6")	F	20 Ra ID after Electro Polish
		Hastelloy C-276	H	2"		M-	300# Flange*	2	V-TEF™ Seats / Seals / VTFE Cav Fill / EPR O-Rings	-X	45° V-Ball			18	Extended Handle (thru 4")		
	Y-	Hastelloy C-22	J	2-1/2"		P-	Male NPT			-Y	60° V-Ball			20	DA 80psig actuator		
		Hastelloy C-22	K	3"		Q-	Female NPT		S-TEF® Seats / Seals FKM O-Rings		Other Purge Port & Ball Options - Contact PBM.			27	DA 60psig actuator		More polish available - Contact PBM.
	P-	AL6XN	L	4"		S-	Sil Braze 1 Groove	H						34	SR 80psig actuator		
	N-	922 Bronze	M	6"		T-	Solder Joint	0	S-TEF® Seats / Seals EPR O-Rings					41	SR 60psig actuator		
	G-	89833 Bronze				U-	Socket Weld	9	TFM® Seats / Seals FEP Encaps. FKM O-Rings								

Other material options available - Contact PBM.

* Flat faced for Bronze
All others are raised face

Other Seat/seal options available-

Other operator options available - Contact PBM.

IMI PBM Industrial 2-Way Steam Valve, Manual

2-Way Valve with Locking Handle

2-Way Valve with Ext. Locking Handle

2-Way Valve with Gear Operator (6" only)

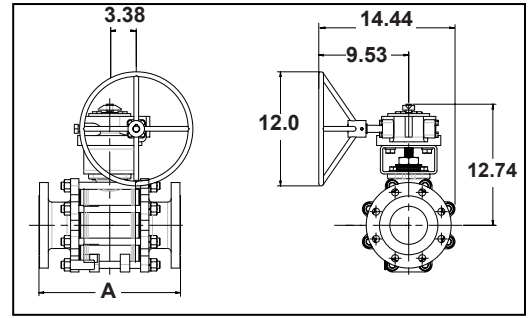
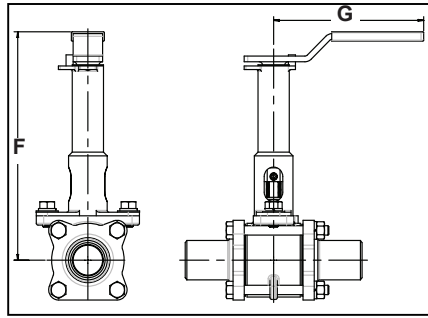
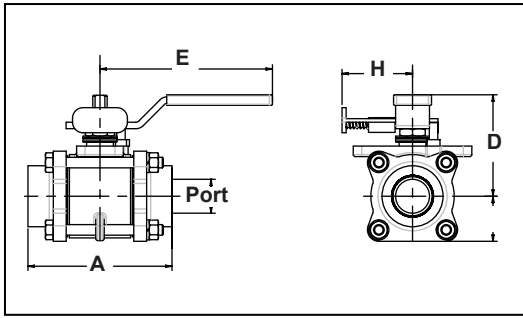

Valve Size	Size Code	Port Dia.	A				C Q to Bottom B- D- Q- S- T- U	D Q to Top of Handle	E Handle Length from Q	Ext. Locking Handle		Locking Handle		Approx. Weights	
			Face to Face							F	G	H	Hole Dia. for Lock	B- D- Q- U-	L-
			Q- U- S- T-	B- D-	J-	L-									
1/4", 3/8"	A,B	0.5	3.12	5.5	NA	NA	0.92	2.63	4.15	7.19	5.09	1.62	.25	1.7 lbs.	4.0 lbs.
1/2"	C	0.5	3.12	5.5	6.34	5.5	0.92	2.63	4.15	7.19	5.09	1.62	.25	1.7 lbs.	4.0 lbs.
3/4"	D	0.75	3.44	5.5	6.57	5.8	1	2.78	4.15	7.34	5.09	1.62	.25	2.0 lbs.	5.2 lbs.
1"	E	1	4.25	5.99	7.05	6.5	1.33	3.03	5.09	7.62	5.09	2.08	.28	4.5 lbs.	8.7 lbs.
1-1/2"	G	1.5	5.5	7.5	8.56	8	1.78	4.1	8.68	9.45	8.00	2.58	.38	10.2 lbs.	17.4 lbs.
2"	H	2	6	8	9.26	9.8	2.15	4.41	8.68	9.76	8.00	2.58	.38	15.4 lbs.	26.5 lbs.
2-1/2"	J	2.5	8	11.5	CF	11.5	2.79	6.45	12.44	11.36	12.06	3.47	.38	36.0 lbs.	53.5 lbs.
3"	K	3	9	13.5	14.88	12.8	3.14	6.78	12.44	11.69	12.06	3.47	.38	48 lbs.	68 lbs.
4"	L	4	12	16	CF	15	4.91	7.34	24.4	13.97	24.06	NA	.44	109 lbs.	157 lbs.
6"*	M	6	NA	22	CF	20	7.25	NA	NA	NA	NA	NA	NA	320 lbs.*	357 lbs.*

*Weight with gear operator.

ACTUATED DIMENSIONS

Unit of Measure = inches
Dimensions based on actuators used with V-TEF™ seats.

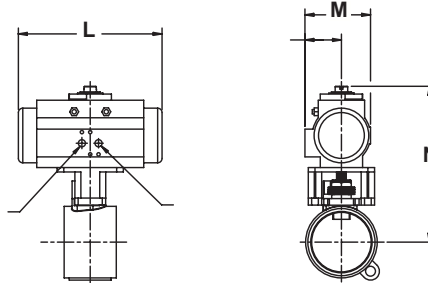

Size	80 PSI Double Acting					60 PSI Double Acting					80 PSI Spring Return					60 PSI Spring Return				
	L	M	N	P	R	L	M	N	P	R	L	M	N	P	R	L	M	N	P	R
1/2"	5.55	2.79	5.84	1.61	1/8	6.46	3.17	6.29	1.77	1/8	5.55	2.79	5.84	1.61	1/8	5.55	2.79	5.84	1.61	1/8
3/4"	6.46	3.17	6.44	1.77	1/8	6.46	3.17	6.44	1.77	1/8	5.55	2.79	5.99	1.61	1/8	5.55	2.79	5.99	1.61	1/8
1"	8.27	3.72	7.80	2.07	1/8	8.27	3.72	7.80	2.07	1/8	5.55	2.79	6.64	1.61	1/8	5.55	2.79	6.64	1.61	1/8
1-1/2"	10.83	4.85	10.16	2.68	1/4	10.83	4.85	10.16	2.68	1/4	6.46	3.17	8.39	1.77	1/8	8.27	3.72	9.10	2.07	1/8
2"	10.83	4.85	10.47	2.68	1/4	13.12	5.39	11.82	2.87	1/4	8.27	3.72	9.42	2.07	1/8	8.27	3.72	9.42	2.07	1/8
2-1/2"	13.12	5.39	13.48	2.87	1/4	14.65	5.83	13.96	3.15	1/4	13.12	5.39	13.48	2.87	1/4	13.12	5.39	13.48	2.87	1/4
3"	14.65	5.83	14.29	3.15	1/4	17.13	6.46	15.16	3.44	1/4	13.12	5.39	13.81	2.87	1/4	13.12	5.39	13.81	2.87	1/4



www.PBMValve.com

PBM, Inc. • 1070 Sandy Hill Road, Irwin, PA 15642

Phone: 800.967.4PBM • 724.863.0550

E-mail: info.pbmvalve@imi-critical.com

