

Industry: Chemical
Product: PBM Two Way Fire-rated Valve
Media: Hot Oil-based Liquid

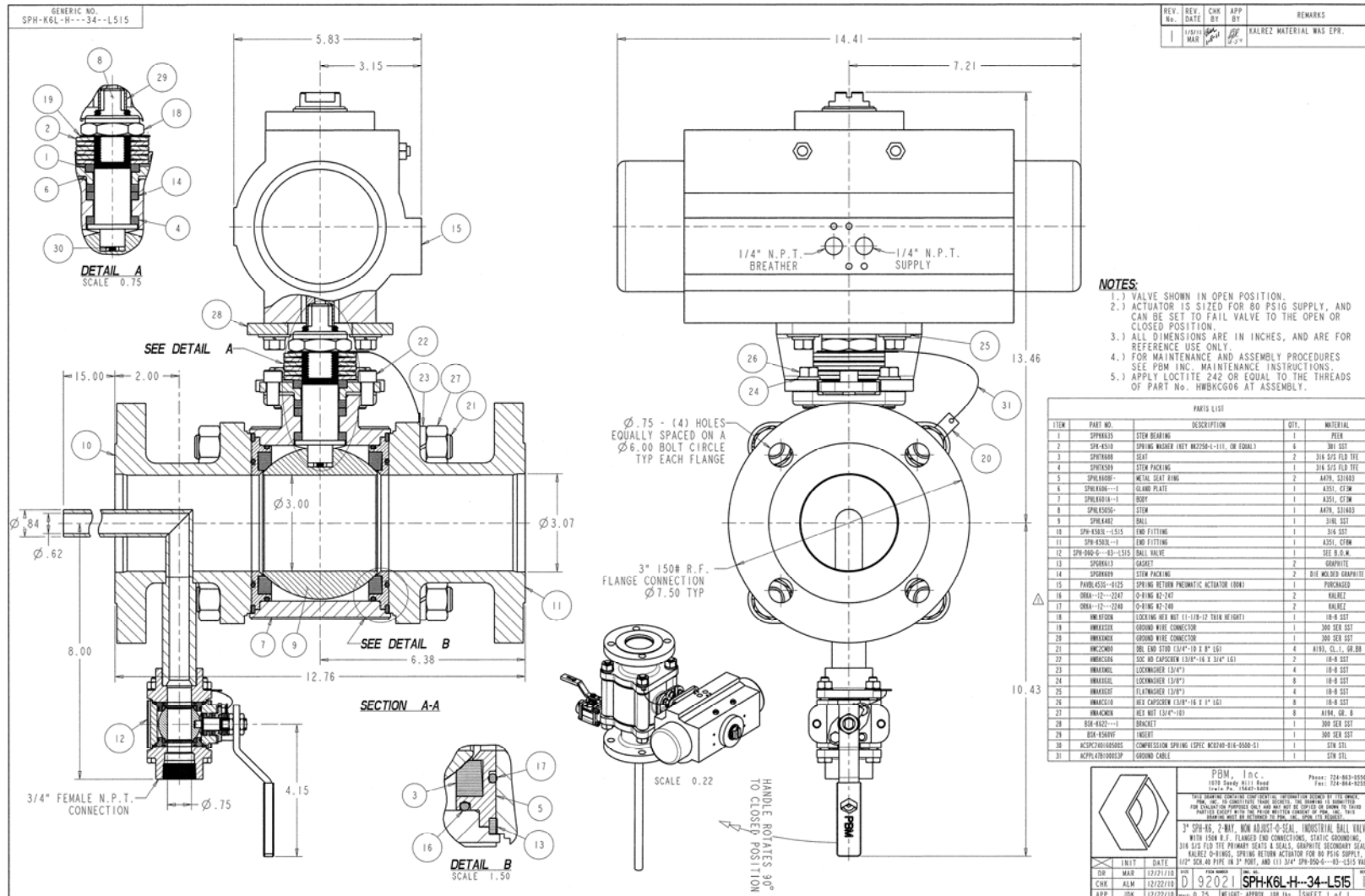

Application Brief: The jacket on an existing reactor made it impossible to use a flush-mounted tank bottom valve. PBM was asked to supply a valve with a nitrogen purge port to introduce a hot oil-based liquid into the reactor. The process, which occurs under vacuum, utilizes this unique PBM valve that eliminates leak paths and potential contamination while improving safety. This PBM valve replaced three 3" process valves and one 3/4" nitrogen valve on a "T" assembly, thus simplifying the process piping.

APPL 0111-60