

Industry: Petrochemical
Product: 3-inch full port Class 300 Double Block and Bleed valves
Application: Instrument and level bridle use - Coker
Media: Production of crude oil for conversion to different products

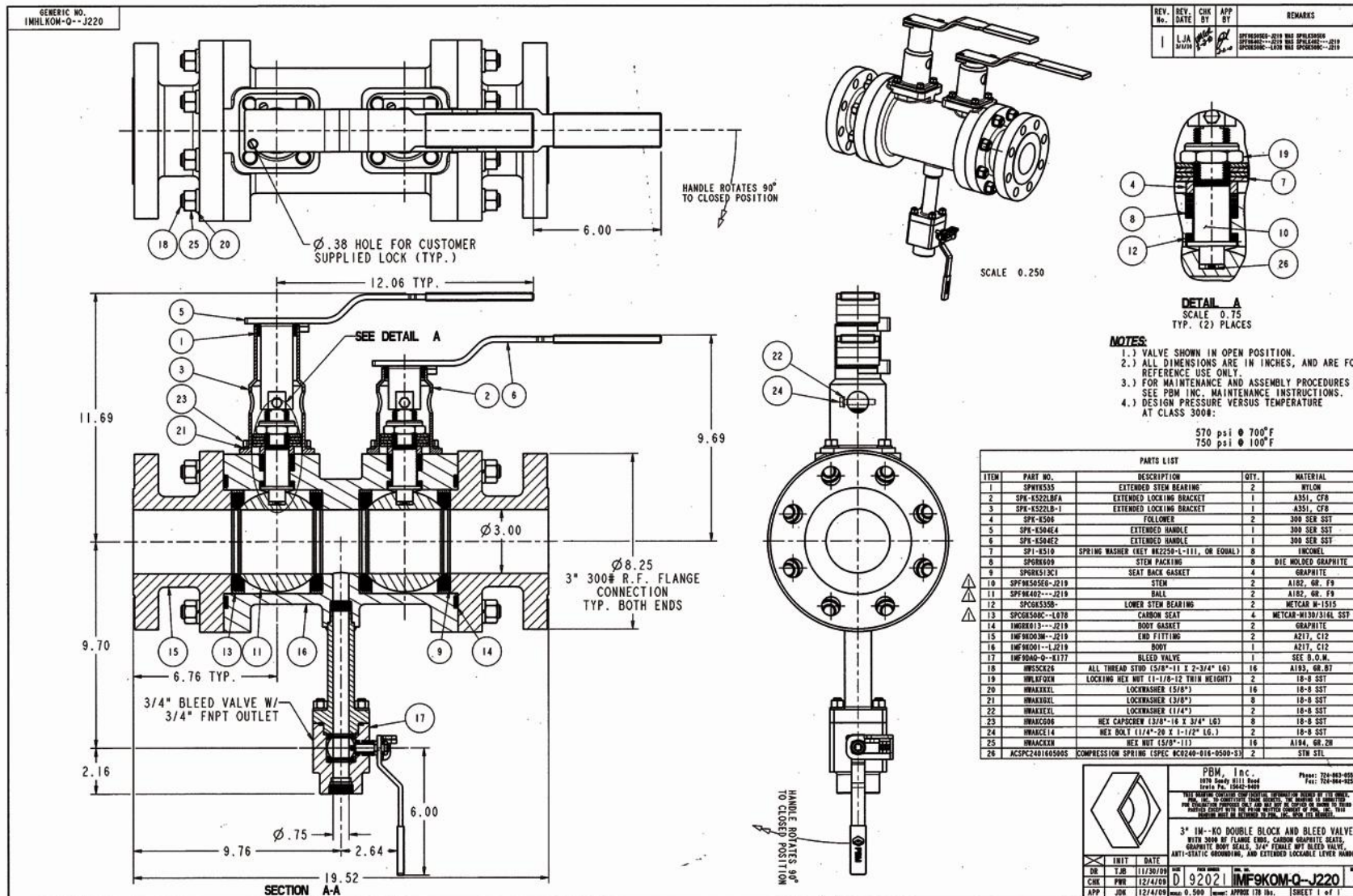

www.pbmvalve.com



Application Brief: A major engineering company needing valves for refinery coker lines chose PBM over the competitors because the valve bodies are one piece, there was less leak paths, a shorter face-to-face and less weight than the current design that was used in the past. This was critical because the valves were mounted on columns and weight was a concern. An additional savings on the length was a savings in space which brought the valves much closer to the vessel.

APPL 0510-45