

PBM FIRE RATED ANSI BALL VALVES

AN Series 6, 1/2" - 6"



DESIGN FEATURES:

- Fire Rated, tested to API-607
- Valves are rated for full vacuum.
- Valves are non-Adjust-O-Seal®.
- **AN Series Fire Rated ANSI valves have o-rings.**
- Valve are a two-piece "split body" design.
- Upstream and downstream bubble-tight sealing capability allows valve body cleaning, purging, and draining.
- Stem assembly accommodates PBM Direct Mount Actuation for accurate alignment and increased cycling life.
- Valves meet B16.34 in appropriate materials and ends.
- Optional Purge port and milled ball flats drain holes allow inline CIP to prevent clogging and plug formation.



SPECIFICATIONS	Industrial Fire Rated ANSI Valves
Sizes	1/2" - 6" Series 6
Material	316 Stainless Steel, Hastelloy® C-276, Carbon Steel, others
Temperatures	20°F to 450°F depending on seat and seal material
End Connections	150# & 300# RF Flange
Seats & Seals	White V-TEF™ standard, others available
O-rings	O-ring seal (FKM V1274-75/80, EPR E3608-70, others available)
Stem Packing Material	V-TEF™ and S-TEF®
Body Bolts & Nuts	B16.34 bolting
Maximum Working Pressure	up to 740 psig CWP depending on valve series, size and temperature

CV Values (gpm)			
Size	Cv (gpm)	Weight 150 # Class	Weight 300 # Class
1/2"	13	3.5 lbs.	4.8 lbs.
3/4"	52	6.8 lbs.	7.3 lbs.
1"	80	8 lbs.	11 lbs.
1-1/2"	190	16 lbs.	23 lbs.
2"	400	25 lbs.	30 lbs.
3"	1,100	50 lbs.	71 lbs.
4"	2,400	96	130
6"	5,600	242*	CF

*Valve approximate weight without handle

How To Order:

PRODUCT (1-2)		SIZE (5)		ENDS (7-8)		SEAT & SEAL (9)		Purge Ports (10-11)		BALL & STEM (12)		OPERATOR (13-14)		POLISH (15-16)			
MATERIAL (3-4)		SERIES (6)															
AN	H-	Cast 316/316 S/S	C	1/2"	6	L-	150# RF Flange	G	V-TEF™ Seats / Graphite Seals / FKM O-Ring	--	No Purge Port or Ball Option	-	Standard Ball and Stem	--	W/ Standard Lever Handle	-	125 Ra ID Standard
	E-	Carbon Steel	D	3/4"		M-	300# RF Flange	J	V-TEF™ Seats / Graphite Seals / VTFE Cav Fill / FKM O-Ring	- 8	Self Flushing Ball	G	17-4PH Stem	02	W/O Handle / W/ Stem Actuator Prep	A	20 Ra ID
	C-	Hastelloy C-276	E	1"				Z	V-TEF™ Seats / Graphite Seals / EPR O-Ring	- V	Slotted V-Ball			04	Locking Lever Handle	C	20 Ra ID / 32 Ra OD
	Y-	Hastelloy C-22	G	1-1/2"						- W	30° V-Ball			08	Gear Operator (Req'd for 6")		
			H	2"				2	V-TEF™ Seats / Graphite Seals / VTFE Cav Fill / EPR O-Ring	- X	45° V-Ball			18	Extended Handle (1/2" thru 4")	F	20 Ra ID after Electro Polish
	P-	AL6XN	K	3"						- Y	60° V-Ball			20	DA 80psig actuator		
		Other material options available - Contact PBM.	L	4"				H	S-TEF® Seats / Graphite Seals / FKM O-Ring	Other Purge Port & Ball Options - Contact PBM.				27	DA 60psig actuator		More polish available - Contact PBM.
			M	6"				0	S-TEF® Seats / Graphite Seals / EPR O-Ring					34	SR 80psig actuator		
								9	V-TEF™ Seats / Seals / FEP Encaps. FKM O-Rings					41	SR 60psig actuator		

Other operator options available - Contact PBM.

<http://pbmvalve.com/build-a-part-number>

PBM Fire Rated ANSI Ball Valves Manual

ANSI Valve with Locking Handle

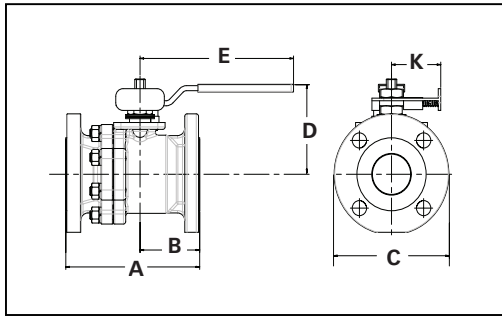

ANSI Valve with Ext. Locking Handle

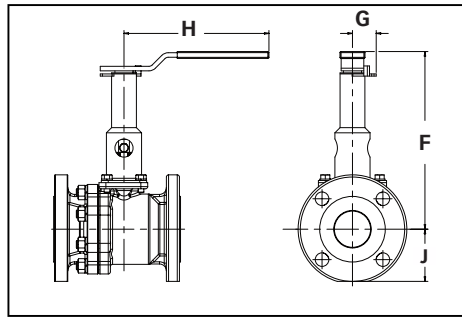

ANSI Valve with Gear Operator (6" only)

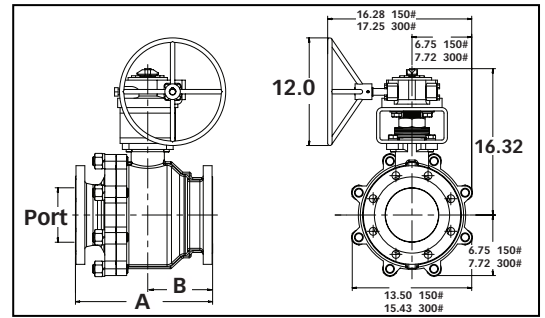

Valve Size	Size Code	Port Dia.	A		B		C		D	E	J		Ext. Locking Handle			Locking Handle			
			Overall Length		C _t to End		Flange Diameter				C _t to Top of Handle	Handle Length from C _t	C _t to Bottom		F	G	H	K	Hole Dia. for Lock
			150#	300#	150#	300#	150#	300#					150#	300#					
1/2"	C	0.5	4.25	5.50	1.85	2.52	3.50	3.75	2.66	4.15	1.62	1.75	7.19	1.00	5.09	1.62	.25		
3/4"	D	0.75	4.62	6.00	2.12	2.90	3.88	4.62	2.78	4.15	1.80	2.15	7.34	1.00	5.09	1.62	.25		
1"	E	1.00	5.00	6.50	2.25	3.15	4.25	4.88	3.09	5.06	2.06	2.38	7.63	1.00	5.09	2.08	.28		
1-1/2"	G	1.50	6.50	7.50	2.68	3.18	5.00	6.12	4.16	8.03	2.38	3.00	9.50	1.31	8.00	2.58	.38		
2"	H	2.00	7.00	8.50	3.12	3.84	6.00	6.50	4.46	8.03	2.88	3.12	9.81	1.31	8.00	2.58	.38		
3"	K	3.00	8.00	11.12	3.57	5.19	7.50	8.25	7.00	12.06	3.50	4.00	11.69	1.50	12.06	3.47	.38		
4"	L	4.00	9.00	12.00	3.84	5.34	9.00	10.00	7.39	24.06	4.38	4.75	13.03	3.50	24.06	NA	NA		
6"	M	6.07	15.50	15.88	7.33	7.70	11.00	12.50	NA	NA	NA	NA	NA	NA	NA	NA	NA		

ACTUATED DIMENSIONS

Unit of Measure = inches
Dimensions based on actuators used with V-TEF™ seats.

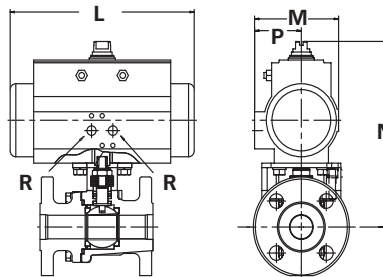

Size	80 PSI Double Acting					60 PSI Double Acting					80 PSI Spring Return C _t to Bottom					60 PSI Spring Return				
	L	M	N	P	R	L	M	N	P	R	L	M	N	P	R	L	M	N	P	R
1/2"	5.50	2.79	5.84	1.61	1/8	5.50	2.79	5.84	1.61	1/8	5.50	2.79	5.84	1.61	1/8	5.50	2.79	5.84	1.61	1/8
3/4"	6.38	3.17	6.44	1.77	1/8	6.38	3.17	6.44	1.77	1/8	6.38	3.17	6.44	1.77	1/8	6.38	3.17	6.44	1.77	1/8
1"	5.55	2.8	6.71	1.61	1/8	5.55	2.8	6.71	1.61	1/8	8.27	3.72	7.87	2.07	1/8	8.27	3.72	7.87	2.07	1/8
1-1/2"	6.46	3.17	8.44	1.77	1/8	8.27	3.72	9.15	2.07	1/8	10.83	4.84	10.2	2.68	1/4	10.83	4.84	10.2	2.68	1/4
2"	8.27	3.72	9.46	2.07	1/8	8.27	3.72	9.46	2.07	1/8	10.83	4.84	10.51	2.68	1/4	13.11	5.39	11.87	2.87	1/4
3"	13.11	5.39	13.81	2.87	1/4	13.11	5.39	13.81	2.87	1/4	14.65	5.83	14.29	3.15	1/4	17.13	6.46	15.18	3.44	1/4
4"	17.13	6.46	17.34	3.44	1/4	17.13	6.46	17.34	3.44	1/4	19.69	7.36	18.28	3.94	1/4	22.78	7.36	20.53	3.94	1/4
6"	22.78	8.58	24.11	4.29	1/4	22.78	8.58	24.11	4.29	1/4	22.78	8.58	24.11	4.29	1/4	26.46	11.42	28.87	5.71	1/4



<http://www.pbmvalve.com/valves/ansi-ball-valve>

<http://pbmvalve.com/maintenance-instructions>

www.PBMValve.com

PBM, Inc. • 1070 Sandy Hill Road, Irwin, PA 15642

Phone: 800.967.4PBM • 724.863.0550

E-mail: info@pbmvalve.com

