

PBM ANGLE STEM TANK BOTTOM VALVES

Fire Rated AF Series 3, 1" - 6"



DESIGN FEATURES:

- Fire Rated, tested to API-607
- **AF Series Fire Rated Tank Bottom valves have o-rings.**
- Designed for applications where automation may interfere with tank head or jacket.
- Pad radius facilitates efficient drainage and reduces the pocket area above the ball.
- Stem assembly accommodates PBM Direct Mount Actuation for accurate alignment and increased cycling life.
- Valves meet B16.34 in appropriate materials and ends
- Valves are rated for full vacuum.
- Certified Material Test Report (CMTRS) provided for weld pads and sanitary wetted components
- Surface finishes are achieved without the use of ADIs (Animal Derived Ingredients)

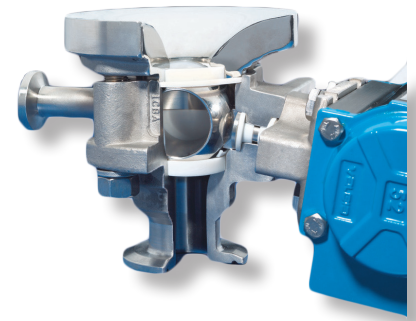

SPECIFICATIONS	Fire Rated Angle Stem Valves
Sizes	1" - 6" depending on series
Material	316L (ASTM A351 CF3M), Hastelloys and other ASME B16.34 listed materials
End Connections	Hygienic clamp, FNPT, 150# RF flange, others
Seats, Seals & Stem Packings	VTFE, RTFE, S-TEF® seats, graphite seals, o-rings (EPR, Viton standard)
Body Bolts & Nuts	18-8 Stainless Steel, body bolts are fully encapsulated
Maximum Working Pressure	up to 720 psig CWP depending on valve series, size and temperature
Temperatures	up to 450°F depending on seat and seal material
Polish	Standard internal polish of 125 Ra ID

CV Values (gpm), AF Series 3		
Size	End Connection	
	X-	Q, L
1"	63	65
1-1/2"	150	143
2"	280	280
3"	505	700
4"	690	880
6"	1,430	1,500

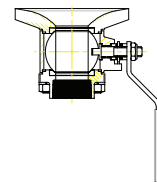
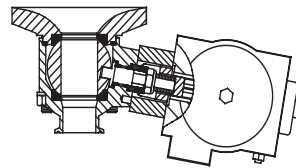

Straight Stem Flush Tank Ball Valve (FT)

Why an Angle Stem (AF) Flush Tank ball valve?

The PBM Angle Stem Flush Tank valve provides actuator clearance on jacketed or insulated vessels. On the 1" and the 1-1/2" AF valves, the stem is at a 10° offset from that of a straight stem Flush Tank (FT) ball valve and 15° for the 2", 3", 4" and 6" AF valves.

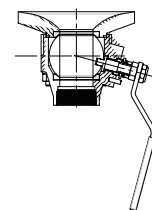

Angle Stem Flush Tank Ball Valve (AF)

How To Order:

PRODUCT (1-2)		SIZE (5)		END CONNECTION (7-8)		SEAT & SEAL (9)		WELD PAD (10-11)		BALL & STEM (12)		OPERATOR (13-14)		POLISH (15-16)			
AF	H-	Cast 316/316L S/S	E	1"	3	X-	Hygienic Clamp	A	RTFE Seats / Graphite Seals / FKM O-Ring	--	Standard Weld Pad	-	Standard Ball and Stem	--	W/ Standard Lever Handle	-	30 Ra ID
	HL	Cast 316L S/S	G	1-1/2"		Q-	FNPT	B	RTFE Seats / Graphite Seals / VTFE Cav Fill / FKM O-Ring	02	w/o weld pad w/ shipping pad	G	17-4PH Stem	02	W/O Handle W/ Stem Actuator Prep	A	20 Ra ID
	C-	Hastelloy C-276	H	2"		L-	150# RF Flange	C	VTFE Seats / Graphite Seals / FKM O-Ring	Other Weld Pad Options available - Contact PBM.				04	Locking Lever Handle	D	15 Ra ID
	Y-	Hastelloy C-22	K	3"		VTFE seats & seals Std for "X" RTFE seats & seals Std for "Q" & "L"		D	VTFE Seats / Graphite Seals / VTFE Cav Fill / FKM O-Ring					08	Gear Operator (Req'd for 6")	E	10 Ra ID
	P-	AL6XN	L	4"				H	S-TEF® Seats / Graphite Seals / FKM O-Ring					20	DA 80psig actuator	F	20 Ra ID after Electro Polish
			M*	6"				I	S-TEF® Seats / Graphite Seals / VTFE Cav Fill / FKM O-Ring					27	DA 60psig actuator		
														34	SR 80psig actuator	G	15 Ra ID after Electro Polish
														41	SR 60psig actuator		
														Other operator options available - Contact PBM.		H	10 Ra ID after Electro Polish

Other material options available - Contact PBM.

Other seat/seal options available - Contact PBM.

More polish available - Contact PBM.

<http://pbmvalve.com/build-a-part-number>

PBM Angle Stem Fire Rated Valve, Series 3, Manual

Angle Stem Flush Tank Valve, FNPT End

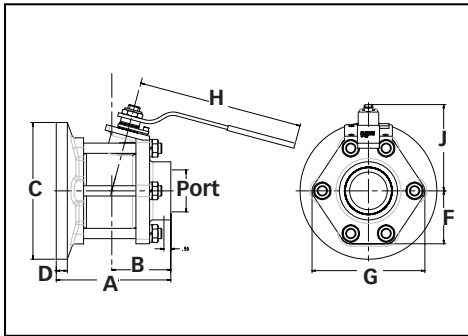

Angle Stem Flush Tank Valve, Flanged End

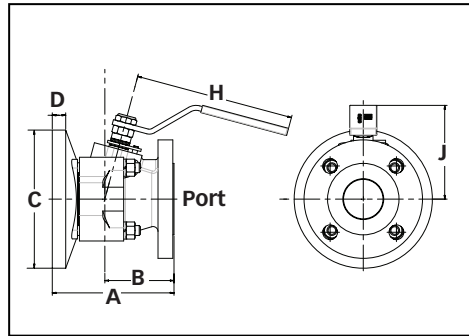

Angle Stem Flush Tank Valve with Gear Operator

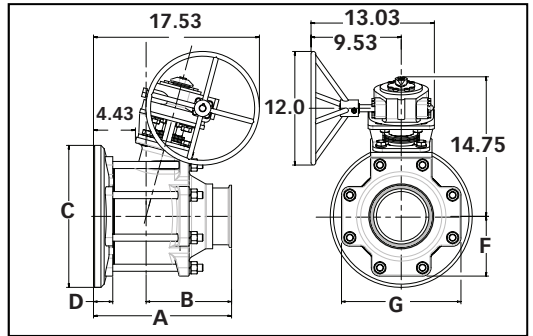

Angle Stem Tank Bottom Valve Dimensioned valves in inches

Valve Size	Size Code	I.D. Port	Face to Face A			C to End B			Pad Dia. C	Pad Width D	C to Bottom		Handle Length H	C to Top J	Approx. Wgt. (lbs.)		
			X	Q	L	X	Q	L			F	G			X	Q	L
1"	E	1.00	3.88	3.58	4.14	2.24	1.94	2.50	3.70	0.53	1.69	3.38	6.09	3.24	5.83	6.84	7.74
1-1/2"	G	1.50	4.71	4.97	5.53	2.43	2.69	3.25	5.50	0.62	1.78	3.44	8.06	4.90	12.25	12.88	16.26
2"	H	1.94	5.51	5.64	6.18	2.84	2.96	3.50	7.00	0.68	2.12	4.24	8.06	4.90	19.64	19.94	25.41
3"	K	2.75	7.88	8.38	9.19	3.81	4.31	5.12	10.00	0.79	3.87	8.25	12.06	6.79	62.60	63.50	74.81
4"	L	3.50	8.94	9.52	10.48	4.66	5.24	6.20	11.50	0.91	4.47	8.94	12.06	7.23	89.24	90.50	106.61
6"	M	5.24	14.59	NA	15.61	9.03	NA	10.05	15.00	1.04	6.31	12.62	NA	12.54	450.39	NA	474.11

* Weight without handle

ID Surface Finish, Ra Readings for Valves per ASME BPE			
Surface Finish	PBM Polish Code	μ-in.	μ-m.
Mechanical Polish			
SF 1	A	20 Ra max	0.51
SF 2	A	25 Ra max	0.64
SF 3	-	30 Ra max	0.76
Mechanical Polish and Electropolish			
SF 4	G	15 Ra max	0.38
SF 5	F	20 Ra max	0.51
SF 6	F	25 Ra max	0.64

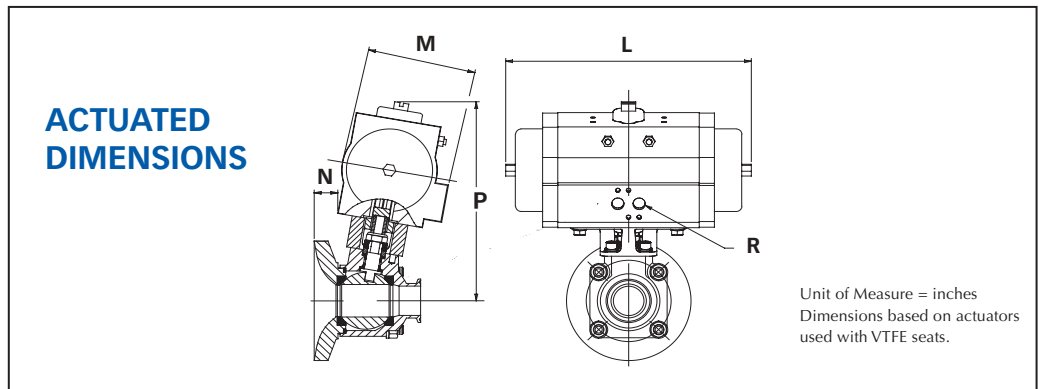

Size	80, 60 PSI Double Acting					80 PSI Spring Return					60 PSI Spring Return				
	L	M	N	P	R	L	M	N	P	R	L	M	N	P	R
1"	5.55	2.79	0.85	6.67	1/8 NPT	8.27	3.72	0.73	7.86	1/8 NPT	8.27	3.72	.73	7.86	1/8 NPT
1-1/2"	8.27	3.72	1.55	8.90	1/8 NPT	9.48	4.17	1.37	9.45	1/8 NPT	10.83	4.85	1.10	9.96	1/4 NPT
2"	8.27	3.72	2.49	8.97	1/8 NPT	10.83	4.85	2.07	10.01	1/4 NPT	13.12	5.39	1.86	11.32	1/4 NPT
3"	13.12	5.39	3.32	13.80	1/4 NPT	14.65	5.83	3.32	14.35	1/4 NPT	16.85	6.45	3.32	15.20	1/4 NPT
4"	13.12	5.39	3.66	14.41	1/4 NPT	16.85	6.45	3.66	15.58	1/4 NPT	16.85	6.45	3.66	15.58	1/4 NPT
6"	16.85	6.45	4.88	19.24	1/4 NPT	22.78	8.54	4.66	22.41	1/4 NPT	26.46	11.42	4.37	26.98	1/4 NPT



<http://www.pbmvalve.com/valves/tank-bottom-valve>

<http://pbmvalve.com/maintenance-instructions>

www.PBMValve.com

PBM, Inc. • 1070 Sandy Hill Road, Irwin, PA 15642

Phone: 800.967.4PBM • 724.863.0550

E-mail: info@pbmvalve.com

