

PBM INDUSTRIAL DIVERTER STEAM VALVES

3-Way DD Series 5, 1/2" - 4"



DESIGN FEATURES:

- Unique Adjust-O-Seal® feature allows in-line valve adjustment to compensate for normal wear on valve seats. Note: **DD Series valves have o-rings.**
- Integral side-entry or bottom entry common port. Seats shall provide both upstream and downstream bubble-tight seal and be adjustable for inline wear.
- A single Diverter valve can replace two or three 2-Way valves to reduce cost and space.
- Full-port diameters minimize pressure drops (1/2 - 4")
- Stem assembly accommodates PBM Direct Mount Actuation for accurate alignment and increased cycling life.
- A Diverter Port ball valve can be an economical alternative to a 3-Way Multi-port valve depending on the sealing requirements.
- Valves are rated to full vacuum.
- Specify PBM flow pattern
- Using a welded connection on the common port of a DP valve may complicate maintenance. Provisions must be made to allow removal of end fittings and body from the line. PBM recommends Female NPT (Q-) or flanged end fittings for common port connection for ease of valve maintenance.

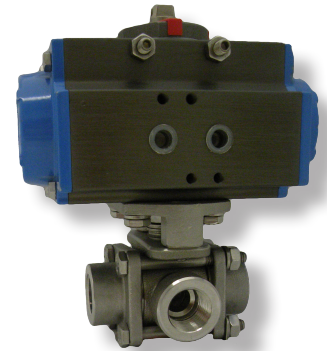

SPECIFICATIONS	DIVERTER VALVES
Sizes	1/2" - 4" Series 5
Material	316/316L, Hastelloy™ C-276, Carbon Steel, others available
Temperatures	Ambient for V-TEF™ to 400° F, S-TEF® to 450°F
End Connections	Flange, NPT, Socket weld
O-rings	EPR O-ring energizer (Viton V1274-75/80, EPR E3608-70, others available)
Seats, Seals and Stem Packings	V-TEF™ and S-TEF®
Body Bolts & Nuts	18-8 Stainless Steel
Maximum Working Pressure	up to 900 psig CWP depending on valve series, size and temperature

Cv Values (gpm)			
Size	L-Port	T-Port	
		Straight	Branch
1/2"	6.6	7.4	5.2
3/4"	17	20	13
1"	33	39	24
1-1/2"	79	93	58
2"	149	180	110
3"	350	415	250
4"	640	770	465

Socket Weld Depth or Flange Diameter		
Size	U-	L-
1/2"	0.41	3.50
3/4"	0.53	3.88
1"	0.53	4.25
1-1/2"	0.53	5.00
2"	0.66	6.00
3"	0.69	7.50
4"	0.81	9.00

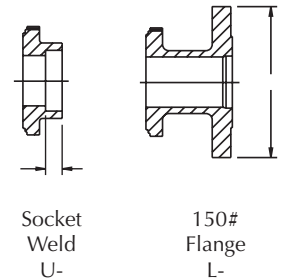

How To Order:

PRODUCT (1-2) MATERIAL (3-4)		SIZE (5) SERIES (6)		END CONN. (7-8)	SEAT & SEAL (9)	FLOW PATTERNS (10-11)	BALL & STEM (12)	OPERATOR (13-14)	POLISH (15-16)						
DD	H- Cast 316/316L S/S	C	1/2"	5	L- 150# Flange	G	V-TEF™ Seats / Seals FKM O-Rings	03	3-Way Side Entry T-Port Ball 90°	-	Standard Ball and Stem	--	W/ Standard Lever Handle	-	125 Ra ID Standard
	HL Cast 316L S/S	D	3/4"		Q- Female NPT	J	V-TEF™ Seats / Seals / VTFE Cav Fill / FKM O-Rings	04	3-Way Side Entry T-Port Ball 90°	F	Internal / External Grounding	02	W/O Handle W/ Stem Actuator Prep	A	20 Ra ID
	C- Hastelloy C-276	E	1"		U- Socket Weld	Z	V-TEF™ Seats / Seals EPR O-Ring	06	3-Way Side Entry T-Port Ball 180°	G	17-4PH Stem	04	Locking Lever Handle (1/2" thru 2") 08 Gear Operator (Req'd for 4")	C	20 Ra ID / 32 Ra OD
	Y- Hastelloy C-22	H	2"			2	V-TEF™ Seats / Seals / VTFE Cav Fill / EPR O-Rings	10	3-Way Side Entry L-Port Ball 90°			20	DA 80psig actuator	F	20 Ra ID after Electro Polish
	P- AL6XN	K	3"			H	S-TEF® Seats / Seals FKM O-Rings	15	3-Way Btm. Entry L-Port Ball 180°			27	DA 60psig actuator		
		L	4"			0	S-TEF® Seats / Seals EPR O-Rings	18	3-Way Btm. Entry LL-Port Ball 90°			34	SR 80psig actuator - Fail Position must be specified		
						9	V-TEF™ Seats / Seals FEP Encaps. FKM O-Rings		Other Flow Pattern Options available - Contact PBM.			41	SR 60psig actuator - Fail Position must be specified		

Other material options available - Contact PBM.

Other operator options available - Contact PBM.

Other Seat/seal options available - Contact PBM.

More polish available - Contact PBM.

<http://pbmvalve.com/build-a-part-number>

PBM Industrial Diverter Port Steam Valves Series 5

Diverter Port with Locking Handle

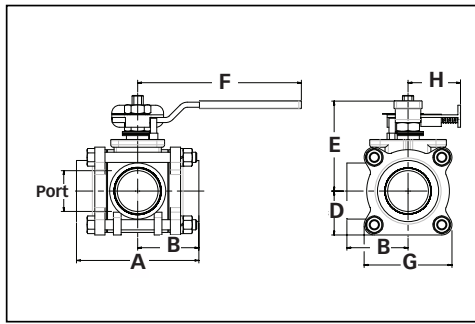

Diverter Port with Butt-weld Ends

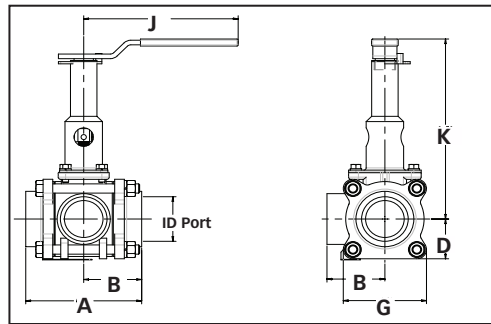

3-Way Diverter Port Dimensioned valves in inches													Locking Handle		Ext. Locking Handle		
Valve Size	Size Code	Port Dia.	A		B		D	E	F	G	Approx. Weight (lbs.)		H	Hole Dia. for Lock	J	K	Hole Dia. for Lock
			Q-, U-	L-	Q-, U-	L-					Q-, U-	L-					
1/2"	C	0.50	3.12	5.50	1.56	2.75	.92	2.63	4.15	1.84	2	5.2	1.55	.28	5.09	7.18	0.31
3/4"	D	0.75	3.44	5.75	1.72	2.88	1.0	2.78	4.15	2.00	2.5	7	1.55	.28	5.09	7.34	0.31
1"	E	1.00	4.25	6.50	2.13	3.25	1.33	3.03	5.09	2.66	5.0	11	1.62	.25	5.09	7.62	0.31
1-1/2"	G	1.50	5.50	8.00	2.75	4.00	1.78	4.10	8.68	3.56	11.5	21.5	2.57	.38	8.00	9.45	0.38
2"	H	2.00	6.00	9.75	3.00	4.88	2.15	4.41	8.68	4.38	16.5	33	2.57	.38	8.00	9.76	0.38
3"	K	3.00	9.00	12.75	4.50	6.38	3.14	6.78	12.44	6.28	50.0	80.0	3.47	.38	12.06	11.69	0.44
4"	L	4.00	12.00	15.00	6.00	7.50	4.91	7.34	24.40	9.82	123	155	3.47	.38	24.06	13.97	0.44

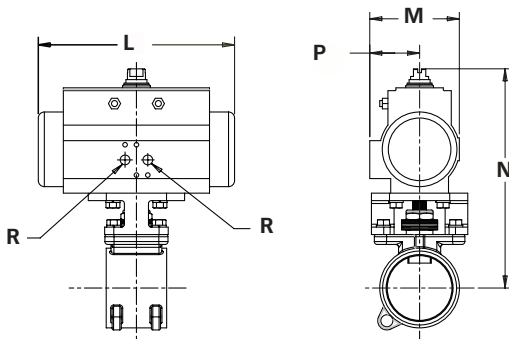

Code (#) Port Style	DIVERTER PORT • 3-way • SIDE ENTRY				DIVERTER PORT • 3-way • BOTTOM ENTRY				
	03 T-90°	04 T-90°	06 T-180°	10 L-90°	14 L-360°	15 L-180°	16 T-90°	17 TT-180°	18 LL-90°
Position A									
Position B									
Position C									
Position D									

Unit of Measure = inches
Dimensions based on actuators used with V-TEF™ seats.

ACTUATED DIMENSIONS

Size	80 PSI Double Acting					60 PSI Double Acting					80 PSI Spring Return					60 PSI Spring Return				
	L	M	N	P	R	L	M	N	P	R	L	M	N	P	R	L	M	N	P	R
1/2"	5.55	2.79	5.84	1.61	1/8	6.46	3.17	6.29	1.77	1/8	5.55	2.79	5.84	1.61	1/8	5.55	2.79	5.84	1.61	1/8
3/4"	6.46	3.17	6.44	1.77	1/8	6.46	3.17	6.44	1.77	1/8	5.55	2.79	5.99	1.61	1/8	5.55	2.79	5.99	1.61	1/8
1"	8.27	3.72	7.80	2.07	1/8	8.27	3.72	7.80	2.07	1/8	5.55	2.79	6.64	1.61	1/8	5.55	2.79	6.64	1.61	1/8
1-1/2"	10.83	4.85	10.16	2.68	1/4	10.83	4.85	10.16	2.68	1/4	6.46	3.17	8.39	1.77	1/8	8.27	3.72	9.10	2.07	1/8
2"	10.83	4.85	10.47	2.68	1/4	13.12	5.39	11.82	2.87	1/4	8.27	3.72	9.42	2.07	1/8	8.27	3.72	9.42	2.07	1/8
2-1/2"	13.12	5.39	13.48	2.87	1/4	14.65	5.83	13.96	3.15	1/4	13.12	5.39	13.48	2.87	1/4	13.12	5.39	13.48	2.87	1/4
3"	14.65	5.83	14.29	3.15	1/4	17.13	6.46	15.16	3.44	1/4	13.12	5.39	13.81	2.87	1/4	13.12	5.39	13.81	2.87	1/4
4"	17.15	6.46	17.34	3.44	1/4	17.15	6.46	17.34	3.44	1/4	19.69	7.36	18.28	4.29	1/4	19.69	7.36	18.28	4.29	1/4



<http://www.pbmvalve.com/valves/3-way-diverter-port-valve>

<http://pbmvalve.com/maintenance-instructions>



www.PBMValve.com

PBM, Inc. • 1070 Sandy Hill Road, Irwin, PA 15642

Phone: 800.967.4PBM • 724.863.0550

E-mail: info@pbmvalve.com

© Copyright 2018 PBM, Inc. PB-DD5

