

PBM FIRE RATED 2-WAY BALL VALVES

SP Series 6, 1/2" - 3"



DESIGN FEATURES:

- Fire Rated, tested to API-607
- **SP SERIES 6 FIRE RATED VALVES HAVE O-RINGS.**
- Valve shall be a three-piece "swing-out" body design
- Valves meet ASME B16.34
- Stem assembly accommodates PBM Direct Mount Actuation for accurate alignment and increased cycling life.
- Full port design
- Valves are rated to full vacuum.
- Optional Fusible Link – A Spring Return Handle unit can be equipped with optional fusible links and/or electro thermal links specified to a customer's required melt temperature, which closes the valve during fire conditions.

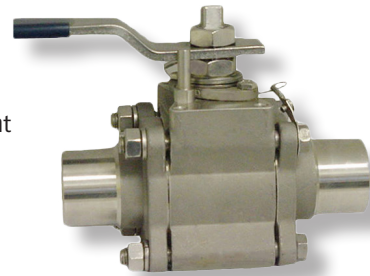

SPECIFICATIONS	Fire Rated 2-Way Valves
Sizes	1/2" - 3" Series 6
Material	316/316L, (ASTM A351 CF3M), Hastelloy® C276 and other ASME B16.34 materials
Temperatures	Up to 450° depending on seat and seal material
End Connections	Flange, NPT, Extended Butt weld for pipe, Extended Socket weld
Seats & Seals	V-TEF™ or S-TEF® Seats, Graphite seals, O-rings (FKM V1274-75/80, EPR E3609-70, Others available)
Stem Packing Material	V-TEF™ or S-TEF®, Graphite seals
Body Bolts & Nuts	18-8 Stainless Steel, Fully encapsulated
Maximum Working Pressure	up to 700 psig CWP depending on valve series, size and temperature
Finish	Standard internal finish of 125 Ra ID

CV Values (gpm)	
Size	Series 6
1/2"	12
3/4"	42*
1"	73
1-1/2"	170
2"	360
2-1/2"	650
3"	935

End Fitting Length or Diameter			
Size	J-, U-	B-D-	L-
1/2"	0.41	1.50	3.50
3/4"	0.53	1.50	3.88
1"	0.53	1.50	4.25
1-1/2"	0.53	1.50	5.00
2"	0.66	1.75	6.00
2-1/2"	0.69	2.31	7.00
3"	0.69	2.31	7.50

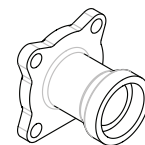
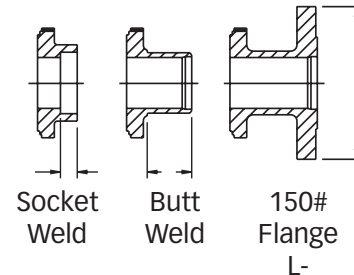

Extended Socket Weld J-

How To Order:

PRODUCT (1-2)		MATERIAL (3-4)		SIZE (5)		SERIES (6)		END CONNECTION (7-8)		SEAT & SEAL (9)		PURGE PORT BALL OPTIONS (10-11)		BALL & STEM (12)		OPERATOR (13-14)		POLISH OPTIONS (15-16)	
SP	H-	Cast 316/316L S/S	C	1/2"	6	B-	Sch. 40 Butt Weld	G	V-TEF™ Seats / Graphite Seals / FKM O-Rings	--	No Purge Port or Ball Option	-	Standard Ball and Stem	--	W/ Standard Lever Handle	-	125 Ra ID Standard		
	HL	Cast 316L S/S	D	3/4"		D-	Sch. 10 Butt Weld	J	V-TEF™ Seats / Graphite Seals / VTFE Cav Fill / FKM O-Rings	-8	Self Flushing Ball	G	17-4PH Stem	02	W/O Handle / W/ Stem Actuator Prep	A	20 Ra ID		
	E-	Carbon Steel	E	1"		J-	Extended Socket Weld	Z	V-TEF™ Seats / Graphite Seals / EPR O-Rings	-V	Slotted V-Ball			04	Locking Lever Handle	C	20 Ra ID / 32 Ra OD		
	C-	Hastelloy C-276	G	1-1/2"		L-	150# Flange			-W	30° V-Ball			18	Extended Handle (1/2" thru 3")				
			H	2"		M-	300# Flange	2	V-TEF™ Seats / Graphite Seals / VTFE Cav Fill / EPR O-Rings	-X	45° V-Ball			20	DA 80psig actuator	F	20 Ra ID after Electro Polish		
	Y-	Hastelloy C-22	J	2-1/2"		P-	Male NPT			-Y	60° V-Ball			27	DA 60psig actuator				
			K	3"		Q-	Female NPT	H	S-TEF® Seats / Graphite Seals / FKM O-Rings		Other Purge Port & Ball Options - Contact PBM.			34	SR 80psig actuator				
	P-	AL6XN				U-	Socket Weld							41	SR 60psig actuator				
								0	S-TEF® Seats / Graphite Seals / EPR O-Rings										
								9	V-TEF™ Seats / Seals / FEP Encaps. FKM O-Rings										

Other material options available - Contact PBM.

Other operator options available - Contact PBM.

Other Seat/seal options available - Contact PBM.

PBM Industrial Fire Rated 2-Way Ball Valves Manual

2-Way Valve with Locking Handle

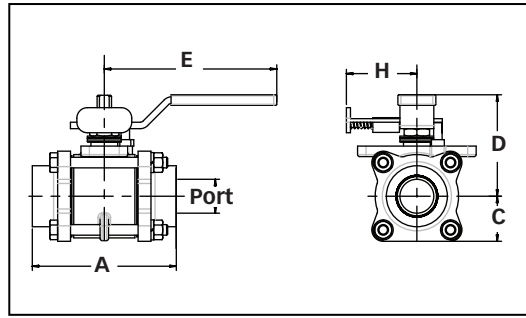

2-Way Valve with Ext. Locking Handle

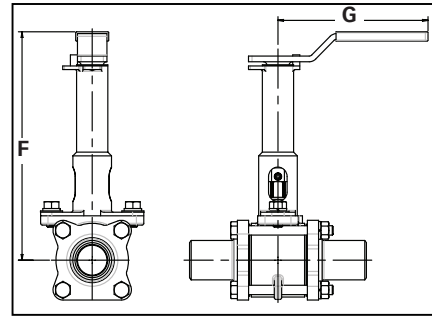

Valve Size	Size Code	Port Dia.	A				C ϕ to Bottom B- D- Q- S- T- U	D ϕ to Top of Handle	E Handle Length from ϕ	Ext. Locking Handle		Locking Handle		Approx. Weights	
			Face to Face							F	G	H	Hole Dia. for Lock	B- D- Q- U-	L-
			Q- U- S- T-	B- D-	J-	L-									
1/2"	C	0.5	3.12	5.5	6.34	5.5	0.92	2.63	4.15	7.19	5.09	1.62	.25	1.7 lbs.	4.0 lbs.
3/4"	D	0.75	3.44	5.5	6.57	5.8	1	2.78	4.15	7.34	5.09	1.62	.25	2.0 lbs.	5.2 lbs.
1"	E	1	4.25	5.99	7.05	6.5	1.33	3.03	5.09	7.62	5.09	2.08	.28	4.5 lbs.	8.7 lbs.
1-1/2"	G	1.5	5.5	7.5	8.56	8	1.78	4.1	8.68	9.45	8.00	2.58	.38	10.2 lbs.	17.4 lbs.
2"	H	2	6	8	9.26	9.8	2.15	4.41	8.68	9.76	8.00	2.58	.38	15.4 lbs.	26.5 lbs.
2-1/2"	J	2.5	8	11.5	CF	11.5	2.79	6.45	12.44	11.36	12.06	3.47	.38	36.0 lbs.	53.5 lbs.
3"	K	3	9	13.5	14.88	12.8	3.14	6.78	12.44	11.69	12.06	3.47	.38	48 lbs.	68 lbs.

ACTUATED DIMENSIONS

Unit of Measure = inches
Dimensions based on actuators used with V-TEF™ seats.

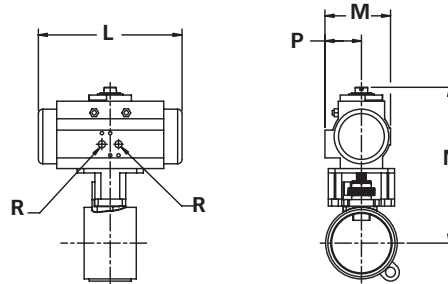

Size	80 PSI Double Acting					60 PSI Double Acting					80 PSI Spring Return					60 PSI Spring Return				
	L	M	N	P	R	L	M	N	P	R	L	M	N	P	R	L	M	N	P	R
1/2"	5.55	2.79	5.84	1.61	1/8	6.46	3.17	6.29	1.77	1/8	5.55	2.79	5.84	1.61	1/8	5.55	2.79	5.84	1.61	1/8
3/4"	6.46	3.17	6.44	1.77	1/8	6.46	3.17	6.44	1.77	1/8	5.55	2.79	5.99	1.61	1/8	5.55	2.79	5.99	1.61	1/8
1"	8.27	3.72	7.80	2.07	1/8	8.27	3.72	7.80	2.07	1/8	5.55	2.79	6.64	1.61	1/8	5.55	2.79	6.64	1.61	1/8
1-1/2"	10.83	4.85	10.16	2.68	1/4	10.83	4.85	10.16	2.68	1/4	6.46	3.17	8.39	1.77	1/8	8.27	3.72	9.10	2.07	1/8
2"	10.83	4.85	10.47	2.68	1/4	13.12	5.39	11.82	2.87	1/4	8.27	3.72	9.42	2.07	1/8	8.27	3.72	9.42	2.07	1/8
2-1/2"	13.12	5.39	13.48	2.87	1/4	14.65	5.83	13.96	3.15	1/4	13.12	5.39	13.48	2.87	1/4	13.12	5.39	13.48	2.87	1/4
3"	14.65	5.83	14.29	3.15	1/4	17.13	6.46	15.16	3.44	1/4	13.12	5.39	13.81	2.87	1/4	13.12	5.39	13.81	2.87	1/4



<http://www.pbmvalve.com/valves/fire-rated-valves>

<http://pbmvalve.com/maintenance-instructions>

www.PBMValve.com

PBM, Inc. • 1070 Sandy Hill Road, Irwin, PA 15642

Phone: 800.967.4PBM • 724.863.0550

E-mail: info@pbmvalve.com

